

# SolidWorks® 2011

## Building a Trebuchet

Project-based Approach to Learning SolidWorks

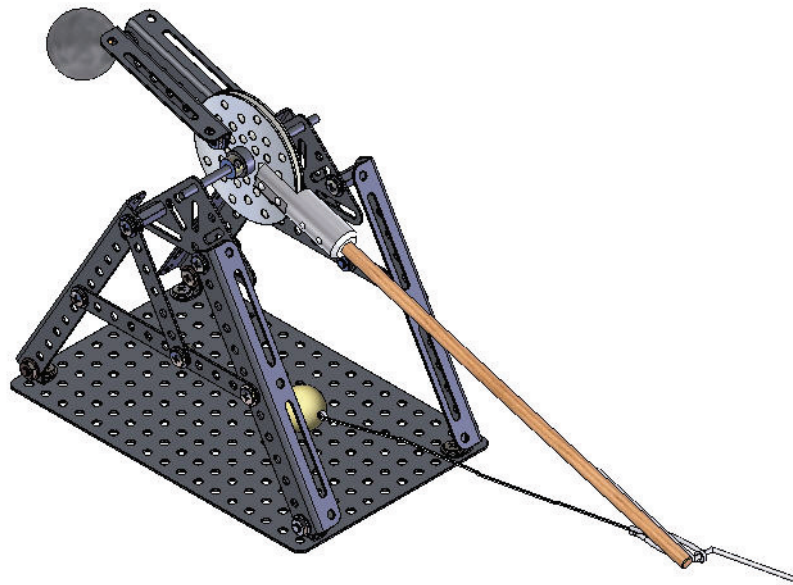

Dassault Systèmes SolidWorks Corp.  
300 Baker Avenue  
Concord, MA 01742 USA  
Phone: 1 800 693 9000

Outside the U.S.: 1 978 371 5011  
Fax: 1 978 371 7303  
Email: [info@solidworks.com](mailto:info@solidworks.com)  
Web: <http://www.solidworks.com/education>

© 1995-2011, Dassault Systèmes SolidWorks Corporation, a Dassault Systèmes S.A. company, 300 Baker Avenue Concord, Massachusetts 01742 USA. All Rights Reserved.

The information and the software discussed in this document are subject to change without notice and are not commitments by Dassault Systèmes SolidWorks Corporation (DS SolidWorks).

No material may be reproduced or transmitted in any form or by any means, electronic or mechanical, for any purpose without the express written permission of DS SolidWorks. The software discussed in this document is furnished under a license and may be used or copied only in accordance with the terms of this license. All warranties given by DS SolidWorks as to the software and documentation are set forth in the SolidWorks Corporation License and Subscription Service Agreement, and nothing stated in, or implied by, this document or its contents shall be considered or deemed a modification or amendment of such warranties.

**Patent Notices for SolidWorks Standard, Premium, and Professional Products.**

US Patents 5,815,154; 6,219,049; 6,219,055; 6,603,486; 6,611,725; and 6,844,877 and certain other foreign patents, including EP 1,116,190 and JP 3,517,643. US and foreign patents pending, e.g., EP 1,116,190 and JP 3,517,643). U.S. and foreign patents pending.

**Trademarks and Other Notices for All SolidWorks Products.**

SolidWorks, 3D PartStream.NET, 3D ContentCentral, PDMWorks, eDrawings, and the eDrawings logo are registered trademarks and FeatureManager is a jointly owned registered trademark of DS SolidWorks. SolidWorks Enterprise PDM SolidWorks Simulation, SolidWorks Flow Simulation, and SolidWorks 2010 are product names of DS SolidWorks.

CircuitWorks, Feature Palette, FloXpress, PhotoWorks, TolAnalyst, and XchangeWorks are trademarks of DS SolidWorks.

FeatureWorks is a registered trademark of Geometric Ltd. Other brand or product names are trademarks of their respective holders.

**COMMERCIAL COMPUTER SOFTWARE - PROPRIETARY.**

US Government Restricted Rights. Use, duplication, or disclosure by the government is subject to restrictions as set forth in FAR 52.227-19 (Commercial Computer Software - Restricted Rights), DFARS 227.7202 (Commercial Computer Software and Commercial Computer Software Documentation), and in the license agreement, as applicable.

Contractor/Manufacturer:

Dassault Systèmes SolidWorks Corp, 300 Baker Avenue, Concord, Massachusetts 01742 USA

**Copyright Notices for SolidWorks Standard, Premium, and Professional Products.**

Portions of this software © 1990-2011 Siemens Product Lifecycle Management Software III (GB) Ltd.

Portions of this software © 1998-2011 Geometric Ltd.

Portions of this software © 1986-2011 mental images GmbH & Co.KG.

Portions of this software © 1996-2011 Microsoft Corporation. All Rights Reserved.

Portions of this software © 2000-2011 Tech Soft 3D

Portions of this software © 1998-2008 3Dconnexion.

This software is based in part on the work of the Independent JPEG Group. All Rights Reserved.

Portions of this software incorporate PhyX™ by NVIDIA 2006-2009.

Portions of this software are copyrighted by and are the property of UGS Corp. © 2011.

Portions of this software © 2001 - 2011 Luxology, Inc. All Rights Reserved, Patents Pending.

Portions of this software © 2007 - 2011 DriveWorks Ltd.

Copyright 1984 - 2010 Adobe Systems, Inc. and its licensors. All rights reserved. Protected by U.S. Patents 5,929,866; 5,943,063; 6,289,364; 6,639,593; 6,743,382; Patents Pending. Adobe, the Adobe logo, Acrobat, the Adobe PDF logo, Distiller and Reader are registered trademarks or trademarks of Adobe Systems Inc. in the U.S. and other countries.

For more copyright information, in SolidWorks see **Help, About SolidWorks**.

Other portions of SolidWorks 2011 are licensed from DS SolidWorks licensors.

**Copyright Notices for SolidWorks Simulation.**

Portions of this software © 2008 Solversoft Corporation. PCGLSS © 1992 - 2007 Computational Applications and System Integration, Inc. All Rights Reserved.

Portions of this product are distributed under license from DC Micro Development, Copyright © 1994 - 2005 DC Micro Development. All Rights Reserved.

## Table of Contents

<b>Lesson 1: Introduction .....</b>	<b>1</b>
Using The Book .....	2
What is SolidWorks Software .....	2
Prerequisites.....	2
Parts, Assemblies, and Drawings.....	3
Parts.....	3
Assemblies .....	3
Drawings .....	3
Relationship of Parts, Assemblies, and Drawings .....	4
Fully Associative.....	5
User Interface.....	5
Menu Bar Toolbar.....	5
Menu Bar Menu .....	6
Drop-down / Pop-up Context Toolbar .....	6
Keyboard Shortcuts.....	7
CommandManager Tabs .....	8
FeatureManager Design Tree.....	9
Heads-up View Toolbar .....	9
Task Pane .....	10
Mouse Buttons .....	10
Consolidated Toolbars .....	11
System Feedback.....	11
Getting Help.....	11
Before You Begin.....	13
<b>Lesson 2: Modeling the Trebuchet.....</b>	<b>17</b>
Sketching .....	18
Sketch Entities .....	18

Sketch Tools .....	19
Sketch Planes .....	19
Starting a SolidWorks session .....	19
New SolidWorks Document Modes .....	23
Creating a New Part .....	23
Setting System Options .....	24
Preparing to Sketch .....	27
Dimensioning the Sketch .....	28
Inserting an Extruded Base Feature .....	31
Saving the Axle Part .....	32
Modifying the Dimension of the Axle .....	34
Applying Material to the Axle .....	35
Inserting a Chamfer Feature .....	36
PhotoView 360 .....	39
Creating a Photorealistic Image .....	39
Creating the Shaft Collar Part .....	42
Inserting an Extruded Base Feature .....	46
Inserting a new Sketch .....	47
Adding a Dimension .....	47
Inserting an Extruded Cut Feature .....	48
Inserting a Chamfer Feature .....	49
Applying Material to the Shaft Collar .....	50
Exploring the DisplayManager Tab and Applying Appearance .....	52
Creating the 7 Hole Flatbar Part .....	55
Adding Dimensions .....	59
Inserting an Extruded Base Feature .....	60
Inserting an Extruded Cut Feature .....	61
Adding a Dimension .....	62
Inserting an Extruded Cut .....	63
Inserting a Linear Pattern feature .....	64
Inserting a Fillet .....	67
Applying Material to the 7 Hole Flatbar .....	69
Creating the Ball Weight .....	70
Applying Material to the Ball Weight .....	78
<b>Lesson 3: Assembling the Trebuchet .....</b>	<b>83</b>
Renaming a Part .....	84
Creating an Assembly .....	85
Standard, Advanced and Mechanical Mates .....	90
Inserting Mates .....	91
Creating the Counter Weight Assembly .....	97
Inserting Mates .....	101

## SolidWorks

Using SolidWorks Toolbox .....	104
Inserting the Weight-Hook Assembly .....	110
Inserting Mates .....	111
Inserting the Second Washer .....	116
Inserting a Hex Nut.....	118
Creating the Trebuchet Assembly .....	121
<b>Lesson 4: Analyzing the Trebuchet .....</b>	<b>135</b>
Stress Analysis of the 7 Hole Flatbar Part.....	136
Design Analysis .....	136
Stress Analysis.....	136
SolidWorks SimulationXpress Wizard User Interface .....	137
Analyze the 7 Hole Flatbar Part.....	138
Opening the 7 Hole Flatbar Part .....	138
Running SolidWorks SimulationXpress and Setting Analysis Options .....	141
Running SimulationXpress and Setting Analysis Options.....	142
Applying a Fixture .....	143
Applying a Load .....	144
Applying a Load.....	145
Assigning Material.....	148
Assigning Material .....	149
Running the Analysis.....	150
Running the Analysis .....	151
Viewing Results.....	152
Viewing the Results .....	153
Running a Report.....	156
Optimizing the Model.....	157
Optimizing the Model.....	158
Saving Analysis Data and Closing SimulationXpress.....	160
SolidWorks Motion .....	161
Starting a SolidWorks Motion session .....	162
Conclusion .....	164
<b>Lesson 5: Creating a Trebuchet Drawing .....</b>	<b>165</b>
Drawings.....	166
Creating a Drawing – General Procedure .....	166
Opening the 7 Hole Flatbar Part .....	166
Creating a Part Drawing .....	167
Inserting an Isometric View using the View Palette .....	173
Saving the Drawing .....	174
Drawing View Display .....	174
Drawing Modes .....	175

Moving Drawing Views .....	177
Detailing a Drawing.....	178
Dimensions .....	178
Dimension Guidelines – Appearance .....	178
Inserting Dimensions .....	178
Associativity .....	186
Adding a Dimension .....	189
Modifying the Radius Text.....	190
Creating a Design Tables.....	191
Adding a Sheet to a Drawing.....	196
Sharing Information and Viewing eDrawings Files .....	202
eDrawings™ .....	202
Viewing eDrawings .....	202
Creating and Viewing an eDrawings File.....	203
Saving eDrawings Files .....	204
Saving an eDrawings File.....	204
Returning to the 7 Hole Flatbar drawing .....	205
Creating an Assembly Drawing.....	205
Exploded Views.....	211
Inserting an Exploded View .....	211
Inserting a Bill of Materials.....	219
Adding a Part Number in the Bill of Materials.....	220
Adding a Bill of Materials Description .....	222
Inserting Balloons.....	225
Creating an Trebuchet Assembly Drawing.....	226
Inserting a Bill of Materials.....	230
Inserting the String and Ball Assembly .....	232
<b>Glossary .....</b>	<b>241</b>

# **Lesson 1**

## **Introduction**

When you complete this lesson, you will be able to:

- Identify the principal components of the SolidWorks 2011 Windows® graphical User Interface, Menus, Toolbars, and Task Pane.
- Identify the function of each mouse button when using SolidWorks.
- Understand the difference between a part, assembly, and a drawing.
- Describe the relationship between parts, assemblies, and drawings.
- Utilize the SolidWorks keyboard shortcut keys.
- Use the SolidWorks Tutorials.
- Use SolidWorks Help.
- Download the required model files.

## Using The Book

The book provides you the knowledge to use the SolidWorks 2011 software. Before long, you will be navigating through SolidWorks and experiencing many of the software's major capabilities. You will be creating parts, assemblies, and drawings throughout the book. You will learn by doing!

## What is SolidWorks Software

SolidWorks is a design automation software package. In SolidWorks, you sketch 2D ideas and experiment with different designs to create 3D models. SolidWorks uses an easy to learn Windows® graphical user interface.

SolidWorks is used by students, designers, engineers, and other professionals to produce single and complex parts, assemblies, and drawings.

## Prerequisites

It is recommended that you complete the following SolidWorks Tutorials that are integrated in the software before starting the Trebuchet project:

- Lesson 1 - Parts.
- Lesson 2 - Assemblies.
- Lesson 3 - Drawings.

Access the SolidWorks Tutorial by clicking **Help, SolidWorks Tutorials** from the Menu bar menu.

Click **Getting Started** from the Tutorials by Category dialog box.

**Note:** Click **Help, Student Curriculum** to access the Trebuchet folder curriculum. Click **Help, Instructors Curriculum** to access the Educator Resources.

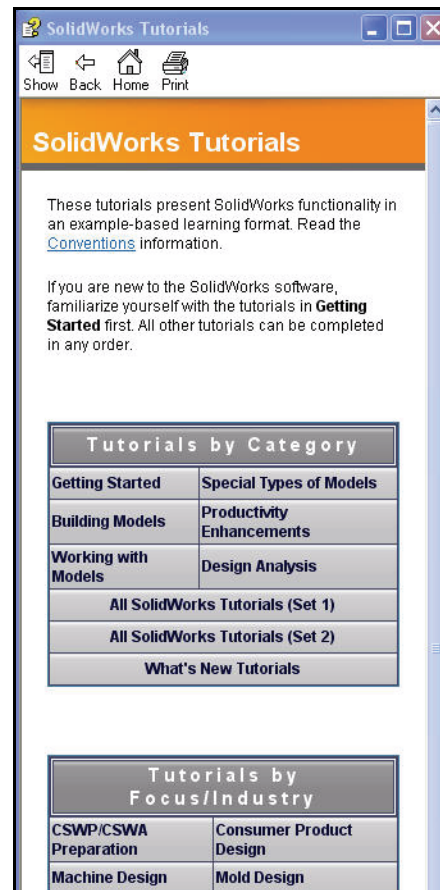

## Designing the Trebuchet Assembly

In this book, you will learn how to design a Trebuchet using SolidWorks. You will create parts, assemblies, and drawings for the Trebuchet assembly. You will also perform analysis on various components in the Trebuchet assembly.

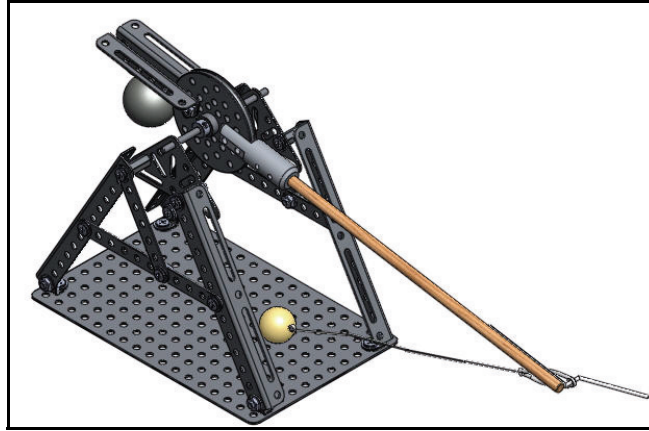

## Parts, Assemblies, and Drawings

### Parts

Parts are single three dimensional (3D) objects. Parts are the basic building blocks for 3D modeling. Parts are used as components in assemblies and are represented in drawings.

### Assemblies

Assemblies are logical collections of components. Components can be parts or other assemblies. All of the parts are combined into a single assembly according to the way they are designed to function. The relationships of the parts can be captured so that you can communicate your design intent. The design intent governs how the part is built and how it will react to modifications.

When parts are manufactured, the assembly shows how these parts should be put together, or assembled.

An assembly within an assembly is called a sub-assembly. Particularly in large projects, different sub-assemblies will be designed by different people; even different companies.

### Drawings

Drawings are 2D representations of 3D parts or assemblies. Drawings are required for manufacturing, quality assurance, supply chain management, and other functions.



## Fully Associative

Parts, assemblies, and drawings are associative. This means that changes made in one area are automatically reflected in all the associated areas affected by that change. For example, changes that you make to an assembly are reflected in the drawings and parts of that assembly.

Likewise, changes that you make to a part are reflected in the drawings and assembly.









Typically, you design each part, combine the parts into assemblies, and generate drawings in order to manufacture the parts and assemblies.

## User Interface

The first thing that you notice about the SolidWorks user interface is that it looks like Windows®. That is because it is Windows!

SolidWorks 2011 has had user interface enhancement along with additional tutorials, features, and tools. The SolidWorks 2011 (UI) is designed to make maximum use of the Graphics area space for your model. Displayed toolbars and commands are kept to a minimum.

## Menu Bar Toolbar

The Menu Bar toolbar contains a set of the most frequently used tool buttons from the Standard toolbar. The available tools are: **New**  - Creates a new document, **Open**  - Opens an existing document, **Save**  - Saves an active document, **Print**  - Prints an active document, **Undo**  - Reverses the last action, **Select**  - Select entities in the graphics area or the FeatureManager design tree with the pointer. **Rebuild**  - Rebuilds the active part, assembly or drawing, **File Properties**  - Shows the summary information of the active document, **Options**  - Changes system options, document properties, and Add-Ins for SolidWorks.



## Menu Bar Menu

Click SolidWorks in the Menu Bar toolbar to display the default Menu Bar menu. SolidWorks provides a context-sensitive menu structure. The menu titles remain the same for all three types of documents; part, assembly, and drawing but the menu items change depending on which type of document is active. The display of the menu is also dependent on the work flow customization that you have selected.

The default menu items for an active document are: **File, Edit, View, Insert, Tools, Window, Help, and Pin.**

**Note:** The Pin  tool displays both the Menu Bar toolbar and the Menu Bar menu.

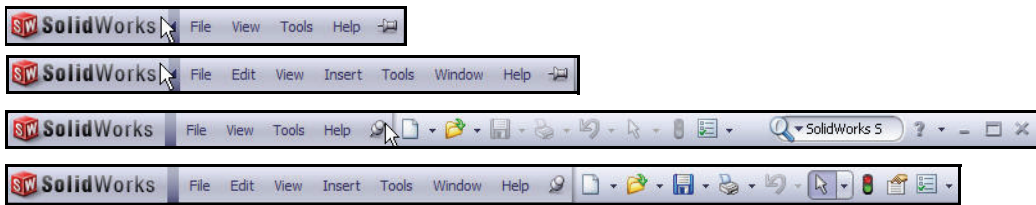

## Drop-down / Pop-up Context Toolbar

Communicate with SolidWorks either through the Drop-down menu or the Pop-up Context toolbar. The Drop-down menu from the Menu Bar toolbar or the Menu Bar menu provides access to various commands.

When you select, (Click or Right-click) items in the Graphics area or FeatureManager, a Pop-up Context toolbar is displayed and provides access to frequently performed actions for that context.

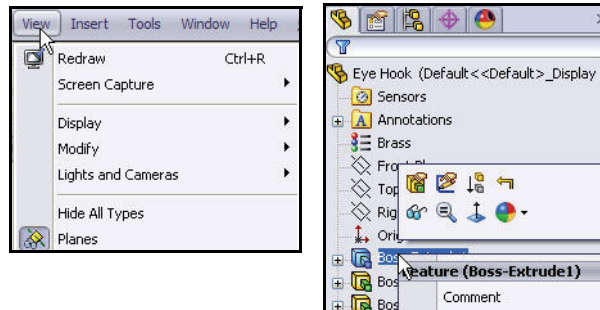

## SolidWorks

**Note:** Context toolbars are available for the most commonly used selections.

### Keyboard Shortcuts

Some menu items indicate a keyboard shortcut like this: . SolidWorks conforms to standard Windows conventions for shortcuts such as **Ctrl+O** for **File, Open**; **Ctrl+S** for **File, Save**; **Ctrl+Z** for **Edit, Undo**, and so on. In addition, you can customize SolidWorks by creating your own shortcuts.

## Introduction

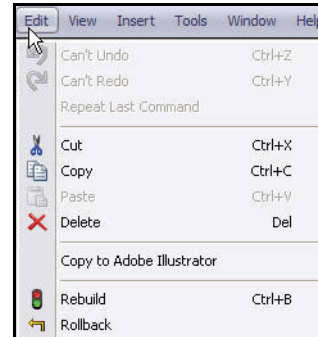

## CommandManager Tabs

The CommandManager is a context-sensitive toolbar that automatically updates based on the toolbar you want to access. By default, it has toolbars embedded in it based on your active document type. When you click a tab below the CommandManager, it updates to display that toolbar. Example, if you click the Sketch tab, the Sketch toolbar is displayed. The default tabs for a part document are: **Features**, **Sketch**, **Evaluate**, **DimXpert**, and **Office Products**.

Below is an illustrated CommandManager for a default part document and PhotoWorks Add-In.

**Note:** If you have SolidWorks Premium or SolidWorks Professional, the Office Products tab is displayed on the CommandManager.

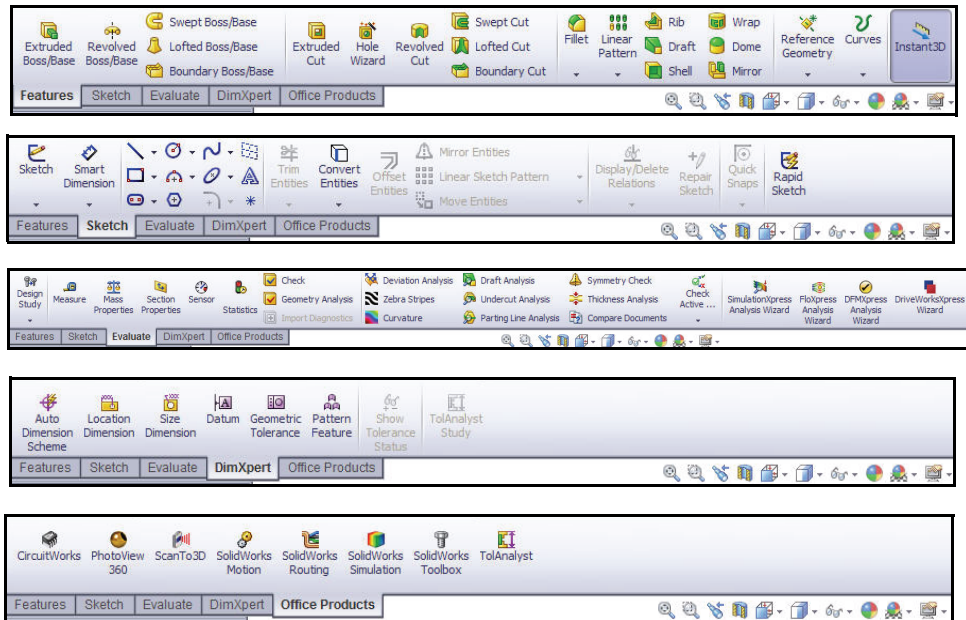





## FeatureManager Design Tree

The FeatureManager® design tree is a unique part of the SolidWorks software that employs patented SolidWorks technology to visually display all of the features in a part, assembly, or drawing.

As features are created, they are added to the FeatureManager. As a result, the FeatureManager represents the chronological sequence of modeling operations. The FeatureManager also allows access to editing the features and objects that it contains.

The Part FeatureManager consist of five default tabs:

**FeatureManager** , **PropertyManager** ,  
**ConfigurationManager** , **DimXpertManager**   
 and the **DisplayManager** .

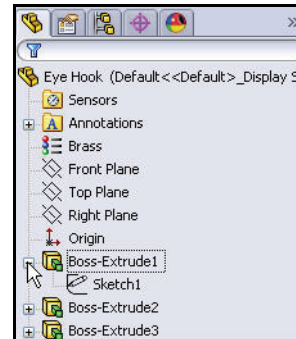





## Heads-up View Toolbar





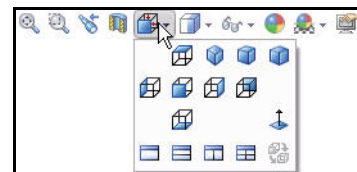
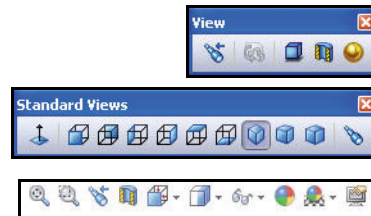

SolidWorks provides the user with numerous view options from the Standard Views, View, and Heads-up View toolbar.

The Heads-up View toolbar is a transparent toolbar that is displayed in the Graphics area when a document is active

The following views are available:





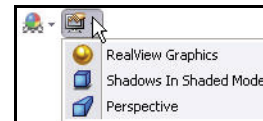
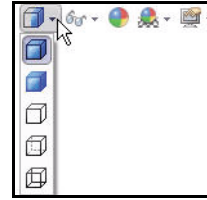

- **Zoom to Fit** : Zooms the model to fit the Graphics area.
- **Zoom to Area** : Zooms to the area you select with a bounding box.
- **Previous View** : Displays the previous view.
- **Section View** : Displays the cutaway of a part or assembly using one or more selected cross section planes.
- **View Orientation** : Selects a view orientation or the number of viewports from the drop-down menu.



- **Display Style** : Selects the style for the active view from the drop-down menu.
- **Hide/Show Items** : Selects items to hide or show in the Graphics area.
- **Edit Appearance** : Removes appearances and edit the color or mapping properties of appearances.
- **Apply Scene** : Applies a scene to an active part or assembly document.
- **View Setting** : Selects the following setting from the drop-down menu: *RealView Graphics*, *Shadows in Shaded Mode*, and *Perspective*.
- **Rotate view** : Rotates a drawing view. Is only available for a drawing.
- **3D Drawing View** : Dynamically manipulates the drawing view to make a selection. Is only available for a drawing.



## Task Pane

The Task Pane is displayed when a SolidWorks session starts. The Task Pane contains the following default tabs: **SolidWorks Resources** , **Design Library** , **File Explorer** , **View Palette** , **Appearances, Scenes, and Decals**  and **Custom Properties** .



**Note:** The Document Recover tab is only displayed in the Task Pane if your systems terminates unexpectedly with an active document and if auto-recovery is enabled in Systems Options.

## Mouse Buttons

The left, middle, and right mouse buttons have specific uses in SolidWorks.

- Left - Selects objects such as geometry, menu buttons, and objects in the FeatureManager design tree.

- Middle - Holding the middle mouse button as you drag the mouse rotates the view. Holding the Shift key down while you use the middle mouse button zooms the view. Using the Ctrl key scrolls or pans the view.
- Right - Activates context-sensitive pop-up menus. The contents of the menu differ depending on what object the cursor is over. These right-mouse button menus give you shortcuts to frequently used commands.

### Consolidated Toolbars

Similar commands are grouped into consolidated flyout buttons on the toolbar and in the CommandManager.

Example: Variations of the Rectangle  tool are consolidated together into a single button with a drop-down arrow.

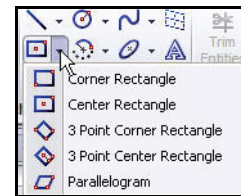

### System Feedback

System feedback is provided by a symbol attached to the cursor arrow indicating what you are selecting or what the system is expecting you to select. As the mouse cursor floats across the model, feedback comes in the form of symbols riding next to the cursor arrow. An edge is illustrated.

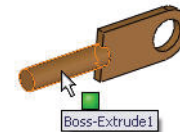
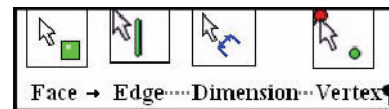



### Getting Help

SolidWorks has a comprehensive help function that is designed to assist you. The SolidWorks help screen is displayed in its own window. Click

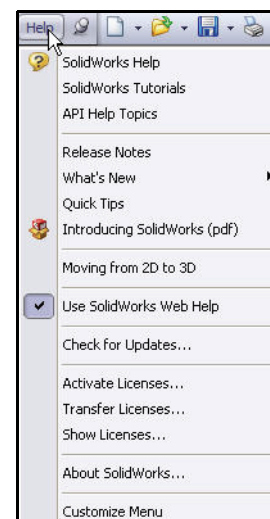
**Help, SolidWorks Help**  tool from the Menu bar toolbar to view the comprehensive SolidWorks help screen. Use SolidWorks Web Help to connect to the internet.

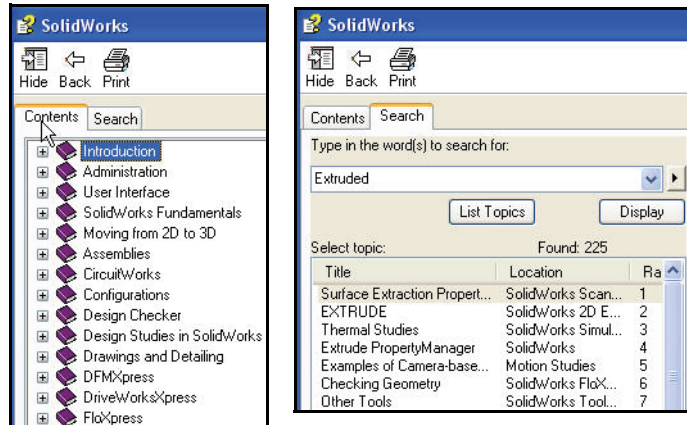



**Note:** You can also directly access help for a specific command by clicking the **Help**  icon in a PropertyManager.

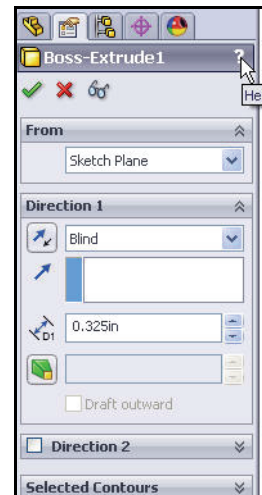

## Before You Begin

Copy the **Trebuchet Design Project** folder from the SolidWorks web site onto your computer before you start this project.

### 1 Start a SolidWorks session.

Click **All Programs, SolidWorks, SolidWorks** from the Windows Start menu. The SolidWorks application is displayed.

**Note:** If you created the SolidWorks icon on your desktop, click the icon to start a SolidWorks session.



### 2 Copy the Trebuchet Design Project folder.

Click **Help** from the Main menu bar.

Click **Student Curriculum**.

**Note:** There is a resource area for all Instructors.

Click the **Design Library**  tab from the Task Pane.

Expand the **SolidWorks Content** folder.

Expand the **SolidWorks Educator Curriculum** folder.

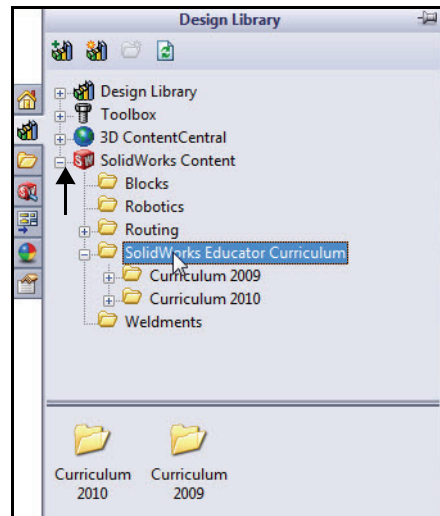
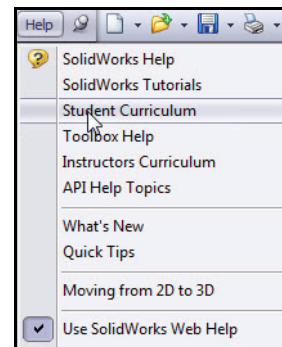

## Introduction

Double-click the needed **Curriculum** folder. View the available resources.

**Note:** At the time of writing, the **Curriculum 2011** folder was not available.

Double-click the **Trebuchet Design Project** folder.

## SolidWorks

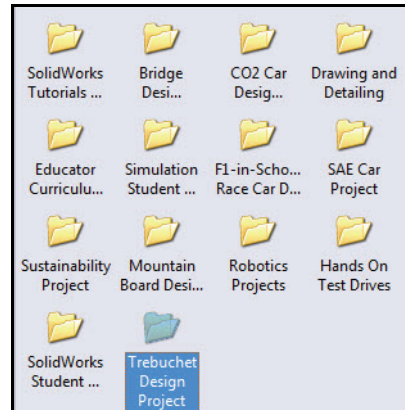
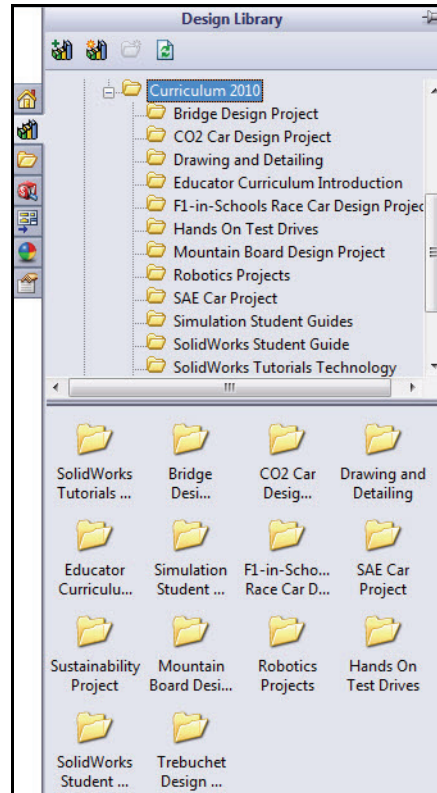

Ctrl-click the **Trebuchet Design Project** folder as illustrated to download the text and SolidWorks model files (Initial and Final).

Ask your teacher where you should save the zip file. Remember where you saved the downloaded zip file.

### 3 Located the zip folder.

Select a **folder** location on your hard drive.

Click **OK** from the Browse For Folder dialog box.

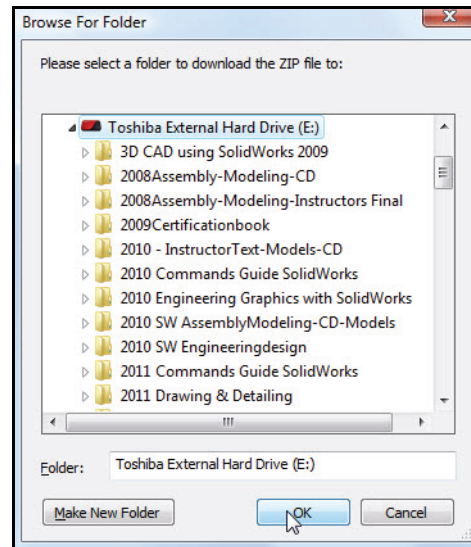
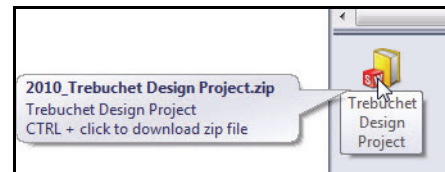

### 4 Un-zip the Folder.

**Browse** to the location where you saved the downloaded zip folder.

**Unzip** the folder. This may take a few minutes

**Extract All** files and folders.

Select the **folder** location.

Click **Extract**.

**Note:** The procedure maybe different depending on your Operating System

**Note:** At the time of writing, the **Curriculum 2011** folder was not available.

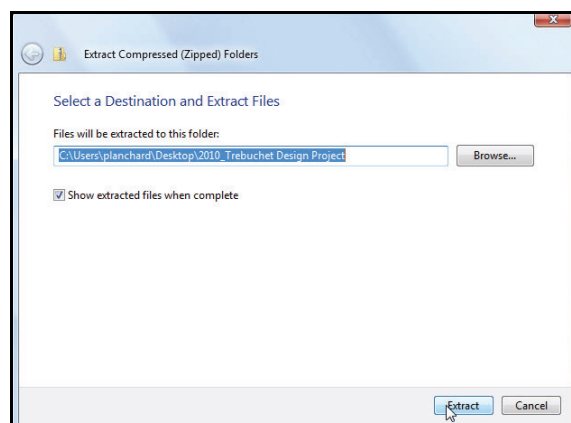
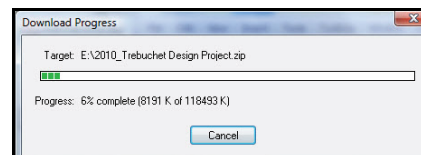

Double-click the **Project Workbook** folder to select language.

Double-click the zip **Trebuchet\_Design\_Project\_2011\_SW\_Files** folder to obtain the initial and final model files for the book.

Name	Date modified	Type	Size
Project Workbook	11/8/2010 9:18 AM	File Folder	
Trebuchet_Design_Proj...	4/29/2010 12:25 PM	Compressed (zipp...	84,754 KB

Name	Date modified	Type	Size
Trebuchet Project_2010_LR_ENG	4/27/2010 3:00 PM	Adobe Acrobat D...	26,502 KB
Trebuchet Project_2010_LR_FRA	4/27/2010 3:01 PM	Adobe Acrobat D...	13,562 KB

Name	Date modified	Type
Project Workbook	11/8/2010 9:18 AM	File Folder
Trebuchet_Design_Project_2010_SW_Files	4/29/2010 12:25 PM	Compressed (zipp...

Name	Type
SolidWorks-Treuchet-Final-Models-2010	File Folder
SolidWorks-Treuchet-Initial-Models-2010	File Folder

## Lesson 2

# Modeling the Trebuchet

When you complete this lesson, you will be able to:

- Create a 2D sketch.
- Utilize the following sketch tools: Line, Circle, Centerpoint Straight Slot, Center Rectangle, Centerline, Tangent Arc, and Trim Entities.
- Add and modify dimensions in a sketch.
- Add the following geometric relations to a sketch: Equal.
- Utilize the following features: Extruded Boss/Base, Extruded Cut, Revolved Boss/Base, Fillet, and Chamfer.
- Create a part.
- Save a part.
- Modify a part.
- Apply PhotoWorks to a part.
- Apply material to a part.
- Rename a feature in the Part FeatureManager.

## Create the Axle for the Trebuchet Counter Weight Assembly

The first part that you will build is the Axle for the Counter Weight assembly. First, you will need to open a new SolidWorks document. As you learned earlier, SolidWorks uses three kinds of documents: Parts, Assemblies, and Drawings. The Axle is a part. Open a part document.

Use the default part template that is provided with SolidWorks.

A template forms the basis of a new part document, controlling units, grid, text, and other settings for the model.

Templates allow you to define your own parameters. You can create customized templates. Save time by defining parameters once, then use them to create new documents. You can also create multiple templates for each document type.

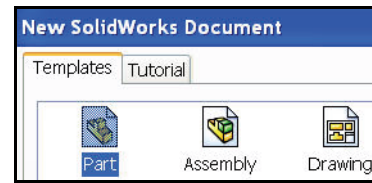
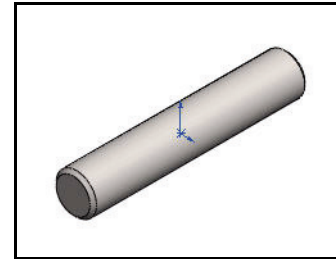

## Sketching

Solid models are built from features. Features are the building blocks of the part. Features are based on 2D sketches. Sketches provide the foundation for your SolidWorks project. Sketches are collections of 2D geometry that are used to create solid features.

Typical 2D geometry types are lines, circles, rectangles, and arcs. Sketching in SolidWorks is dynamic, with cursor feedback. Every sketch has several characteristics that contribute to its shape, size, and orientation.

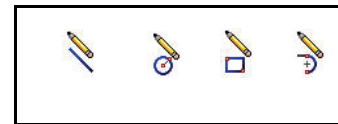

## Sketch Entities

SolidWorks offers a rich variety of sketch tools for creating profile sketches. For the Axle, you will create a sketch using the Circle Sketch  tool as illustrated.

**Note:** The Grid is deactivated in the SolidWorks Graphics window for clearer screen shots in this book. Click **Options, Document Properties** tab from the Menu bar menu. Click **Grid/Snap**. Un-check **Display grid**.

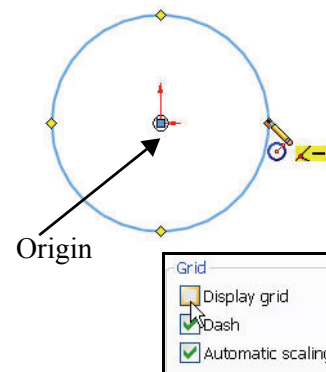

## Sketch Tools

Tools can be used to modify the sketch geometry that has been created. This often involves the trimming or extension of entities. You will use the Trim Entities  tool in this lesson.

## Sketch Planes

Sketches are flat, or planar. A plane is required for a sketch. A SolidWorks part contains three default sketch planes. They are: Front, Top, and Right.

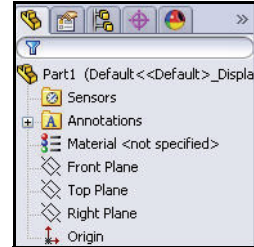

## Starting a SolidWorks session



### 1 Start the SolidWorks session.

- Click **All Programs, SolidWorks 2011, SolidWorks 2011** from the Windows Start menu.



**Tip:** Start a SolidWorks session, if available by double-clicking the left mouse button on the SolidWorks desktop shortcut icon.

### 2 Read the Tip of the Day dialog box.



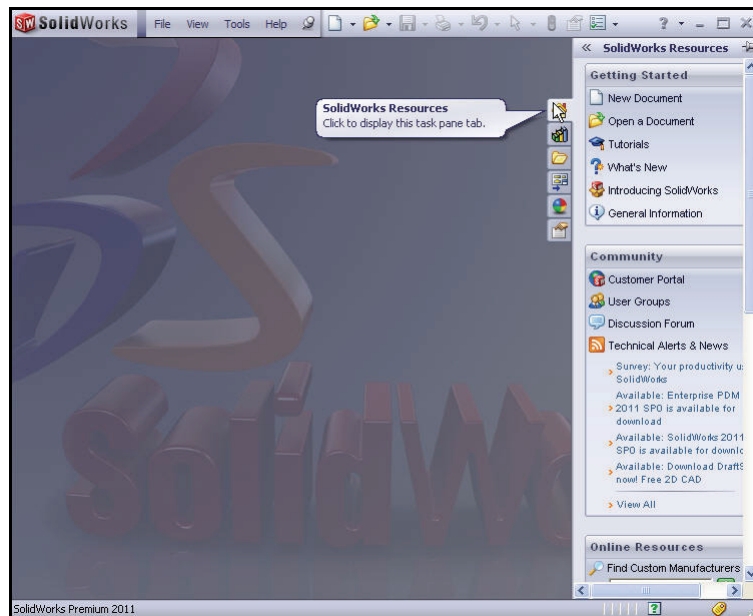



- Click the **SolidWorks Resources**  tab on the right side of the Graphics window if you do not see this screen. The Pin  tool displays both the Menu Bar toolbar and the Menu Bar menu.



## Modeling the Trebuchet

## SolidWorks

The SolidWorks 2011 default Task Pane contains six tabs:

- SolidWorks Resources  tab.
- Design Library  tab.
- File Explorer  tab.
- View Palette  tab.
- Appearances, Scenes, and Decals  tab.
- Custom Properties  tab.

The SolidWorks Resources  contains the following default menus:

- Getting Started.
- Community.
- Online Resources.

Along with the Tip of the Day box.

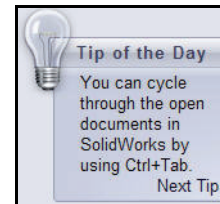

**Tip:** Other user interfaces are available to be displayed: Machine Design, Mold Design, or Consumer Products Design during the initial software installation selection.

The Design Library  tab in the Task Pane provides a central location for reusable elements such as parts, assemblies and sketches. The Design Library includes the following menus:

- Design Library.
- Toolbox.
- 3D ContentCentral.
- SolidWorks Content.

The Design Library menu contains the following folders: annotations, assemblies, features, forming tools, motion, parts, routing, and smart components.

**Note:** The SolidWorks Content folder contains the SolidWorks Educator Curriculum.

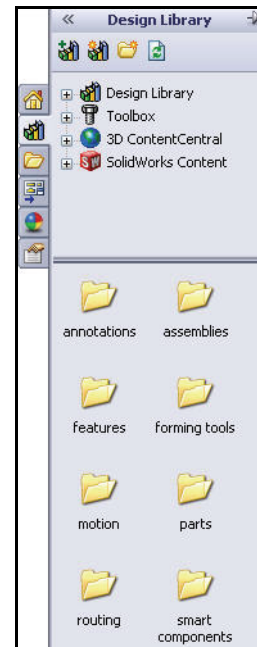

## SolidWorks

SolidWorks File Explorer  duplicates Windows Explorer in functionality on your computer, plus recent documents that are active in SolidWorks.

The View Palette  tab provides the ability to insert drawing views. It contains images of standard views, annotation views, section views, and flat patterns (sheet metal parts) of the selected model. You can drag views onto the drawing sheet to create a drawing view.

## Modeling the Trebuchet



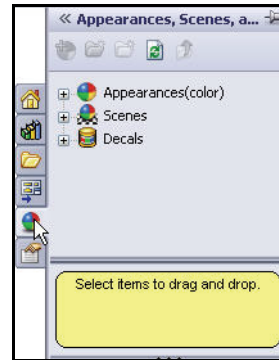

The Appearances, Scenes, and Decals  tab provides a library of appearances, scenes, and decals to apply to a model or assembly document.

**Tip:** An appearance defines the visual properties of a model, including color and texture. Appearances do not affect physical properties, which are defined by materials.

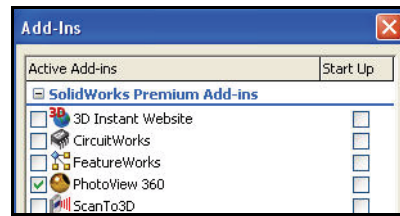
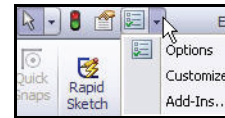

**Note:** Click **Add-Ins** from the Menu bar menu drop-down arrow. Click **PhotoView 360** from the Active Add-ins dialog box to activate the PhotoView 360 feature.



Use Custom Properties  in the Task Pane to view and enter custom and configuration-specific properties into SolidWorks files.

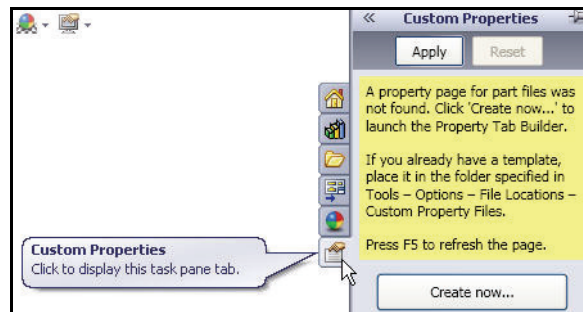

## New SolidWorks Document Modes

There are two modes in the New SolidWorks Document dialog box: **Novice** and **Advanced**. The **Novice** option is the default option with three templates. The **Advanced** option contains access to additional templates. In this book, you will use the **Advanced** option.

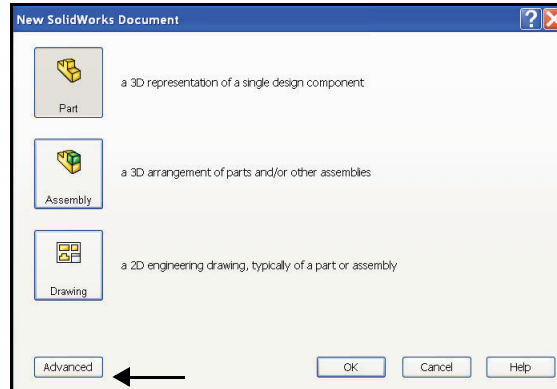

## Creating a New Part

- 1 **Create a new part.**
  - Click **New**  from the Menu bar toolbar.
- 2 **Select the Advanced mode.**
  - Click the **Advanced** button to display the New SolidWorks Document dialog box in Advanced mode.

The **Templates** tab is the default tab. **Part** is the default template from the New SolidWorks Document box.

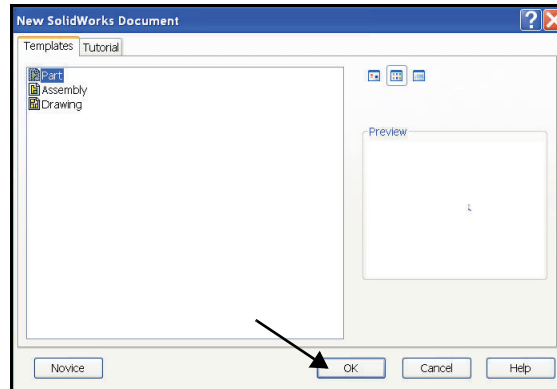

- Click **OK** from the New SolidWorks Document dialog box. A new part document window is displayed.

The **Advanced** mode remains selected for all new documents in the current SolidWorks session. When you exit SolidWorks, the **Advanced** mode setting is saved.

The default SolidWorks installation contains two tabs in the New SolidWorks Document dialog box: **Templates** and **Tutorial**. The **Templates** tab corresponds to the default SolidWorks templates. The **Tutorial** tab corresponds to the templates utilized in the SolidWorks Tutorials.

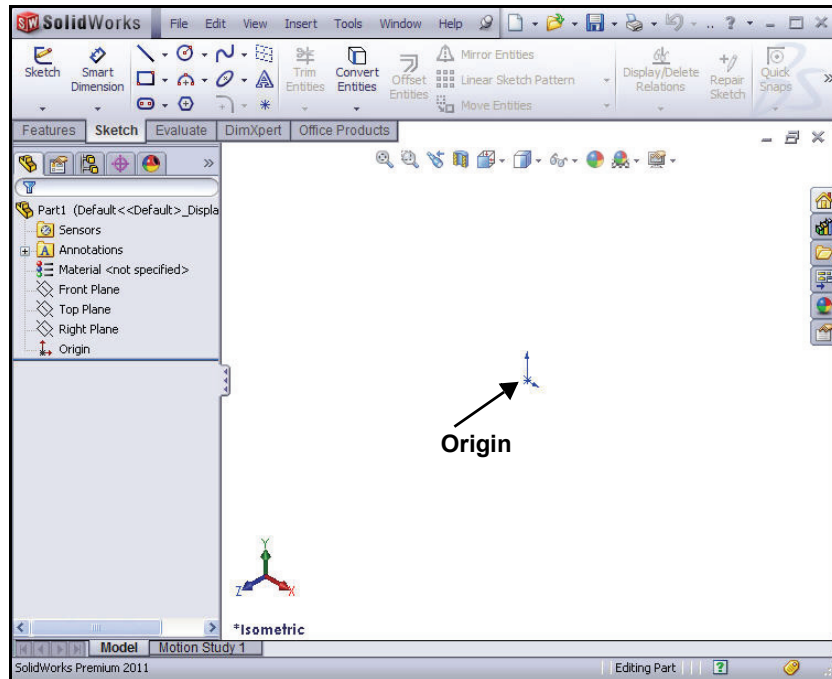

The Reference Triad, (lower left corner) displays the orientation of the model coordinate axes; (red-X, green-Y, and blue-Z) at all times. It can help show how the view orientation has been changed relative to the Front Plane.

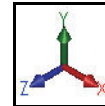

The Origin symbol represents the part's model origin which is the intersection of the X, Y, and Z axes. The Origin symbol is displayed in the color red when you are in the Sketch mode.



### Setting System Options

System Options are stored in the registry of the computer. System Options are not part of the document. Changes to the Systems Options affect the current and future documents. Review and modify the System Options. If you work on a local drive C:\, the System Options are stored on your computer.

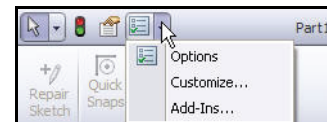

#### 1 Set Drafting Standard.

- Click **Options**  **Document Properties** tab from the Menu bar toolbar. The Document Properties - Drafting Standard dialog box is displayed.

- Select **ANSI** from the drop-down menu for Overall drafting standard.

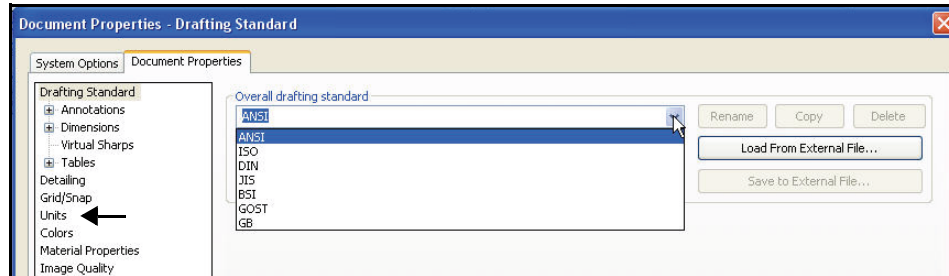

## 2 Set unit system and length.

- Click **Units**.
- Click **IPS** (inch, pound, second) for Unit system.
- Select **.123** for Length unit decimal place.
- Select **None** for Angle decimal place.
- Select **millimeters** for Dual Dimension Length.

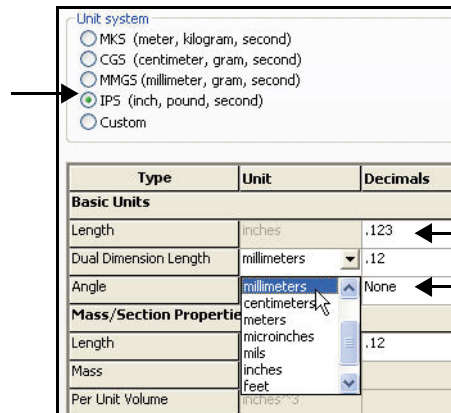

**3 Set dual unit display.**

- Click **Dimensions** from the Document Properties dialog box.
- Check the **Dual dimensions display** box.

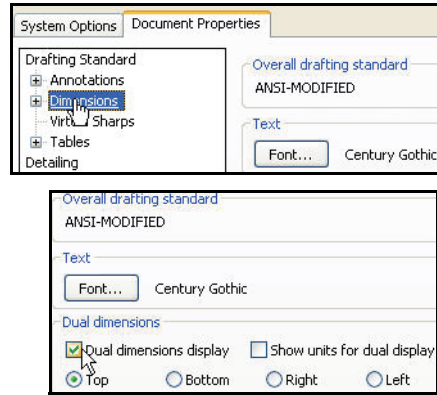

**4 Set System options.**

- Click **OK** from the Document Properties- Dimensions dialog box.

**Note:** All dimensions are displayed in IPS and MMGS units. IPS is the primary unit. Millimeters are displayed in brackets, [ ].

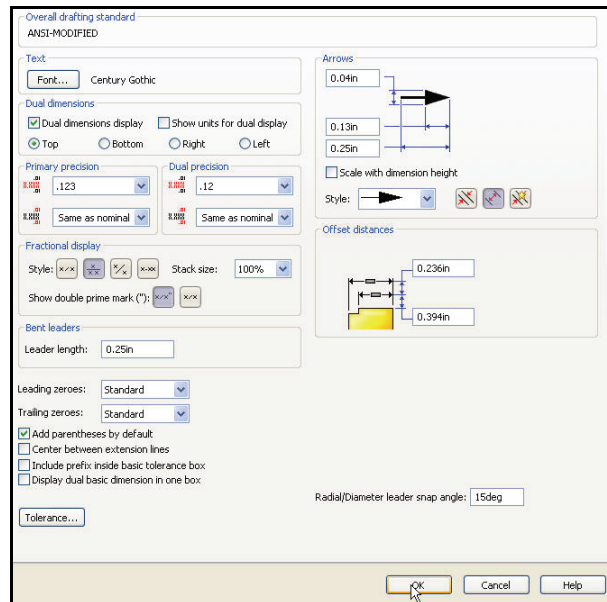

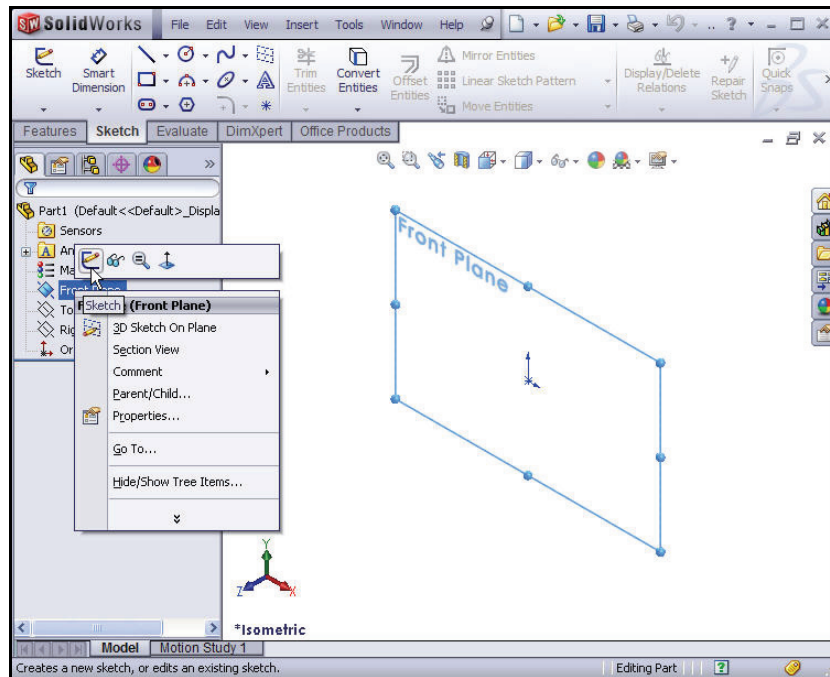

## Preparing to Sketch

- 1 **Select the Sketch plane.**
  - Right-click **Front Plane** from the FeatureManager design tree. Front Plane is highlighted in the FeatureManager.

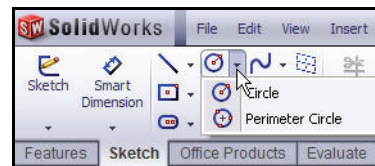

- 2 **Open a Sketch.**
  - Click **Sketch**  from the Context toolbar. The Sketch toolbar is displayed.



- 3 **Sketch a circle with a center point at the Origin.**
  - Click the **Circle**  Sketch tool. The Circle PropertyManager is displayed.
  - Move the **mouse pointer** into the Graphics window. The cursor displays the Circle Sketch tool  icon.

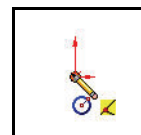

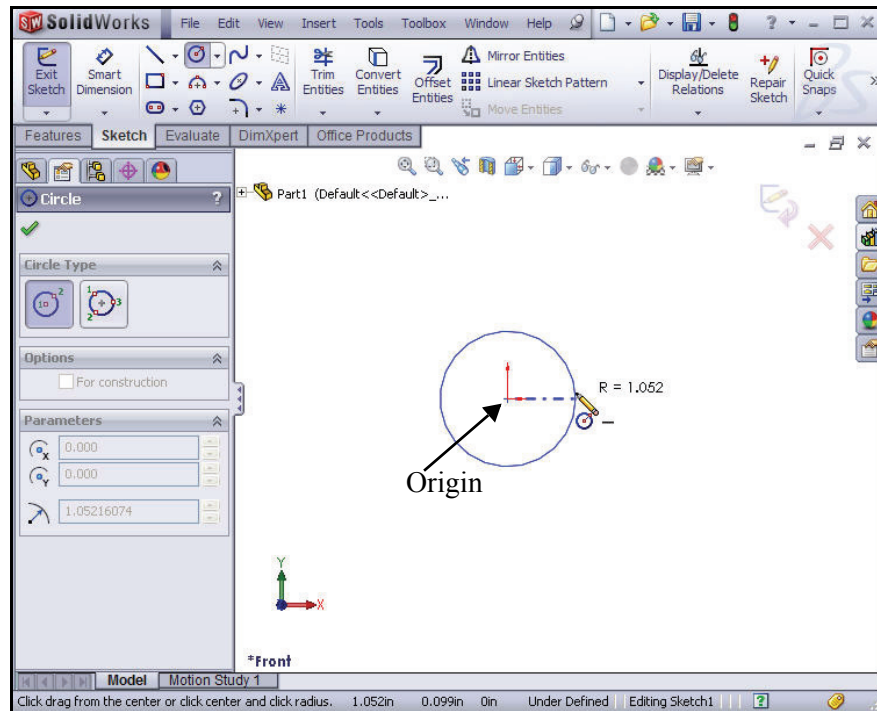

- Click the **Origin** of the circle. The cursor displays the Coincident to point feedback symbol as illustrated.
- Drag the **Mouse pointer** to the right of the Origin.
- Click a **position** in the Graphics window to create the circle as illustrated.



## Dimensioning the Sketch

### 1 Dimension the sketch.

- Click the **Smart Dimension**  Sketch tool. The Smart Dimension  icon is displayed.
- Click the **circumference** of the circle. The cursor displays the diameter feedback symbol.

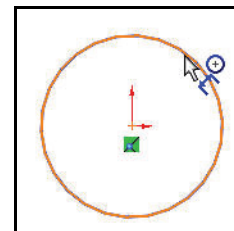

- Click a **position** diagonally above the circle in the Graphics window. A dimension is displayed in the Modify dialog box displaying the current value.
- Enter **.188[4.78]** in the Modify dialog box.
- Click the **green check mark**  from the Modify dialog box. This saves the current value and exits the Modify dialog box. The dimension of the circle is **.188[4.78]**.

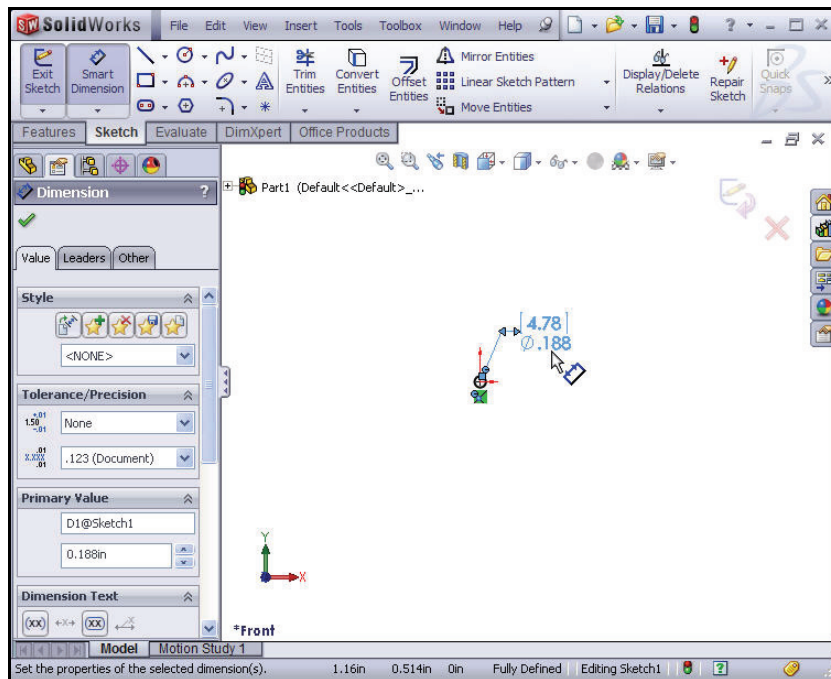
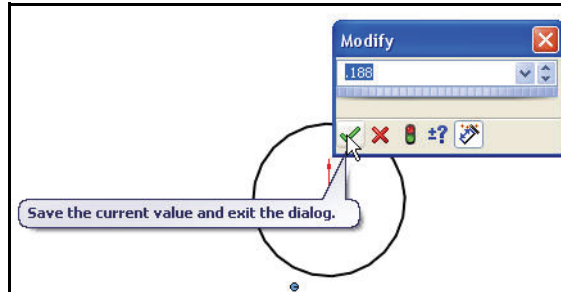

**Note:** The circular sketch is centered at the Origin. The dimension indicates the diameter of the circle is **.188[4.78]**. If your sketch is not correct, select the Undo  tool from the Menu bar toolbar.

## 2 Fit the model to the Graphics window.

- Press the **f** key on the keyboard. The model moves to the left.
- Click and drag the **dimension text** .188[4.78] closer to the sketch.
- **Perform** this procedure until you can clearly view the sketch as illustrated.
- If needed, click the **control point** to flip the dimension arrow head.

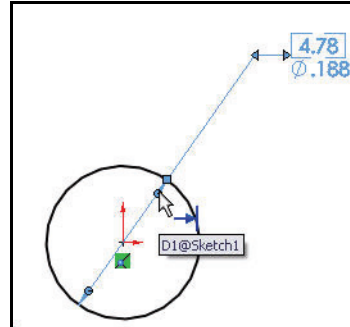

**Tip:** Press the **z** key to decrease the size of model in the Graphics window.

**Tip:** Press the **Shift + z** keys to increase the size of model in the Graphics window.

## 3 Deactivate the Smart Dimension tool.

- Right-click **Select** in the Graphics window.

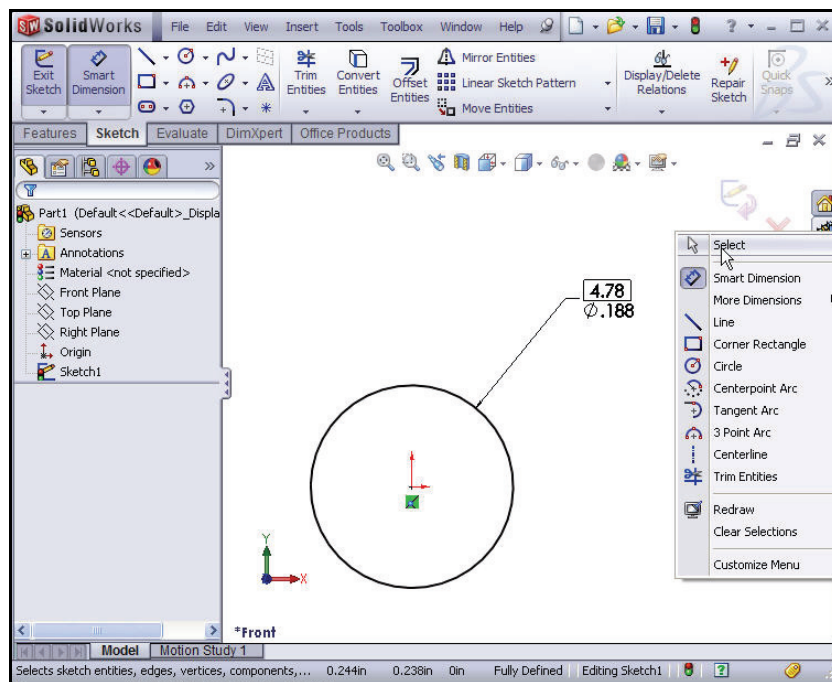



## Inserting an Extruded Base Feature

Start the translation of the initial design function and geometric requirement into SolidWorks features. What are features?

- Features are geometry building blocks.
- Features add or remove material.
- Features are created from sketched profiles or from edges and faces of existing geometry.

You will first utilize the Extruded Boss/Base feature. The Extruded Boss/Base feature adds material to the part. The Extruded Base feature is the first feature of the Axle. An extrusion extends the cylindrical profile along the path.

### 1 Insert an Extruded Base feature.

- Click the **Features** tab from the CommandManager as illustrated. The Features toolbar is displayed.
- Click the **Extruded Boss/Base**  Features tool. The Boss-Extrude PropertyManager is displayed.
- Select **Mid Plane** for the End Condition in Direction 1.
- Enter **1.375**[34.93] for Depth.
- Click **OK**  from the Boss-Extrude PropertyManager. Boss-Extrude1 is displayed in the FeatureManager.

### 2 Fit the model to the Graphics window.

- Press the **f** key.
- Click a **position** in the Graphics window. The Boss-Extrude PropertyManager displays the parameters utilized to define the feature. The Mid Plane End Condition in the Direction 1 box extrudes the sketch equally on both sides of the Sketch plane. The depth 1.375[34.93] defines the distance.

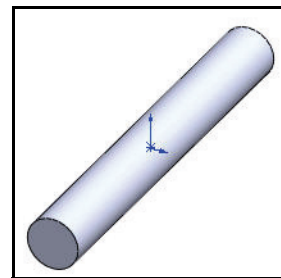
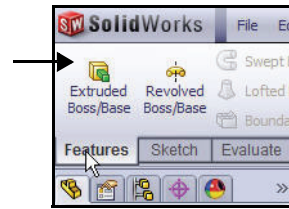

Extrude features add material. Extrude features require the following:

- Sketch plane.
- Sketch.
- Depth.



The Sketch plane is the Front Plane. The sketch is a circle with the diameter of .188in[4.78mm]. The depth is 1.375in[34.93mm].

**Tip:** The OK  button is just one way to accept and complete the process. A second method is the set of OK/Cancel buttons in the upper-right corner of the Graphics window.



## Saving the Axle Part

### 3 Save the Axle part.

- Click **File, Save**  or click **Save**  from the Menu bar toolbar.

- Select the Save in folder, **SolidWorks-Trebuchet**. This is the folder that you downloaded from the SolidWorks EDU Curriculum.

- Select **Part** from Save as type.
- Enter **Axle** for File name.
- Click **Save**. The extension, \*.sldprt is added automatically. The Axle FeatureManager is displayed.

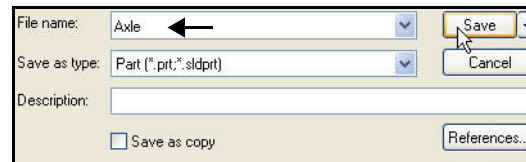

### 4 View Sketch1.

- **Expand** Boss-Extrude1 from the Axle FeatureManager. Sketch1 is displayed. Sketch1 is fully defined. In a fully defined sketch, all the lines and curves in the sketch and their positions are described by dimensions, relations, or both.

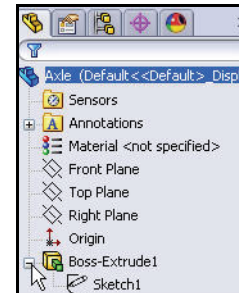

**Note:** With SolidWorks software, it is not necessary to fully dimension or define sketches before you use them to create features. However, you should always fully defined sketches before you consider the part complete for manufacturing.

Sketches are generally in one of the following states:

- **Fully defined.** All the lines and curves in the sketch, and their positions, are described by dimensions or relations, or both.
- **Over defined.** Some dimensions or relations, or both, are either in conflict or are redundant.
- **Under defined.** Some of the dimensions or relations in the sketch are not defined and are free to change.

**Note:** The SketchXpert PropertyManager is displayed as soon as you over-define a sketch.

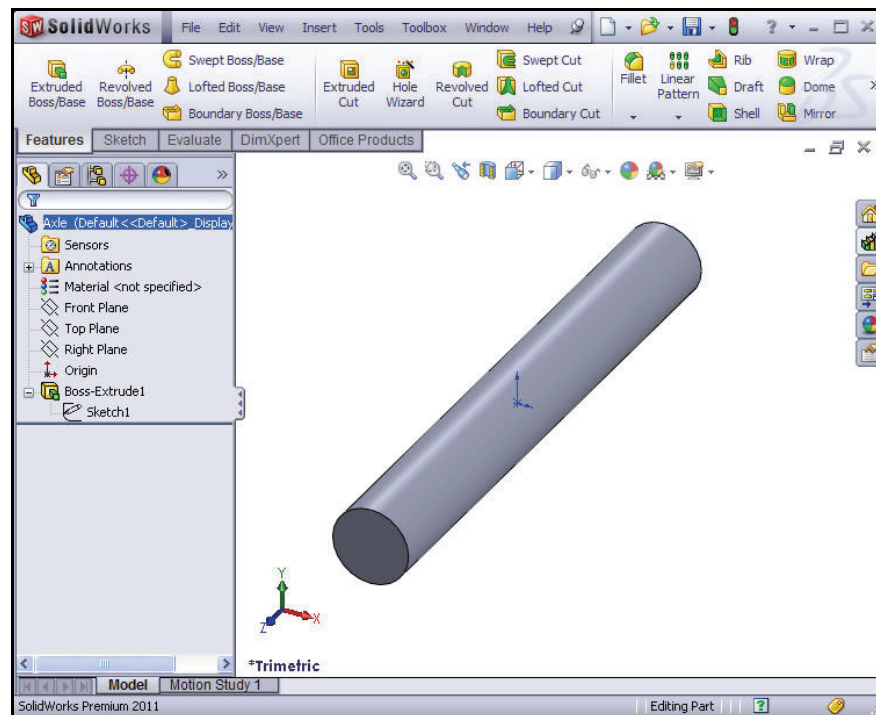

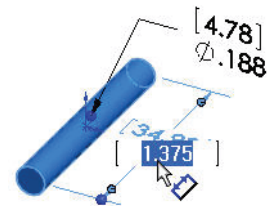
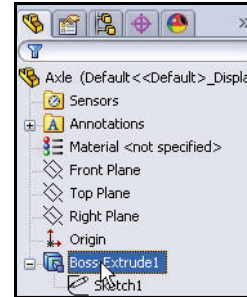

## Modifying the Dimension of the Axle

- 1 **View the Boss-Extrude1 dimension.**
  - Click **Boss-Extrude1** from the Axle FeatureManager. View the dimensions in the Graphic window.
  - Click and drag the **dimension text** off the model. The Dimension PropertyManager is displayed
  - Click the **1.375**[34.93] dimension text in the Graphics window as illustrated.

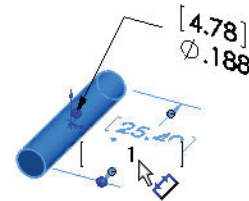

- 2 **Modify the length.**
  - Enter **1**[25.4].



- 3 **Save the model.**
  - Click **inside** the Graphics window.
  - Click **Save** .

**Tip:** Click or double-click a feature in the Graphics window or from the FeatureManager to display the dimensions.

**Note:** Click **View, Origins** from the Menu bar to view the Origin in the Graphics window.

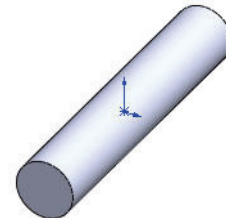

## Applying Material to the Axle

- 1 **Apply material to the Axle part.**
  - Right-click **Material** from the Axle FeatureManager.
  - Click **Edit Material**. The Materials dialog box is displayed. View your options.
  - **Expand** the Steel category.
  - Select **AISI 304**. View the properties.
  - Click **Apply**.
  - Click **Close**.

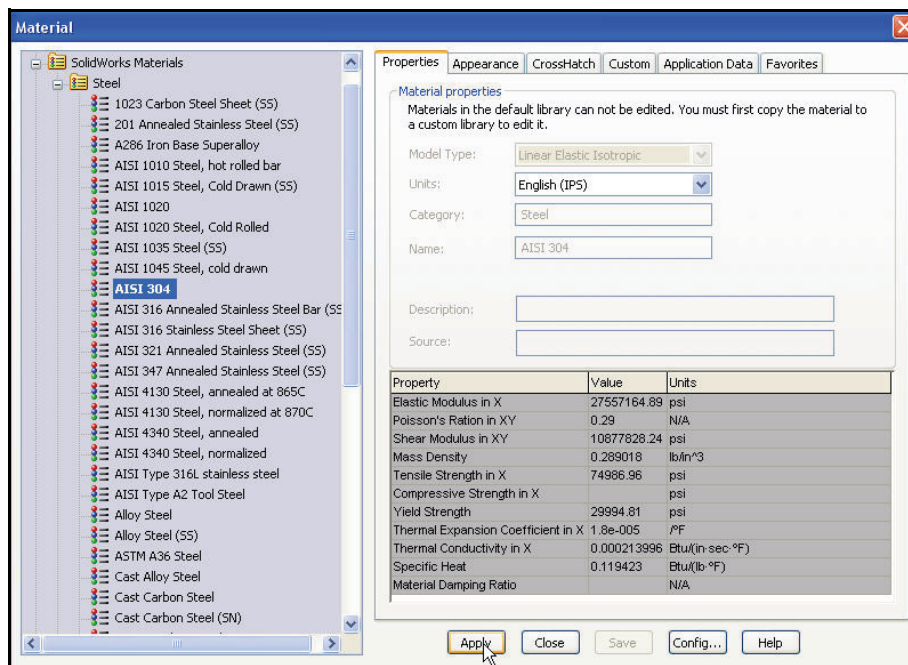
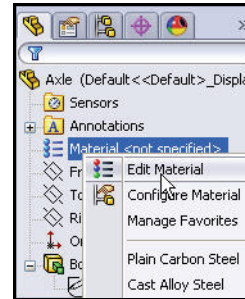

- View the updated Axle FeatureManager.

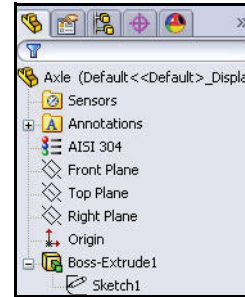



### Inserting a Chamfer Feature

**1 Orient the view.**

- Click **Isometric**  from the Heads-up View toolbar.

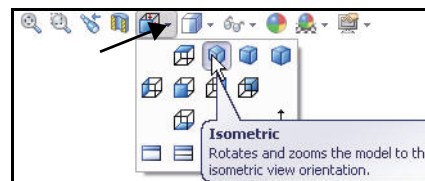
**Note:** Various modeling operations require you to view and select details of a model, no matter how small they might be. SolidWorks has numerous view manipulation tools that allow you to perform this function.



Zoom to Area , and Zoom to Fit  are a few examples of these tools.

**2 Insert a Chamfer feature.**

The Chamfer tool creates a beveled feature on selected edges, faces, or a vertex.

- Click the **Chamfer**  Features tool from the Consolidated drop-down Feature toolbar. The Chamfer PropertyManager is displayed.

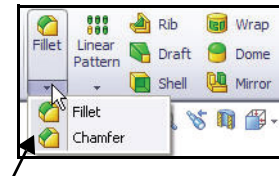

**3 Zoom out on the Axle.**

- Press the **z** key twice from the key board.

**4 Select the edges to chamfer.**

- Click the **front circular edge** of the Axle as illustrated. Edge <1> is displayed in the Chamfer Parameters box.

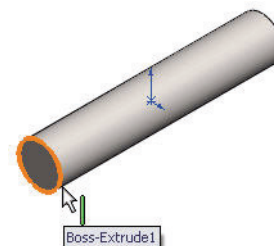

**Tip:** Press the **z** key to decrease the size of model in the Graphics window.

## SolidWorks

## Modeling the Trebuchet

**Tip:** Press the **Shift + z** keys to increase the size of model in the Graphics window.

- Click the **back circular edge** of the Axle. Edge<2> is displayed in the Chamfer Parameters box.

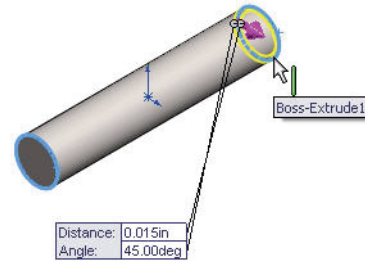

**5 Set the Chamfer distance and angle.**

- Enter **.015**[.38] for Distance.
- Enter **45** for Angle.

**6 Accept the default values and view the results.**

- Click **OK**  from the Chamfer PropertyManager.

Chamfer1 is displayed in the FeatureManager. The Axle is displayed in the Graphics window with the chamfer feature on the selected edges.

**7 View the dimensions.**

- Click **Chamfer1** in the FeatureManager. View the dimensions.

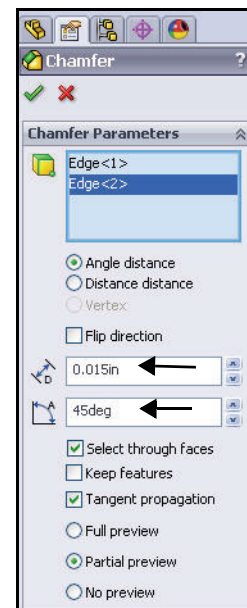

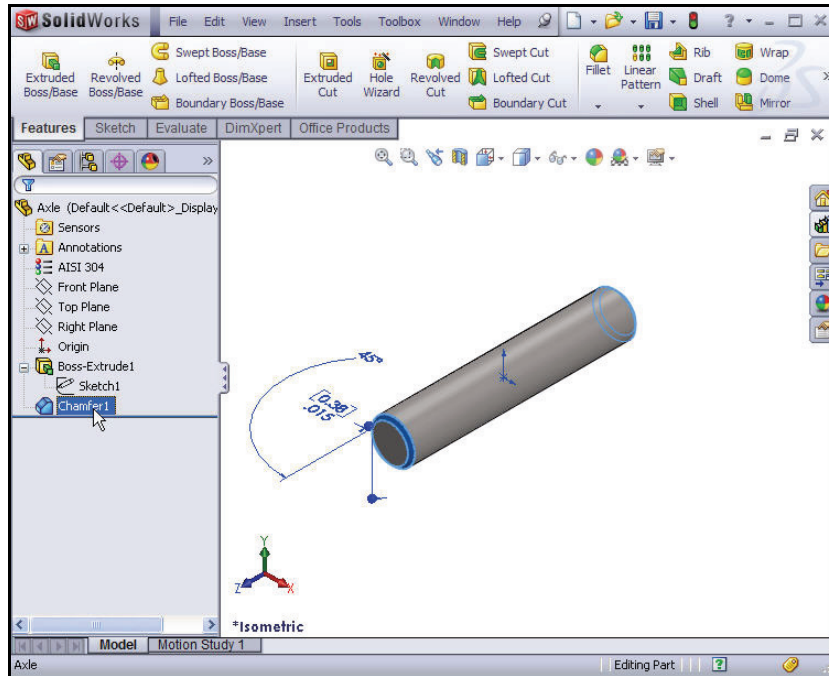

**8 Save the model.**

- Press the **Esc** key.
- Click **Save** .

**9 Close all models.**

- Click **Window, Close All** from the Menu bar toolbar. You just finished your first SolidWorks part!

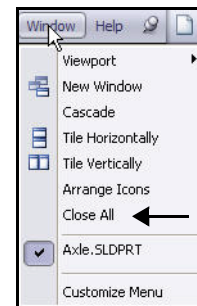

## PhotoView 360

PhotoView 360 is a software solution from SolidWorks, fully integrated into the SolidWorks software to create photo-realistic images directly from SolidWorks models.

Renderings can be created from SolidWorks parts and assemblies, but not drawings. PhotoWorks can produce photo-realistic images to add visual impact to your presentations and documents.

Some of the key features of PhotoView 360 are:

- **Fully integrated into SolidWorks:** PhotoView 360 software is supplied as a SolidWorks dynamic link library, .dll add-in. The menu bar is displayed whenever a SolidWorks part or assembly document is open.
- **Appearances:** Appearances are used in PhotoView 360 to specify model surface properties such as color, texture, reflectance, and transparency. PhotoWorks is supplied with numerous predefined appearances. Other appearances can be downloaded from web sites.
- **Lighting:** Lights may be added in the same way a photographer adds lights when taking photographs. PhotoView 360 contains numerous predefined lighting schemes to simplify and speed up the rendering process.
- **Scenes:** Each SolidWorks model is associated with a PhotoView 360 scene, for which you can specify properties such as rooms, environments, and backgrounds.
- **Decals:** Images, such as company logos, can be applied to models.
- **Output:** PhotoView 360 can output to the screen, a printer, or a graphics file.

In the next section, you will use the PhotoView 360. You will then use additional features and functions of PhotoView 360 throughout the book.

## Creating a Photorealistic Image

### 1 Open the Axle part.

- Click **Open**  from the Menu bar menu.
- Select the **SolidWorks-Trebuchet** folder.
- Select **Part** from Files of type.
- Double-click **Axle**. The Axle FeatureManager is displayed. The Axle is displayed in the Graphics window.

- 2 **Activate PhotoView 360.**
    - Click the **Office Products** tab in the CommandManager.
    - Click **PhotoView 360**. The PhotoView 360 button is displayed in the Menu bar toolbar.
  - 3 **Create a PhotoView Scene.**
    - Click **PhotoView 360** from the Menu bar toolbar.
    - Click **Edit Scene** from the drop-down menu. Click **Yes** if needed. The Edit Scene PropertyManager is displayed.
- Tip:** You can also select PhotoWorks Studio from the PhotoWorks toolbar. To activate the PhotoWorks toolbar, click **View, Toolbars, PhotoWorks** from the Menu bar toolbar.
- 4 **Set the Scenery.**
    - Expand the **Scenes** folder in the Task Pane.
    - Click the **Presentation Scenes** folder as illustrated. View your options.
    - Drag and drop **Kitchen Background** in the graphics area. View the results.

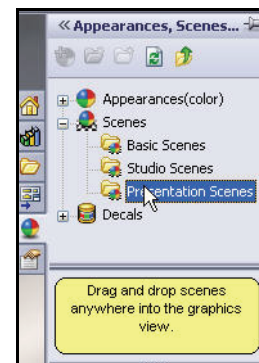
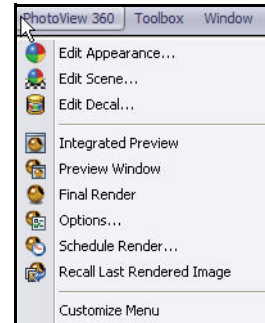
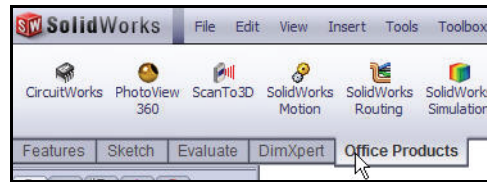

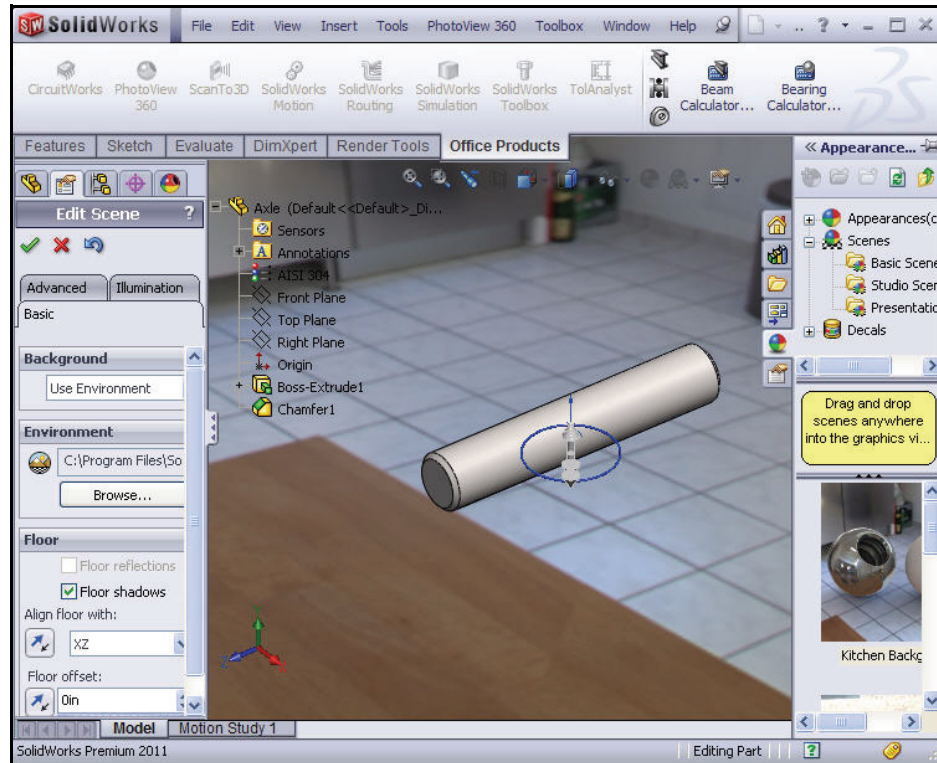

**5 Close Edit Scene.**

- Click **OK**  from the Edit Scene PropertyManager.

**6 De-render the model.**

- Press the **z** key.

**Note:** The Apply Scene  tool from the Heads-up View toolbar provides the ability to modify the model back ground in your Graphics window.

## Creating the Shaft Collar Part

### 1 Create the Shaft Collar part.

- Click **New**  from the Menu bar toolbar. The Templates tab is the default tab. Part is the default template from the New SolidWorks Document dialog box.

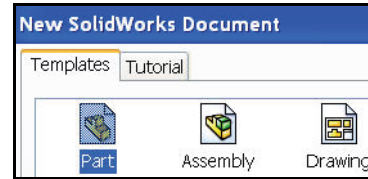

- Click **OK**. The Part2 FeatureManager is displayed.

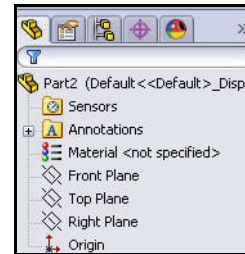

### 2 Save the part.

- Click **Save As** from the Menu bar Consolidated toolbar.
- Select the Save in folder, **SolidWorks-Trebuchet**.
- Select **Part** from Save as type.
- Enter **Shaft Collar** for File name.
- Click **Save**. The extension, \*.sldprt is added automatically. The Shaft Collar FeatureManager is displayed.

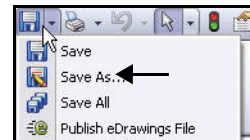

### 3 Set the Drafting Standard.

- Click **Options** , **Document Properties** tab from the Menu bar toolbar. The Document Properties - Drafting Standard dialog box is displayed.
- Select **ANSI** from the drop-down menu for Drafting Standard.

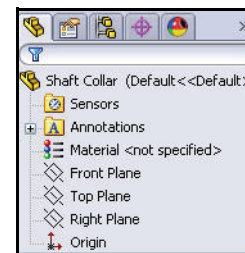
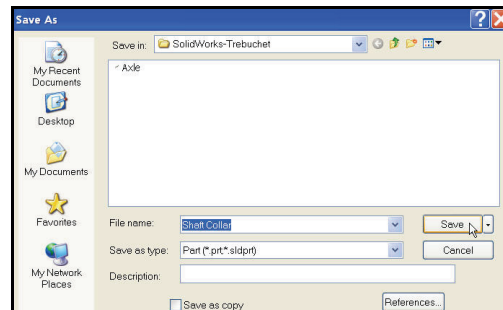

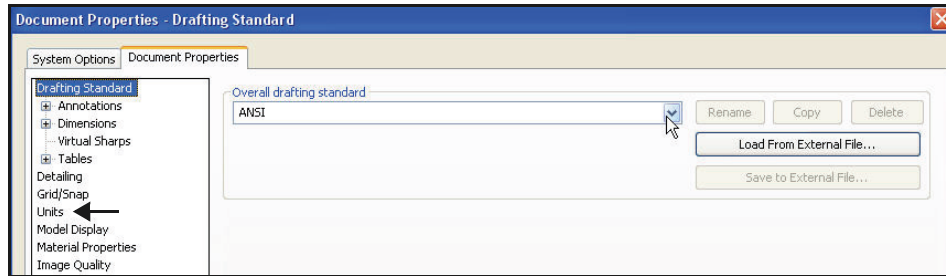

**4 Set unit system and length.**

- Click **Units**.
- Click **IPS** (inch, pound, second) for Unit system.
- Select **.123** for Length unit decimal place.
- Select **None** for Angle decimal place.
- Select **millimeters** for Dual Dimension Length.

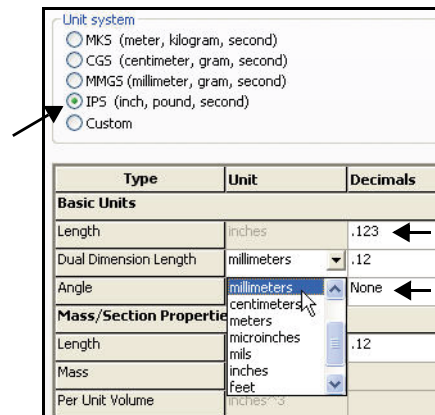

**5 Set dual unit display.**

- Click **Dimensions** from the Document Properties dialog box.
- Check the **Dual dimensions display** box.

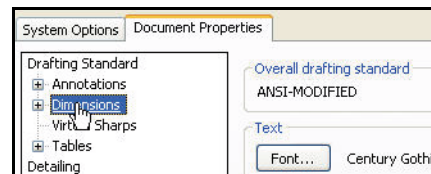

**6 Set System options.**

- Click **OK** from the Document Properties-Dimensions dialog box.



## 7 Open a sketch.

- Right-click **Front Plane** from the FeatureManager.
- Click **Sketch**  from the Context toolbar. The Sketch toolbar is displayed.

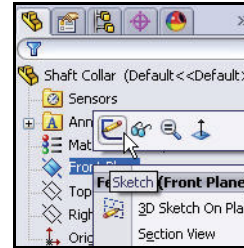

## 8 Sketch a circle with a center point at the Origin.

- Click the **Circle**  Sketch tool.
- Click the **Origin** of the circle. The cursor displays the Coincident to point feedback symbol.
- Drag the **Mouse pointer** to the right of the Origin as illustrated.

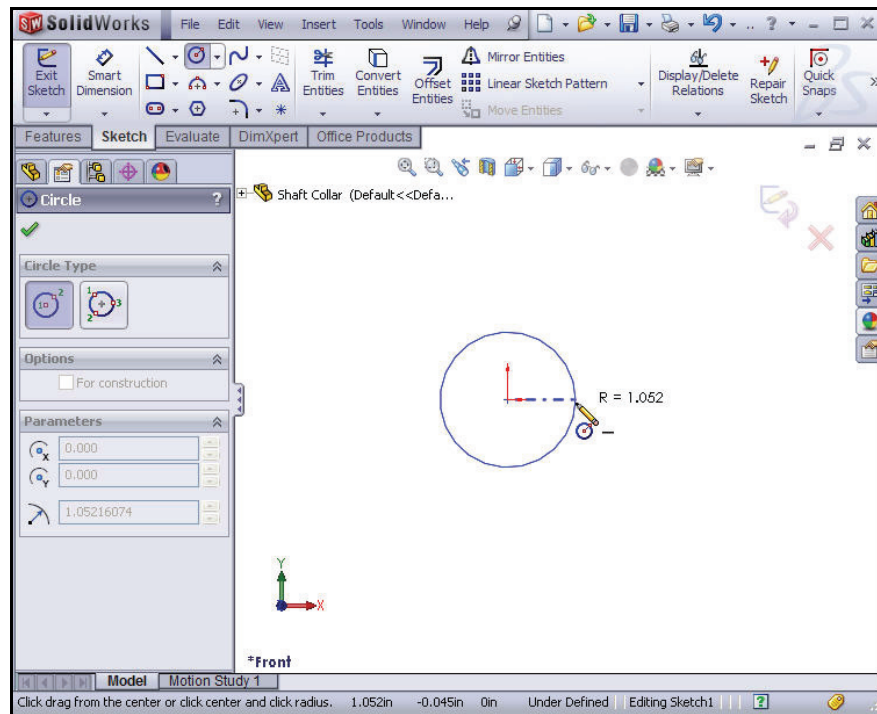
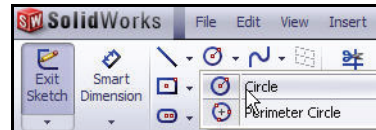

## SolidWorks

## Modeling the Trebuchet

- Click a **position** in the Graphics window to create the circle.



### 9 Add a dimension.

- Click the **Smart Dimension**  Sketch tool.

**Note:** View the mouse pointer  icon.

- Click the **circumference** of the circle. The cursor displays the diameter feedback symbol.
- Click a **position** diagonally above the circle in the Graphics window. A dimension is displayed in the Modify box.
- Enter **.469**[11.91] in the Modify box.
- Click the  button from the Modify dialog box.

### 10 View the results.

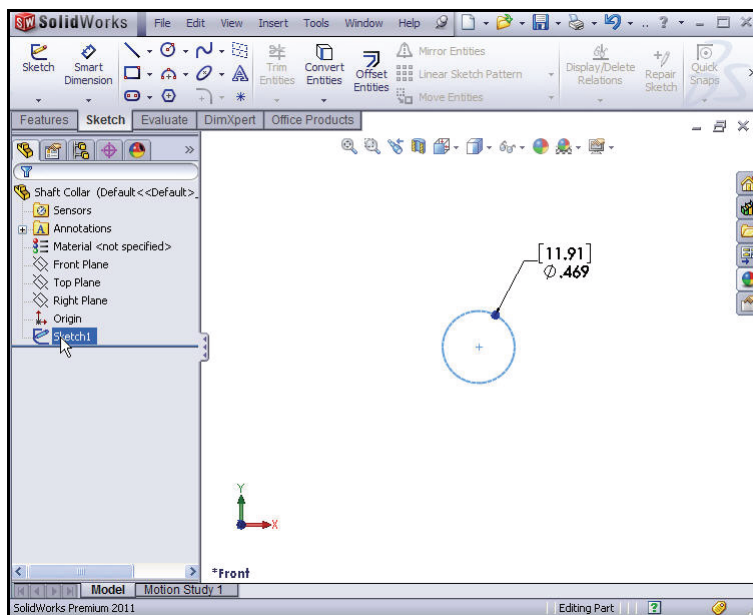
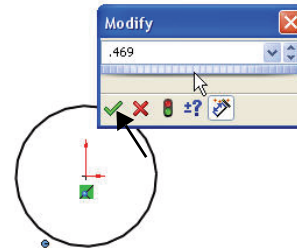
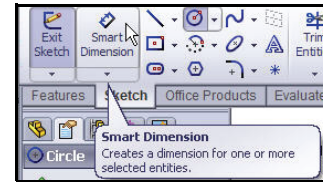

- Click **OK**  from the Dimension PropertyManager.
- Click the **Rebuild**  tool from the Menu bar toolbar.
- Click **Sketch1** from the Shaft Collar FeatureManager. Sketch1 is highlighted. The dimension is displayed in the Graphics window.

**Note:** If needed, fit the drawing to the Graphics window.





## Inserting an Extruded Base Feature

### 1 Insert an Extruded Base feature.

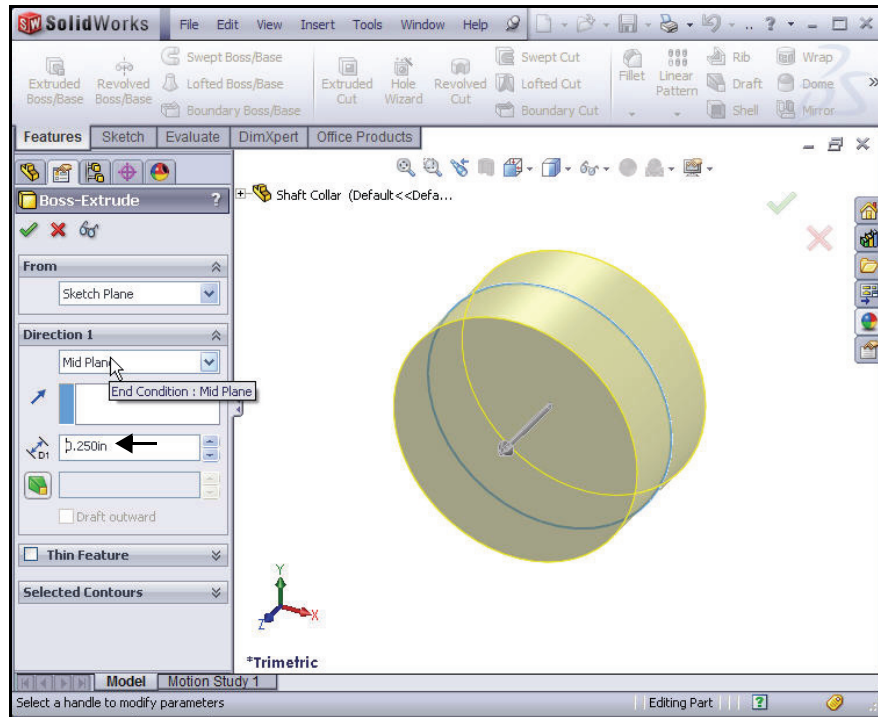
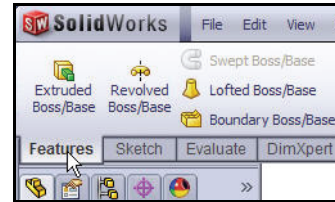
- Click the **Features** tab from the CommandManager.
- Click the **Extruded Boss/Base**  Features tool. The Boss-Extrude PropertyManager is displayed.
- Select **Mid Plane** for End Condition in Direction 1.
- Enter **.250**[6.35] for Depth.
- Click **OK**  from the Boss-Extrude PropertyManager. Boss-Extrude1 is displayed in the Shaft Collar FeatureManager.



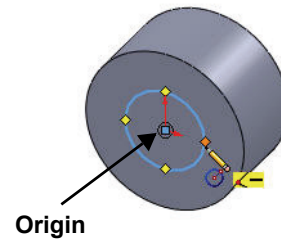
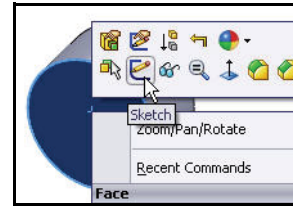

## Inserting a new Sketch

- 2 **Insert a new sketch for the Extruded Cut feature.**
  - Right-click the **front circular face** of the Extrude1 feature for the Sketch plane. Extrude1 is highlighted in the FeatureManager
  - Click **Sketch**  from the Context toolbar. The Sketch toolbar is displayed.
  - Click the **Circle**  Sketch tool.
  - Click the **Origin**. The cursor displays the Coincident to point feedback symbol.
  - Drag the **mouse pointer** to the right of the Origin.
  - Click a **position** in the Graphics window to create the circle.



## Adding a Dimension

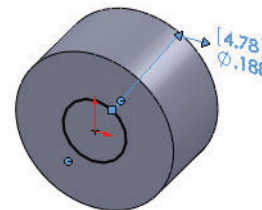
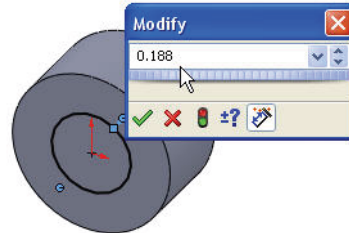

- 3 **Add a dimension.**
  - Click the **Smart Dimension**  Sketch tool.
  - Click the **circumference** of the circle. The cursor displays the diameter feedback symbol.
  - Click a **position** diagonally above the circle in the Graphics window. A dimension appears with the Modify box displaying the current value.
  - Enter **.188[4.78]** in the Modify box.
  - Click the  button from the Modify box. The sketch is fully defined.



## Inserting an Extruded Cut Feature

An Extruded Cut feature removes material. The Extruded Cut begins with a 2D sketch on the front face.

### 1 Insert an Extruded Cut feature.

- Click the **Features** tab from the CommandManager.
- Click the **Extruded Cut**  Features tool. The Cut-Extrude PropertyManager is displayed.
- Select **Through All** for End Condition in Direction 1. The Through All End Condition removes material from the Front Plane through the Boss-Extrude1 feature. Note the direction of the Extrude feature.
- Click **OK**  from the Cut-Extrude PropertyManager. Cut-Extrude1 is displayed in the FeatureManager.

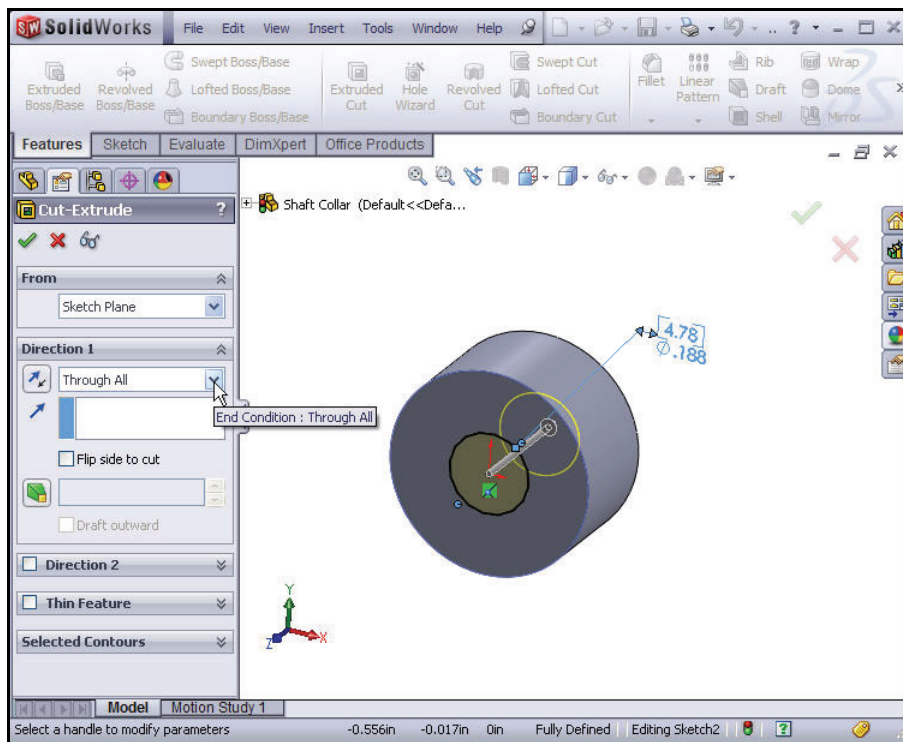
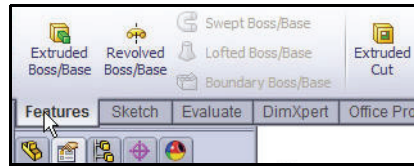

## Inserting a Chamfer Feature

### 1 Insert a Chamfer feature.

- Click the **Chamfer**  Features tool from the Consolidated drop-down toolbar. The Chamfer PropertyManager is displayed.

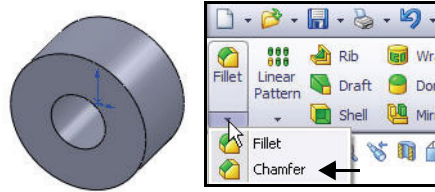

### 2 Select the chamfer edges.

- Click the **front circular edge** of the Shaft Collar as illustrated. View the default dimensions. Edge <1> is displayed in the Chamfer Parameters box.

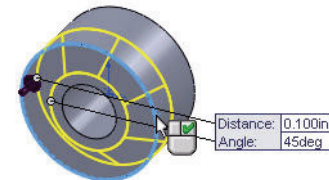

- Click the **back circular edge** of the Shaft Collar. View the default dimensions. Edge <2> is displayed in the Chamfer Parameters box.

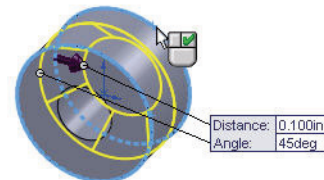

### 3 Set the Chamfer distance and angle.



- Enter **.010**[.25] for Distance.
- Enter **45** for Angle.

### 4 Accept the default values and view the results.

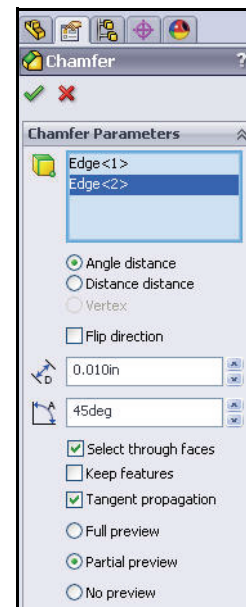
- Click **OK**  from the Chamfer PropertyManager. Chamfer1 is displayed in the Shaft Collar FeatureManager.



5 Save the model.

- Click **Isometric**  view.
- Click **Save** . View the results in the Graphics window.

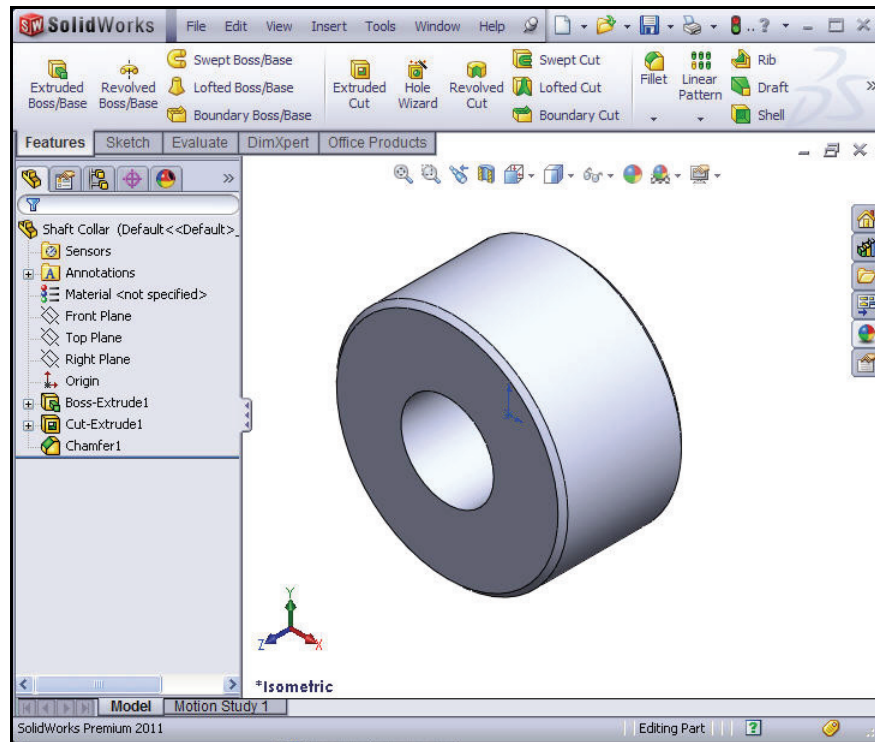
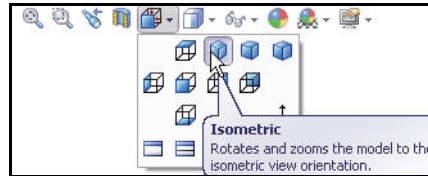

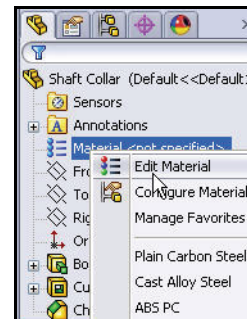

Applying Material to the Shaft Collar

- 1 Apply material to the Shaft Collar.
  - Right-click **Material** from the Shaft Collar FeatureManager.
  - Click **Edit Material**. The Material dialog box is displayed.

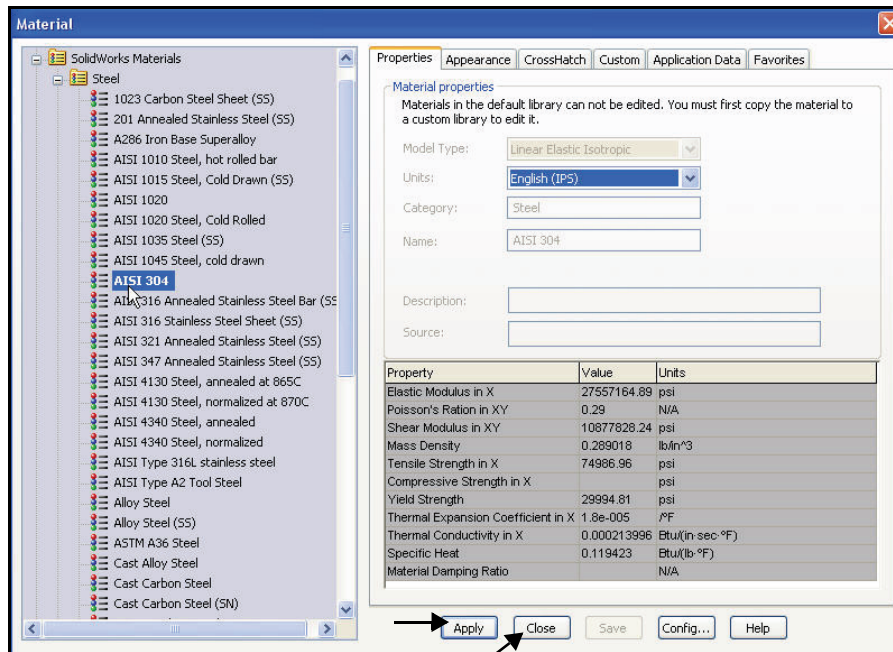

- Expand the Steel category.
- Click **AISI 304**. View the material properties.
- Click **Apply**.
- Click **Close**.



- AISI 304 is displayed in the Shaft Collar FeatureManager.
- 2 Save the model.
- Click **Save** .

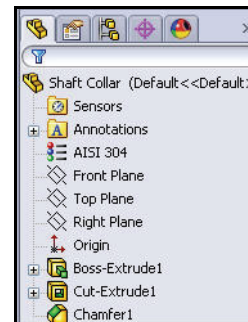

## Exploring the DisplayManager Tab and Applying Appearance

- 1 **Activate PhotoView 360.**
  - Click the **Office Products** tab in the CommandManager.
  - Click **PhotoView 360**. The PhotoView 360 button is displayed in the Menu bar toolbar.
- 2 **View the DisplayManager Tab.**
  - Click the **DisplayManager**  tab as illustrated.

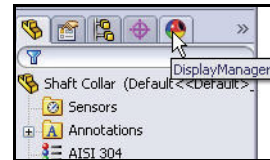
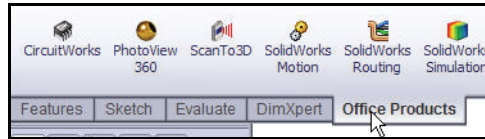

The Shaft Collar DisplayManager is displayed. The DisplayManager tab provides an outline view of the Appearances, Decals and Scene, lights, and cameras effects associated with the active SolidWorks part or assembly.

The DisplayManager also makes it easy to:

- Understand the way in which appearances and decal inheritance works.
- Select and edit appearances and decals associated with the model.
- Transfer appearances and decals between components, features, and faces.

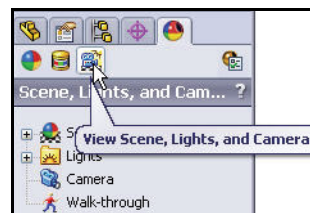
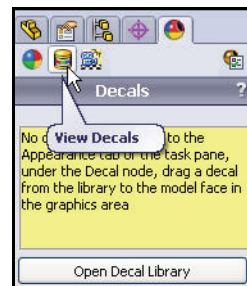

### 3 Explore PhotoView 360 Help.

- Click **Help, SolidWorks Help** from the Menu bar toolbar.
- Enter **PhotoView 360** under the Index tab.
- Click **List Topics**. View the help information.

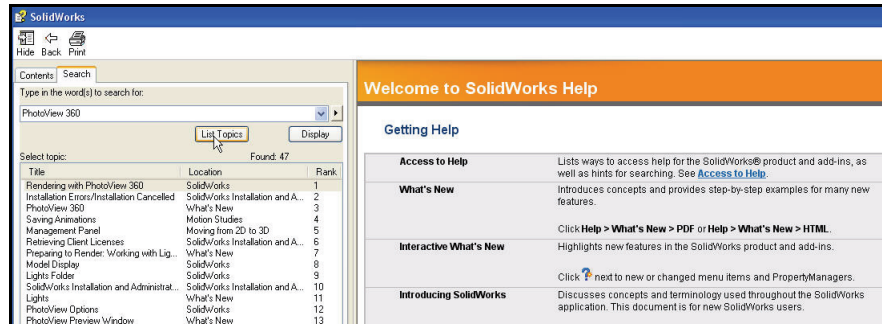

### 4 Close the SolidWorks help box.

- Click **Close** .

### 5 Activate the Appearances, Scenes, and Decals option in the Task Pane.

- Click the **Appearances, Scenes, and Decals**  tab from the Task Pane. View the default categories: *Appearances(color)*, *Scenes*, and *Decals*.

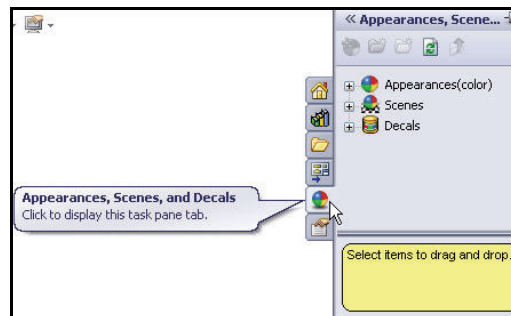

6 Apply an Appearance.

- **Expand** Appearances(color).
- **Expand** Metals.
- Click **Brass**.
- Drag and drop **matte brass** onto the model.
- Click the **Shaft Color** icon. View the results. This option provides the ability to either select a face, feature or the entire model.

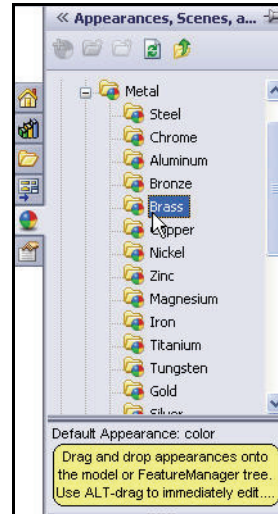
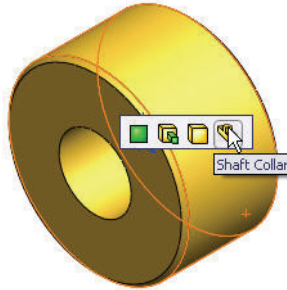

7 Return to the Shaft Collar FeatureManager.

- Click the **Part FeatureManager**  tab as illustrated.

8 Save the model.

- Click **Save** .

9 Close all models.

- Click **Window, Close All** from the Menu bar toolbar. You created your second part.

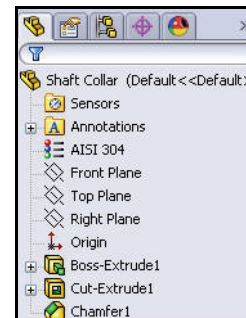

## Creating the 7 Hole Flatbar Part

### 1 Create the 7 Hole Flatbar.

- Click **New**  from the Menu bar toolbar. The Templates tab is the default tab. Part is the default template from the New SolidWorks Document dialog box.
- Click **OK**. The Part3 FeatureManager is displayed.

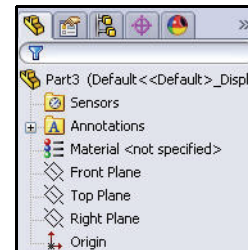
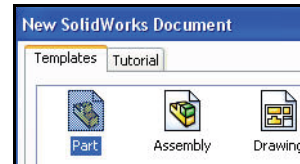

### 2 Save the part.

- Click **Save As** from the Menu bar Consolidated toolbar.
- Select the Save in folder, **SolidWorks-Trebuchet**.
- Select **Part** from Save as type.
- Enter **7 Hole Flatbar** for File name.
- Click **Save**.

The extension, \*.sldprt is added automatically. The 7 Hole Flatbar FeatureManager is displayed.

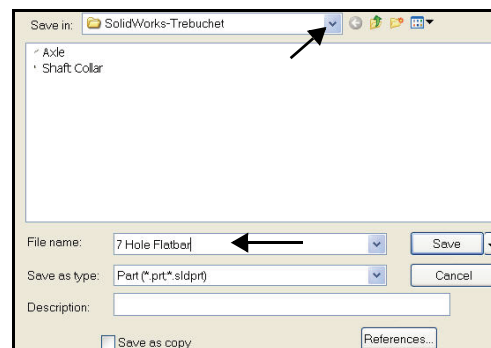
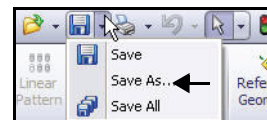

### 3 Set Drafting Standard.

- Click **Options** , **Document Properties** tab from the Menu bar toolbar. The Document Properties - Drafting Standard dialog box is displayed.
- Select **ANSI** from the drop-down menu for Drafting Standard.

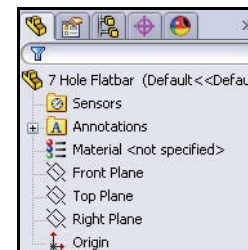

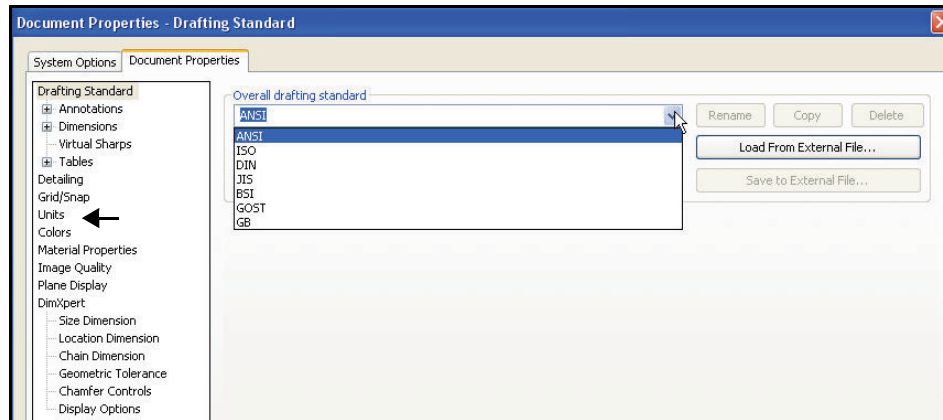

**4 Set unit system and length.**

- Click **Units**.
- Click **IPS** (inch, pound, second) for Unit system.
- Select **.123** for Length unit decimal place.
- Select **None** for Angle decimal place.
- Select **millimeters** for Dual Dimension Length.

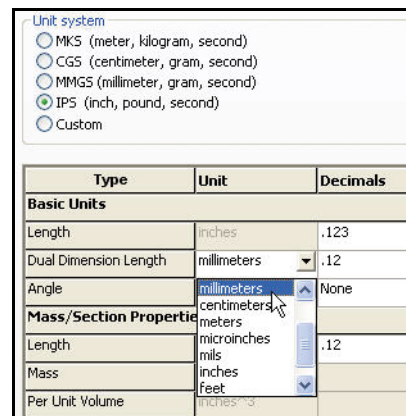

**5 Set dual unit display.**

- Click **Dimensions** from the Document Properties dialog box.
- Check the **Dual dimensions display** box.

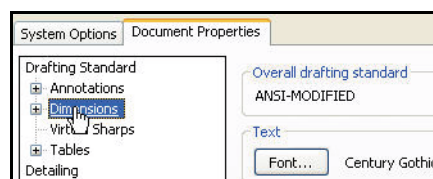

**6 Set System options.**

- Click **OK** from the Document Properties-Dimensions dialog box.

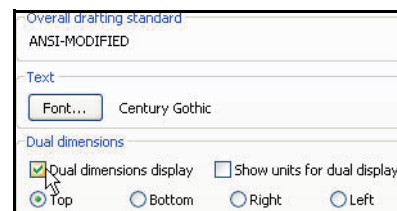

**7 Select the Sketch plane.**

- Right-click **Front Plane** from the 7 Hole Flatbar FeatureManager. Front Plane is highlighted in the FeatureManager.

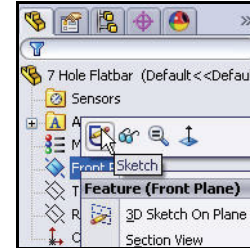
**8 Create a slot sketch.**

- Click **Sketch**  from the Context toolbar.

- Click the **Centerpoint Straight Slot**  tool from the Consolidated Sketch toolbar. The Centerpoint Straight Slot sketches a straight slot from the centerpoint.

**Note:** The SolidWorks application defaults to the last used tool in a Consolidated toolbar.

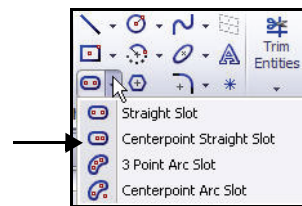

- Click the **Origin** for the center of the slot.
- Click a **position** directly to the right of the Origin.
- Click a **position** directly above the right point as illustrated.

The slot sketch is symmetric about the Origin.

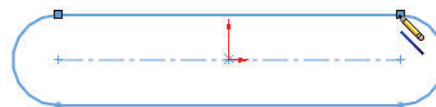
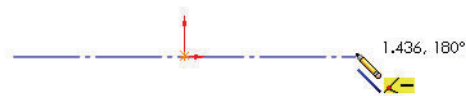

**Note:** If needed, utilize relations. A relation is a geometric constraint between sketch geometry.

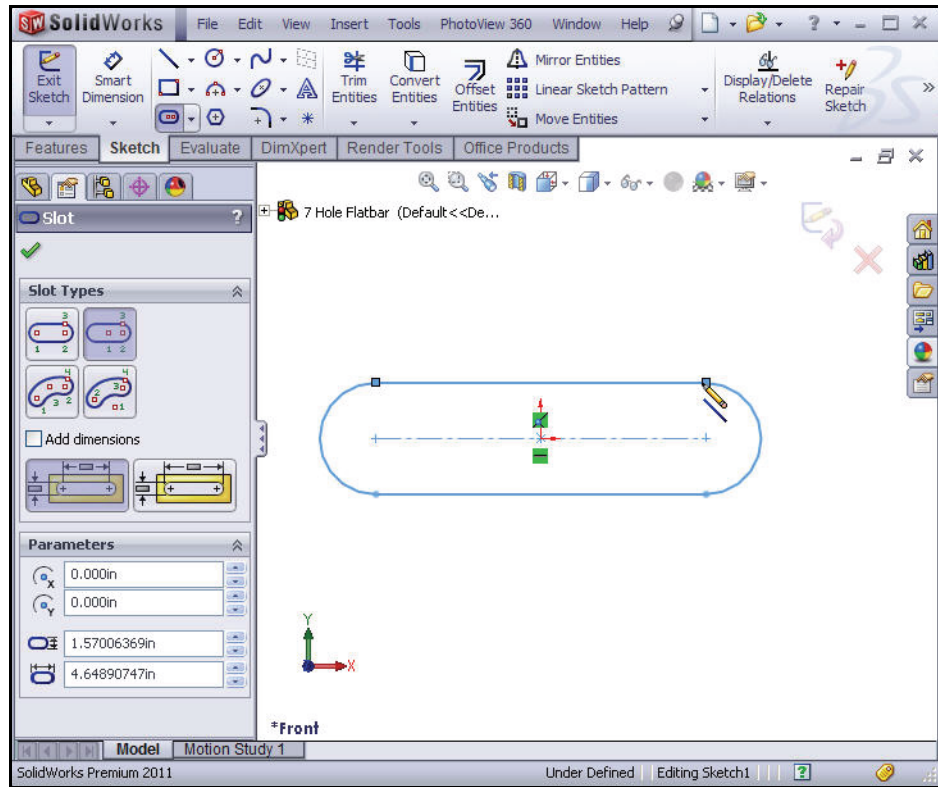





## Adding Dimensions

### 1 Add a horizontal dimension.

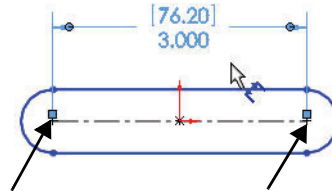
- Click the **Smart Dimension**  Sketch tool.
- Click the **centerpoint** of the left Tangent Arc.
- Click the **centerpoint** of the right Tangent Arc.
- Click a **position** above the top horizontal line in the Graphics window.
- Enter **3.000**[76.2] in the Modify dialog box.
- Click the  button from the Modify dialog box.





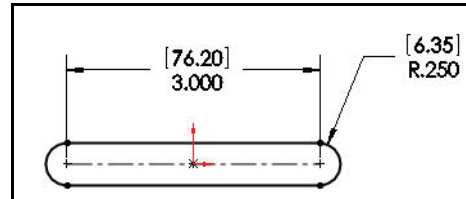
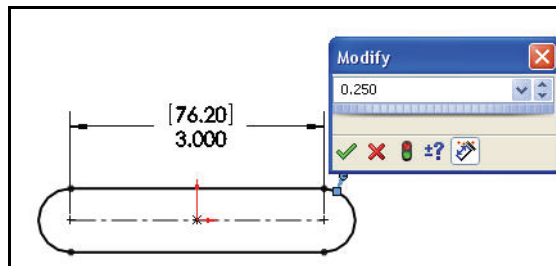

### 2 Add a radial dimension.

- Click the **right arc** of the 7 Hole Flatbar.
- Click a **position** diagonally to the right in the Graphics window.
- Enter **.250**[6.35] in the Modify dialog box.
- Click the  button from the Modify dialog box.
- Click **OK**  from the Dimension PropertyManager. The black sketch is fully defined.



## Inserting an Extruded Base Feature

- 1 **Insert an Extruded Base feature.**
  - Click the **Features** tab from the CommandManager.
  - Click the **Extruded Boss/Base**  Features tool. The Boss-Extrude PropertyManager is displayed. Blind is the default End Condition in Direction 1.
  - Enter **.060**[1.52] for Depth.
  - Click **OK**  from the Boss-Extrude PropertyManager. Boss-Extrude1 is displayed.
- 2 **Fit the model to the Graphics window.**
  - Press the **f** key.
- 3 **Save the model.**
  - Click **Isometric**  view from the Heads-up View toolbar.
  - Click **inside** the Graphics window.
  - Click **Save** .

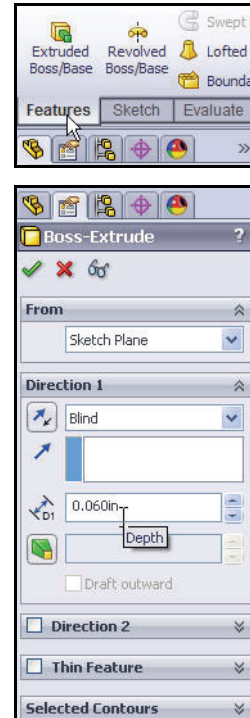

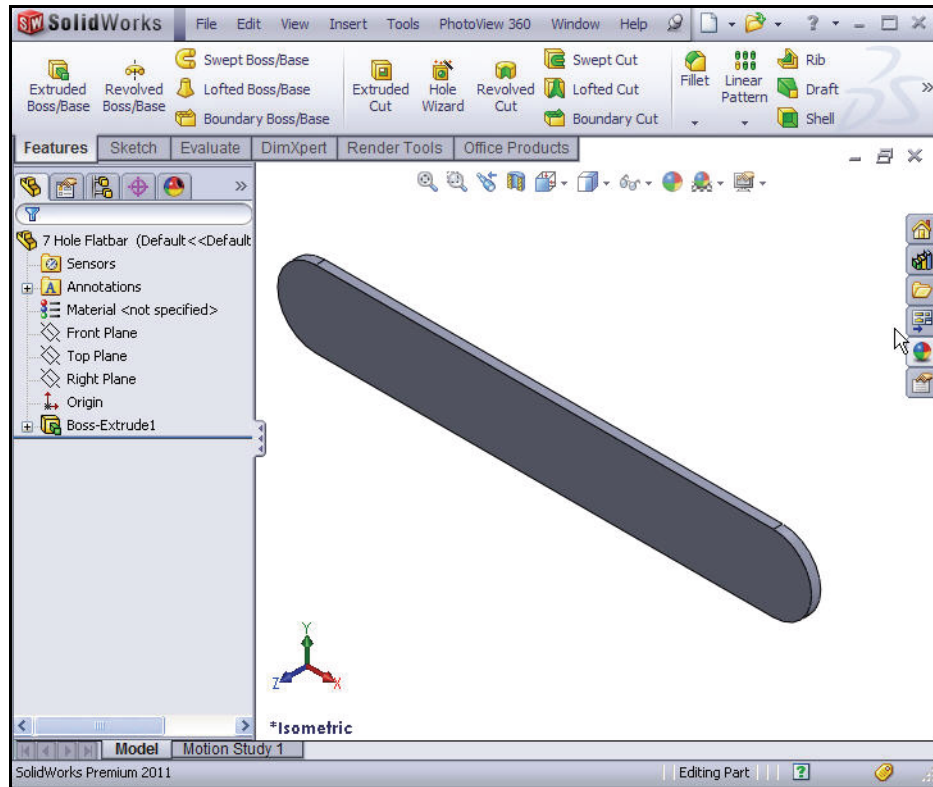

## Inserting an Extruded Cut Feature

- 1 **Insert a new sketch for the Extruded Cut feature.**
  - Right-click the **front face** of the 7 Hole Flatbar model. This is your Sketch plane. Boss-Extrude1 is highlighted in the FeatureManager.

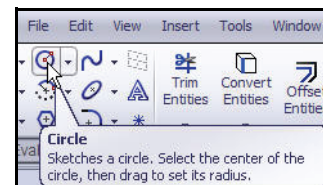
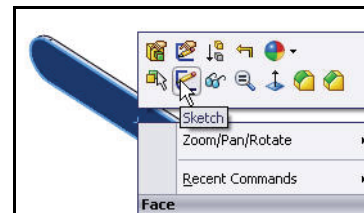

**Note:** The process of placing the mouse pointer over an existing arc to locate its center point is called “wake up”. You will perform this task.

- 2 **Wake up the center point.**
  - Click **Sketch**  from the Context toolbar. The Sketch toolbar is displayed.



## Modeling the Trebuchet

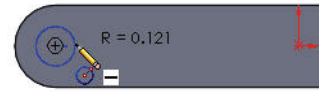

SolidWorks

- Click **Front view**  from the Heads-up View toolbar.
- Click the **Circle**  Sketch tool. The Circle PropertyManager is displayed.
- Place the **mouse pointer** on the left arc as illustrated. Do not click. The center point of the slot arc is displayed.
- Click the **center point** of the arc.
- Click a **position** to the right of the center point to create the circle as illustrated.



## Adding a Dimension

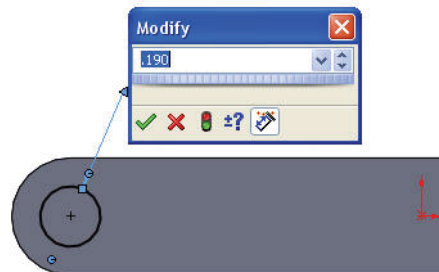

### 1 Add a dimension.

- Click the **Smart Dimension**  Sketch tool.
- Click the **circumference** of the circle. The cursor displays the diameter feedback symbol.
- Click a **position** diagonally above and to the right of the circle in the Graphics window. A dimension appears with the Modify box displaying the current value.
- Enter **.190**[4.83] in the Modify box.
- Click the  button from the Modify dialog box. The black sketch is fully defined.



## Inserting an Extruded Cut

### 1 Insert an Extruded Cut feature.

- Click **Isometric**  view from the Heads-up View toolbar.
- Click the **Features** tab from the CommandManager.
- Click the **Extruded Cut**  Features tool. The Cut-Extrude PropertyManager is displayed.
- Select **Through All** for End Condition in Direction 1. The Through All End Condition removes material from the Front Plane through the Boss-Extrude1 feature.
- Click **OK**  from the Cut-Extrude PropertyManager. Cut-Extrude1 is displayed in the FeatureManager.

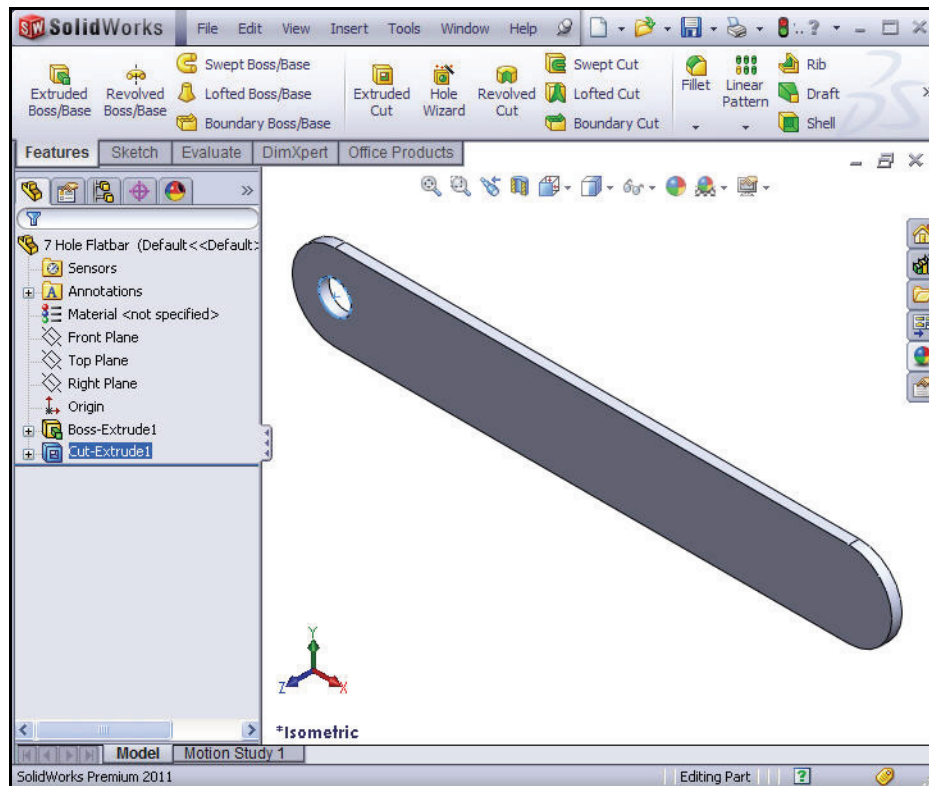
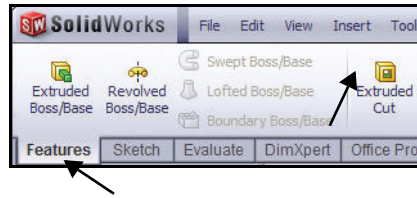

## 2 Save the model.

- Click **Save** .
- Click **inside** the Graphics area.
- Click **Cut-Extrude1** from the FeatureManager. The Cut-Extrude1 feature is displayed in blue. The blue Cut-Extrude1 icon indicates that the feature is selected.

Select features by clicking their icon in the FeatureManager or selecting geometry in the Graphics window.

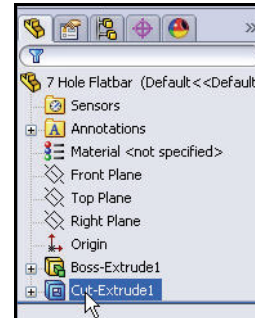

## Inserting a Linear Pattern feature

Use the Linear Pattern  tool to create multiple instances of one or more feature that you can space uniformly along one or two linear paths.

### 1 Insert a Linear Pattern.

- Click the **Linear Pattern**  Features tool. The Linear Pattern PropertyManager is displayed.
- Click the **top front edge** of the Boss-Extrude1 feature in the Graphics window for Direction 1.
- The Direction arrow points to the right. Click the **Reverse Direction** button if required. Edge<1> is displayed in the Pattern Direction box for Direction1.
- Enter **0.5**[12.7] for Spacing.
- Enter **7** for Number of Instances. Instances are the number of occurrences of a feature.

**Note:** If Cut-Extrude1 is not displayed in the Features to Pattern, perform the following tasks:

- Click inside the **Features to Pattern** box.
- **Expand** the 7 Hole FeatureManager in the Graphics window.

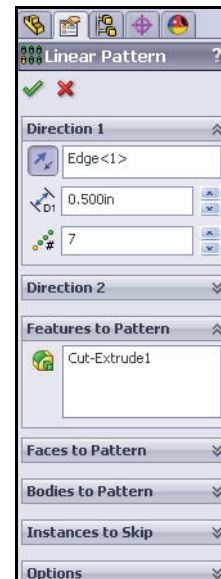
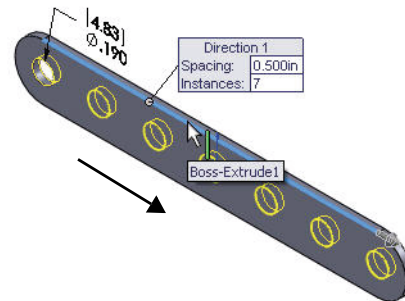

- Click **Cut-Extrude1** from the FeatureManager. Cut-Extrude1 is displayed in the Features to Pattern box.

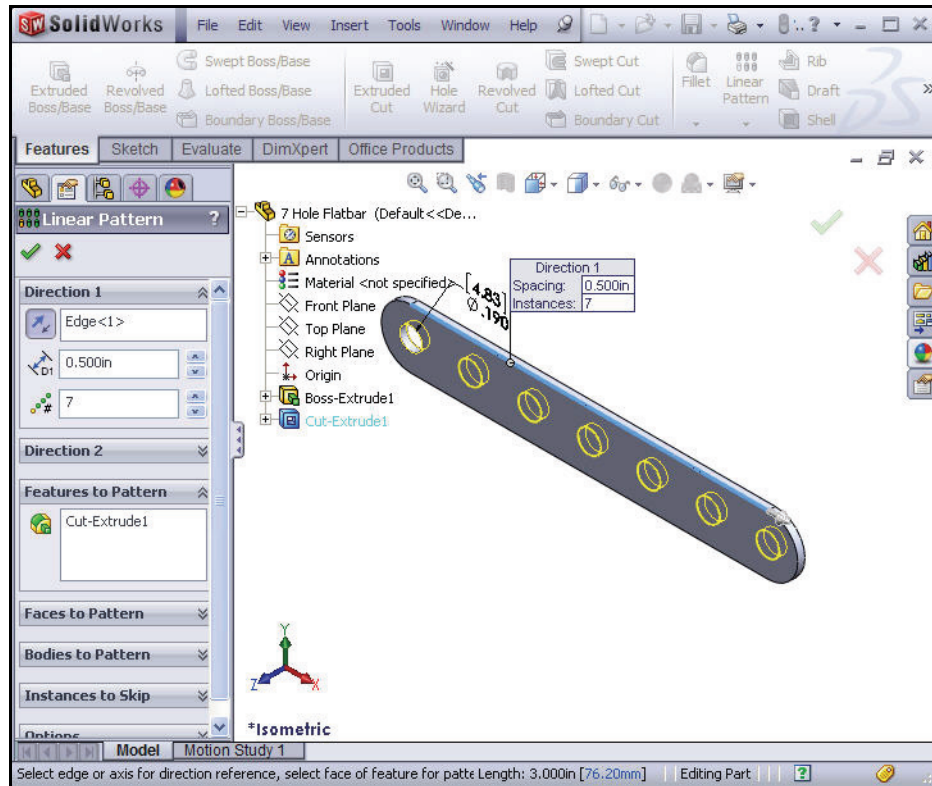

- Click **OK**  from the Linear Pattern PropertyManager. The LPattern1 feature is displayed in the 7 Hole Flatbar FeatureManager.
- 2 Save the model.**
- Click **Isometric**  view.
  - Click **Save** .

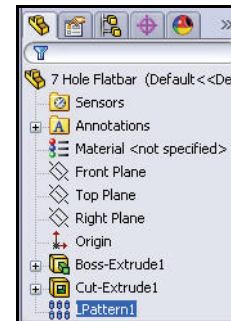

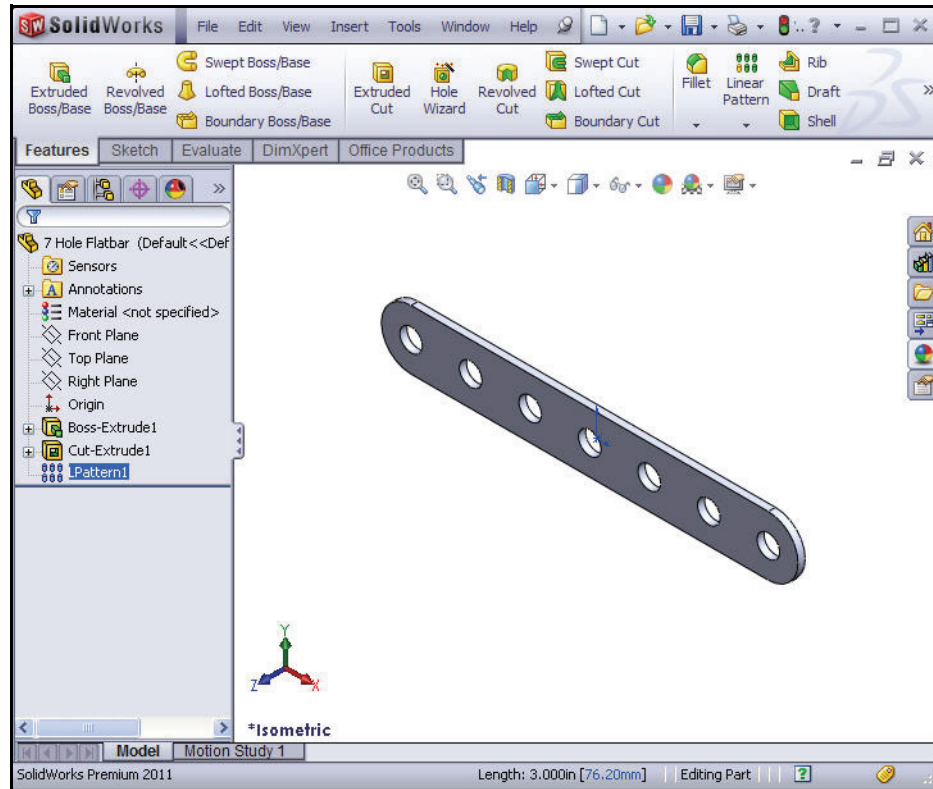

## Inserting a Fillet

A Fillet feature removes sharp edges. Fillets are generally added to the solids, not the sketch. Small corner edge Fillets are grouped together.

### 1 Insert a Fillet feature.

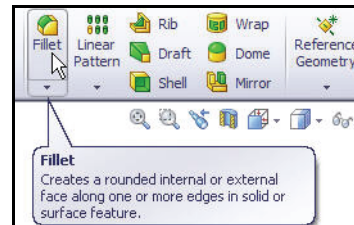
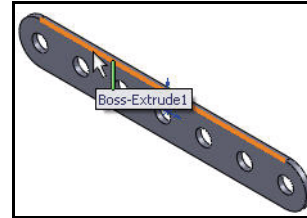

- Click the **front top edge** of the Boss-Extrude1 feature as illustrated.
- Click the **Fillet**  Features tool. The Fillet PropertyManager is displayed.

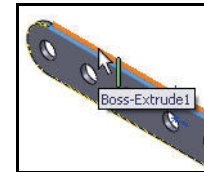

- Click the **Manual** tab. The Fillet PropertyManager is displayed. Edge<1> is displayed in the Edges, Faces, Features, and Loops box.
- Click the **Constant radius** box.
- Click the **back top edge** of the Boss-Extrude1 feature. Edge<2> is displayed in the Edges, Faces, Features, and Loops box.



## Modeling the Trebuchet

- Enter **.010**[.25] for Radius.
  - Click **OK**  from the Fillet PropertyManager. Fillet1 is displayed.
- 2 Fit the model to the Graphics window.**
- Press the **f** key.
- 3 Save the model.**
- Click **Save** .

## SolidWorks

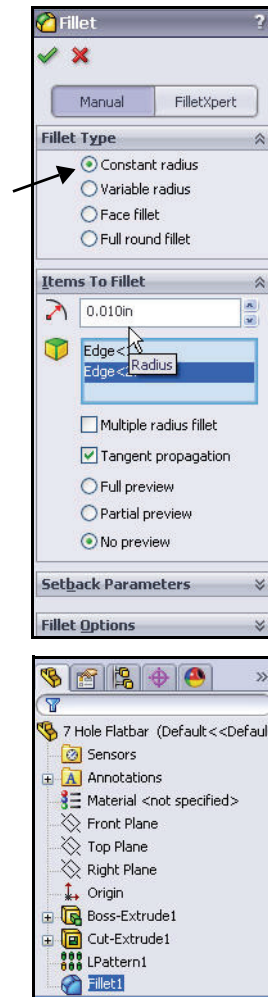

## Applying Material to the 7 Hole Flatbar

- 1 **Apply material to the 7 Hole Flatbar.**
  - Right-click **Material** from the 7 Hole Flatbar FeatureManager.
  - Click **Edit Material**. The Material dialog box is displayed.
  - **Expand** the Steel category.
  - Click **AISI 304**. View the material properties.
  - Click **Apply**.
  - Click **Close**.

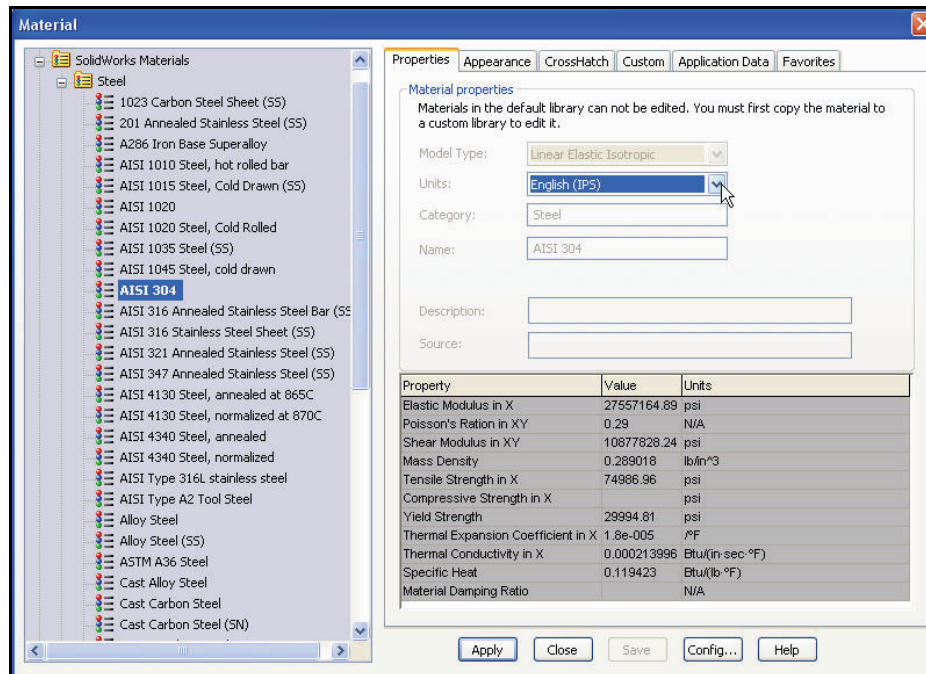
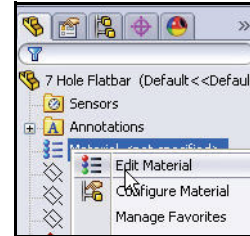

## 2 Save the model.

- Click **Save** .

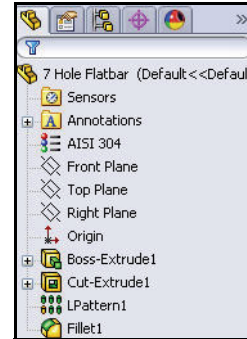

## Creating the Ball Weight

### 1 Create the Ball Weight.

- Click **New**  from the Menu bar toolbar. The Templates tab is the default tab. Part is the default template from the New SolidWorks Document dialog box.
- Click **OK**.

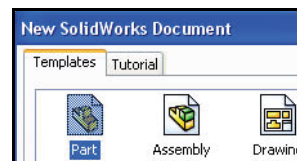

### 2 Save the part.

- Click **Save As** from the Menu bar Consolidated toolbar.
- Select the Save in folder, **SolidWorks-Trebuchet**.
- Select **Part** from Save as type.
- Enter **Ball Weight** for File name.
- Click **Save**. The extension, \*.sldprt is added automatically. The Ball Weight FeatureManager is displayed.

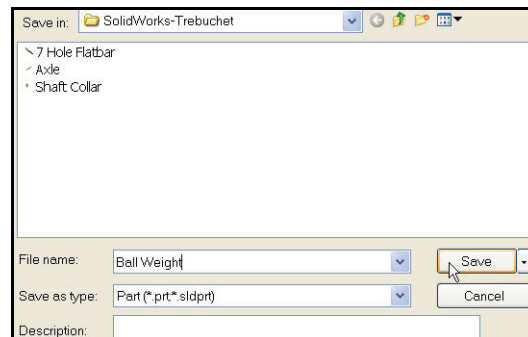

### 3 Set Drafting Standard.

- Click **Options** , **Document Properties** tab from the Menu bar toolbar. The Document Properties - Drafting Standard dialog box is displayed.

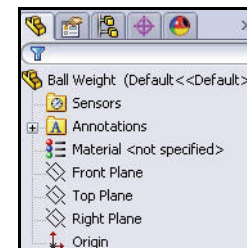

- Select **ANSI** from the drop-down menu for Drafting Standard.

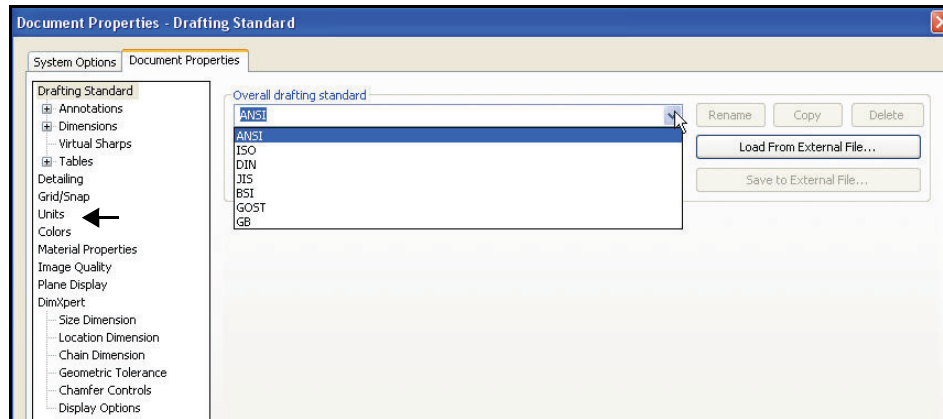

**4 Set unit system and length.**

- Click **Units**.
- Click **IPS** (inch, pound, second) for Unit system.
- Select **.123** for Length unit decimal place.
- Select **None** for Angle decimal place.
- Select **millimeters** for Dual Dimension Length.

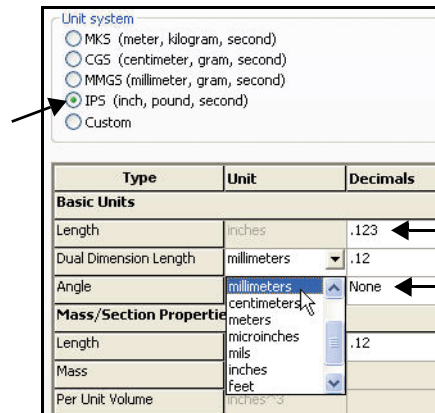

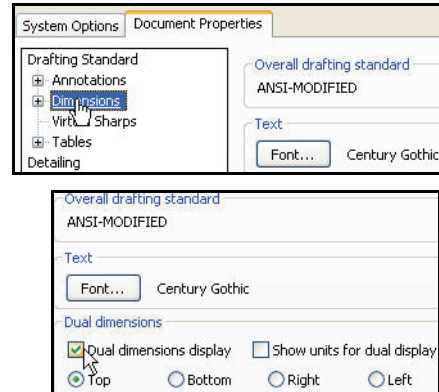

- 5 **Set dual unit display.**
  - Click **Dimensions** from the Document Properties dialog box.
  - Check the **Dual dimensions display** box.
- 6 **Set System options.**
  - Click **OK** from the Document Properties-Dimensions dialog box.

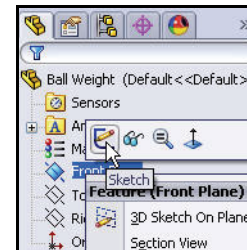

- 7 **Select the Sketch plane.**
  - Right-click **Front Plane** from the Ball Weight FeatureManager. Front Plane is highlighted.



- 8 **Sketch a circle.**
  - Click **Sketch**  from the Context toolbar.
  - Click the **Circle**  Sketch tool. The cursor displays the Circle feedback symbol.
  - Click the **Origin** of the circle. The cursor displays the Coincident to point feedback symbol.
  - Drag the **Mouse pointer** to the right of the Origin.
  - Click a **position** to create the circle.
- 9 **Add a dimension.**

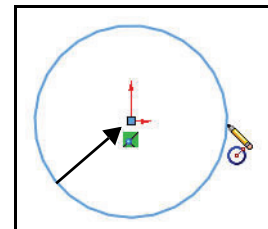

- Click the **Smart Dimension**  Sketch tool.
- Click the **circumference** of the circle.
- Click a **position** diagonally above the circle in the Graphics window.

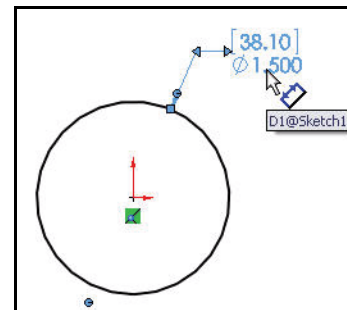

## SolidWorks

## Modeling the Trebuchet

- Enter **1.500**[38.1] in the Modify box.
- Click the  button in the Modify box.

### 10 Sketch a centerline.

- Click the **Centerline**  Sketch tool from the Consolidated line toolbar. The Insert Line PropertyManager is displayed.
- Click the **top centerpoint** of the circle as illustrated.

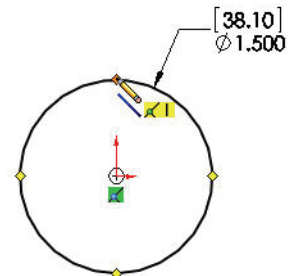
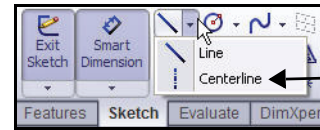

- Sketch a **vertical centerline** from the top centerpoint of the circle to the bottom centerpoint of the circle.
- Click the **bottom center** of the circle to end the centerline.

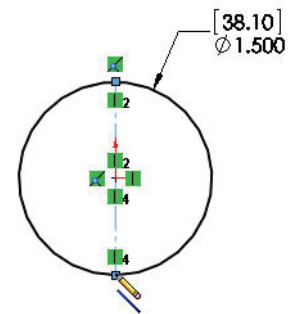

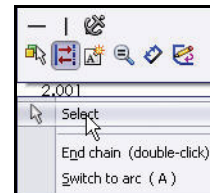

### 11 Deselect the Centerline Sketch tool.

- Right-click **Select**.



### 12 Trim the left side of the circle.

- Click the **Trim Entities**  Sketch tool. The Trim PropertyManager is displayed.
- Click the **Power trim**  option.
- Click a **point** to the left of the left side of the circle.
- Drag the mouse to **intersect** the left side. The left side of the circle is removed.

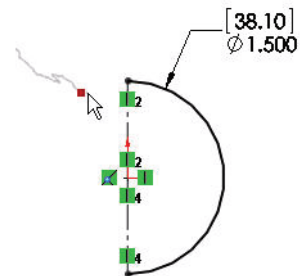

- Click **OK**  from the Trim PropertyManager.

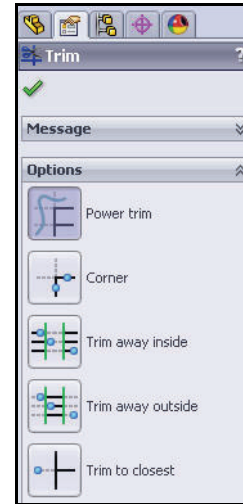

**13 Sketch a line.**

- Click the **line**  Sketch tool.
- Click the **top centerpoint** of the circle.

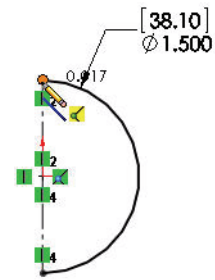
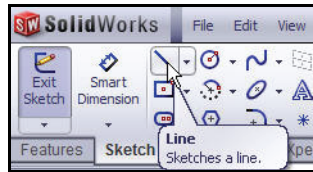

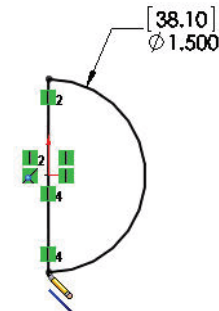

- Sketch a **vertical line** from the top of the circle to the bottom of the circle.
- Click the **bottom centerpoint** to end the line.

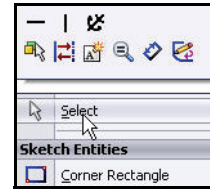

**14 Deselect the Line Sketch tool.**

- Right-click **Select**.

**15 Insert a Revolved Boss/Base feature.**

- Click the **Features** tab from the CommandManager.
- Click the **Revolved Boss/Base**  Features tool. The Revolve PropertyManager is displayed. Line1 is selected in the Revolve Parameters box. Accept the defaults.

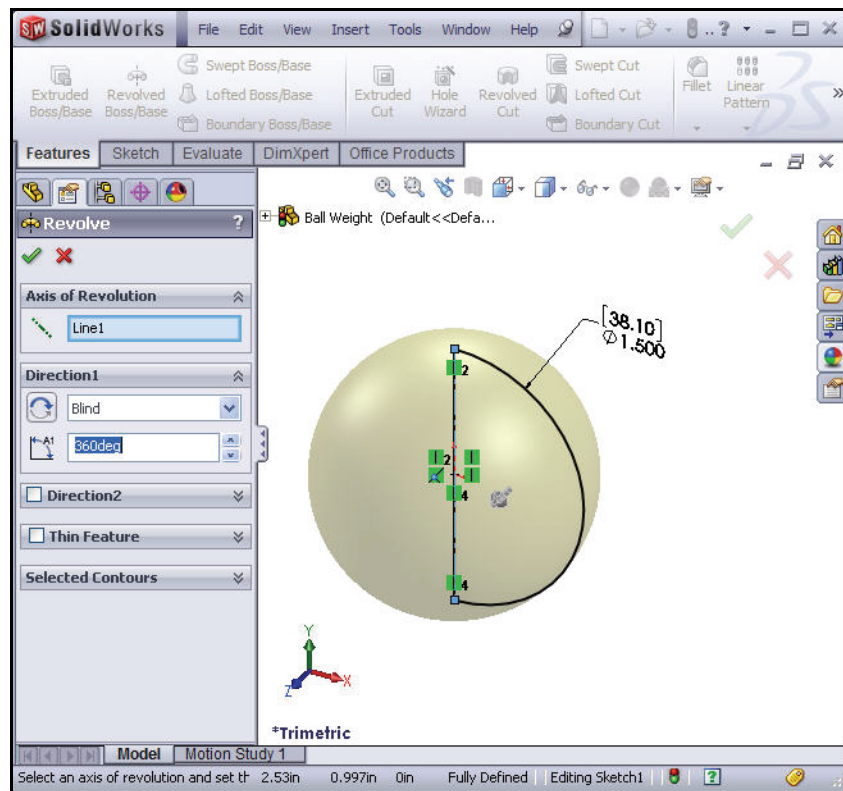
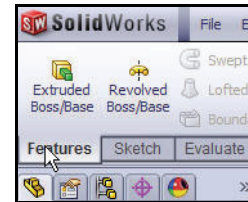

## Modeling the Trebuchet

## SolidWorks

- Click **OK**  from the Revolve PropertyManager. Revolve1 is displayed in the Ball Weight FeatureManager.



### 16 Save the model.

- Click **Save** .

### 17 Select the Sketch plane.

- Right-click **Top Plane** from the Ball Weight FeatureManager. Top Plane is highlighted in the FeatureManager.

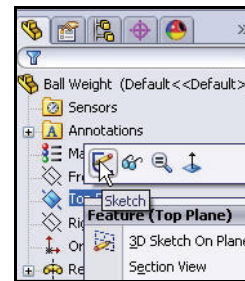
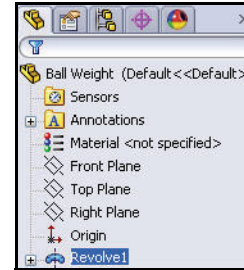

### 18 Create a sketch.

- Click **Sketch**  from the Context toolbar.
- Click the **Circle**  Sketch tool.
- Click the **Origin** of the circle.
- Drag the **mouse pointer** directly to the right of the Origin.
- Click a **position** to create the circle as illustrated.

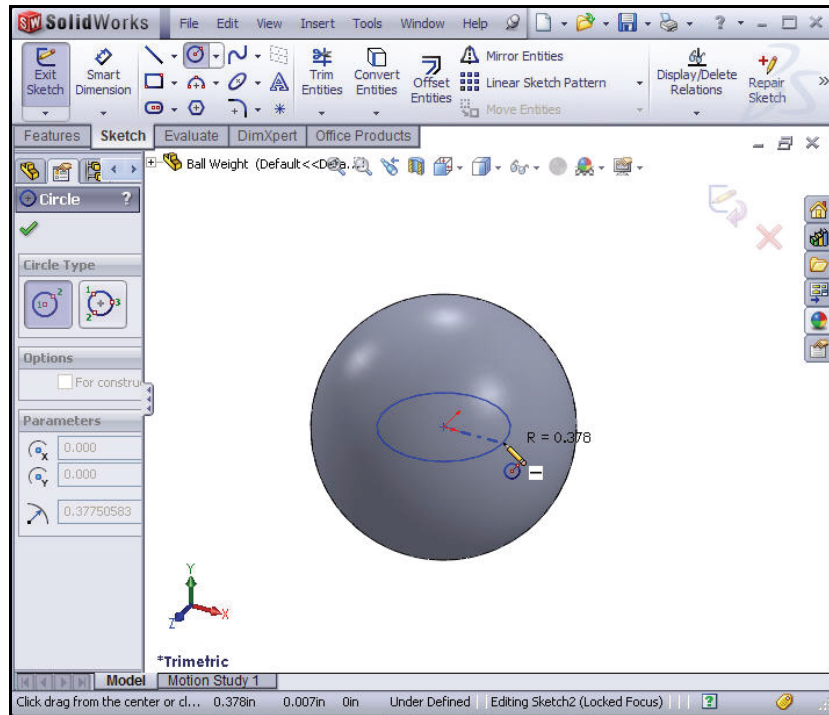



### 19 Add a dimension.

- Click the **Smart Dimension**  Sketch tool.
- Click the **circumference** of the circle.
- Click a **position** diagonally above the circle in the Graphics window.
- Enter **.124**[3.15] in the Modify box.
- Click the  button in the Modify box.

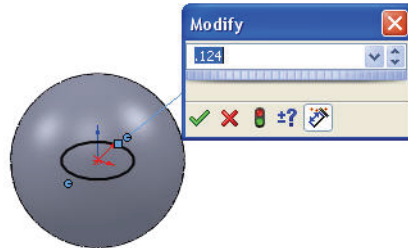

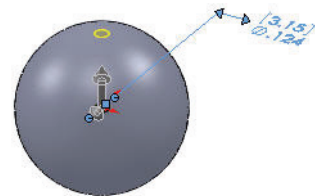

### 20 Fit the model to the Graphics window.

- Press the **f** key.



**21 Insert an Extruded Cut feature.**

- Click **Isometric**  view.
- Click the **Features** tab from the CommandManager.
- Click the **Extruded Cut**  Features tool. The Cut-Extrude PropertyManager is displayed.
- Select **Through All** for End Condition in Direction 1. The Through All End Condition removes material from the Top Plane through the Revolve1 feature.
- Click the **Reverse Direction** button. The arrow points upwards.
- Click **OK**  from the Cut-Extrude PropertyManager. Cut-Extrude1 is displayed in the FeatureManager.

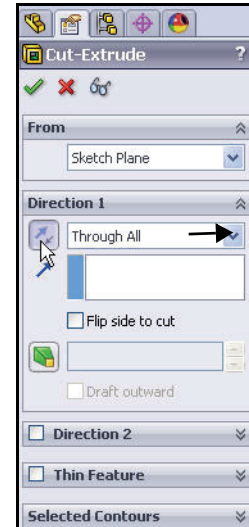
**22 Save the model.**

Click **Save** .

**Applying Material to the Ball Weight****1 Apply material to the Ball Weight.**

- Right-click **Material** from the Ball Weight FeatureManager.
- Click **Edit Material**. The Material dialog box is displayed.

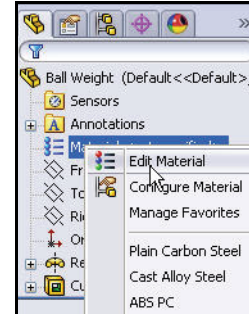

- Expand the Other Metals category.
- Click **Pure Lead**. View the material properties.
- Click **Apply**.
- Click **Close**.

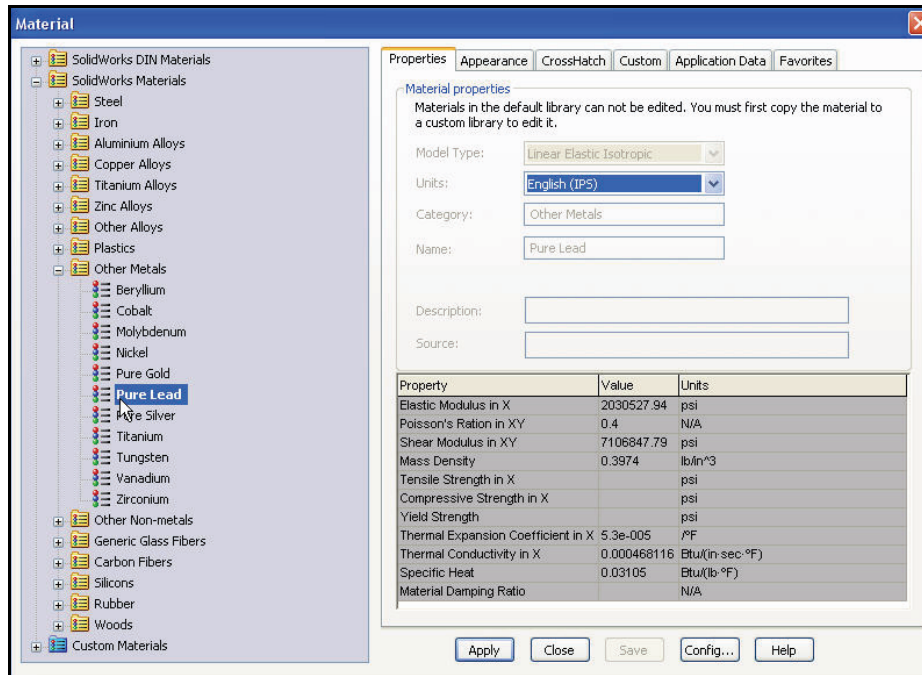

## 2 Save the model.

- Click **Save** .

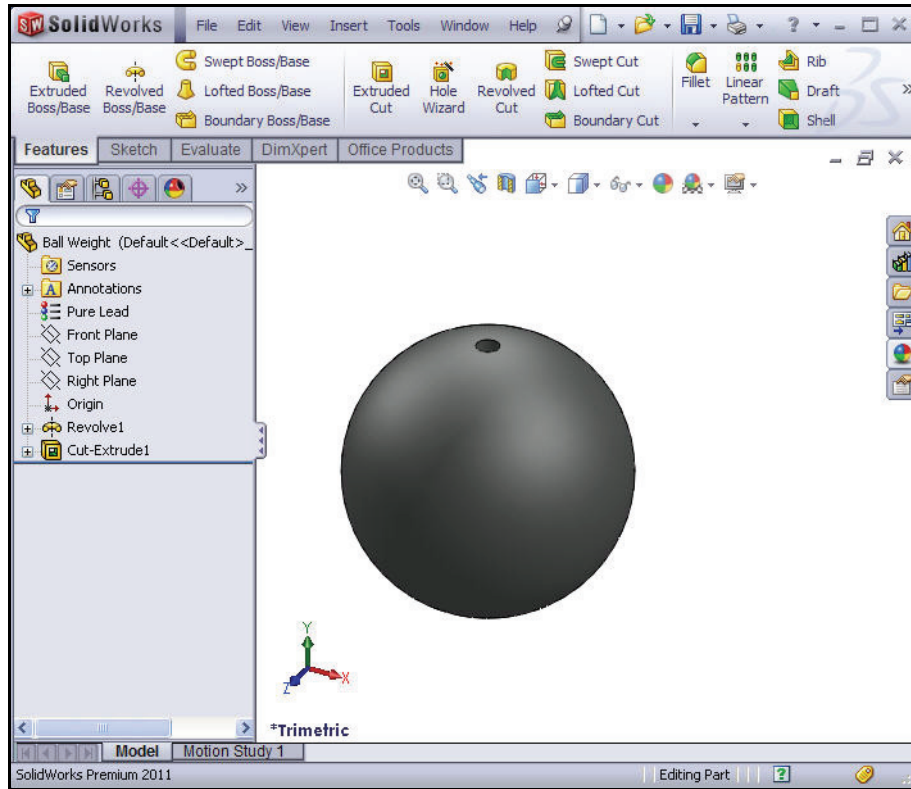

**3 Rename the Cut-Extrude1 feature in the Ball Weight FeatureManager.**

- Click **Cut-Extrude1** from the FeatureManager. Cut-Extrude1 is displayed in blue.
- Click inside the **Cut-Extrude1** blue text box.
- Rename **Cut-Extrude1** to **Hole**.
- Click **inside** the Graphics Window. The Hole feature is utilized in the next lesson.

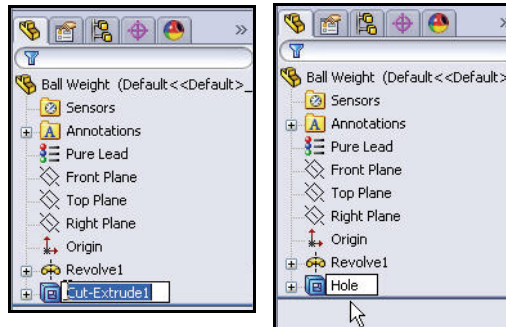

**4 Save the model.**

- Click **Save** .

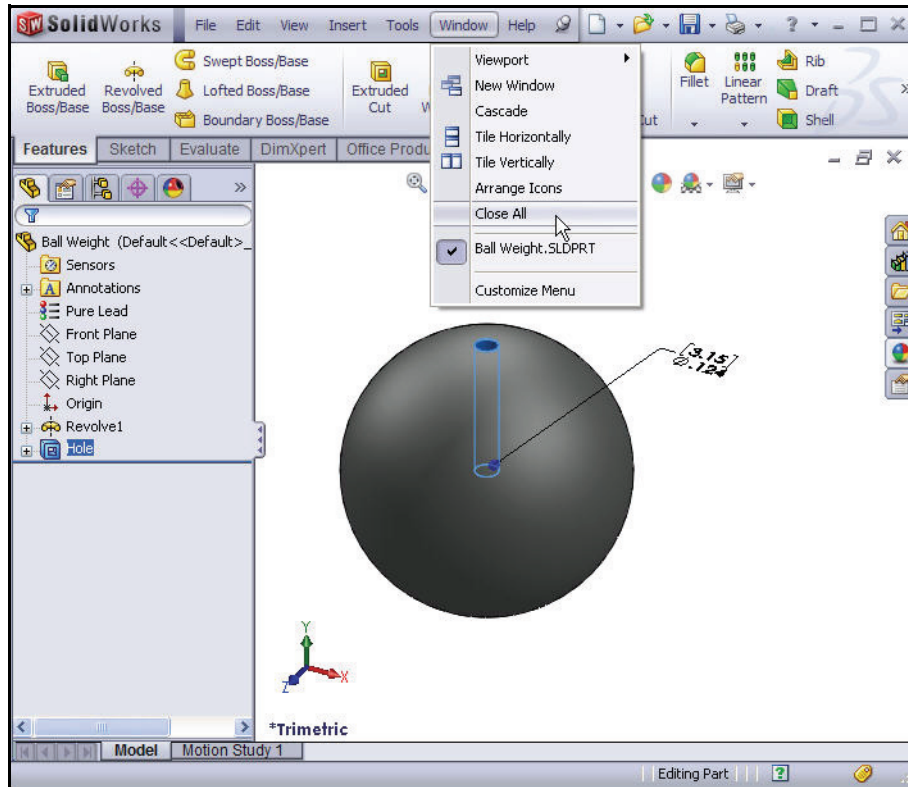
**5 Close all models.**

- Click **Window, Close All** from the Menu bar toolbar.

## Modeling the Trebuchet

## SolidWorks

In this lesson you created the following parts:

- Axle
- Shaft Collar
- 7 Hole Flatbar
- Ball Weight

You utilized the following sketch tools and added and modified dimensions in a sketch:

- Line
- Circle
- Rectangle
- Slot
- Centerline
- Tangent Arc
- Trim Entities

You inserted the following features:

- Extruded Base
- Extruded Boss
- Extruded Cut
- Chamfer
- Fillet
- Revolved Boss/Base

You applied and modified feature dimension, material, renamed a feature and addressed the following relation:

- Equal.

You also used PhotoWorks and saw how easy it is to apply various materials and scenes.

In Lesson 3 you will create assemblies using the parts that were created in this lesson and parts that are supplied.

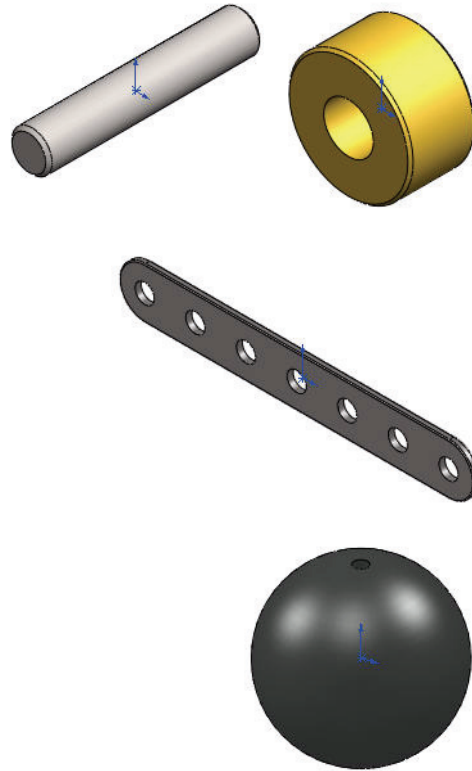

## Lesson 3

# Assembling the Trebuchet

When you complete this Lesson, you will be able to:

- Rename an existing part.
- Create a new assembly.
- Save an assembly.
- Insert a component from Lesson 2.
- Fix and Float a component.
- Insert the following Standard mate types: Concentric, Coincident, Tangent, Parallel, and Distance.
- Move and rotate a component.
- Insert the following components from the SolidWorks Toolbox: Flat Washer Type A, Pan Cross Head Screw, and Machine Screw Nut Hex.
- Hide/Show components from the FeatureManager design tree.

## Assembly

An assembly is a document that contains two or more parts. An assembly inserted into another assembly is called a sub-assembly. A part or sub-assembly inserted into an assembly is called a component. The Trebuchet assembly consists of numerous components. In Lesson 2, you created the following parts:

- Axle.
- Shaft Collar.
- 7 Hole Flatbar.
- Ball Weight.

Establishing the correct component relationship in an assembly requires forethought on component interaction. Mates are geometric relationships that align and fit components in an assembly. Mates remove the degrees of freedom from a component.

## Renaming a Part

### 1 Rename a part.

Rename the Ball Weight part to Weight.

- Click **Open**  from the Menu bar toolbar.
- Double-click **Ball Weight** from the SolidWorks-Trebuchet folder. The Ball Weight is displayed in the Graphics window.
- Click **Save As** from the Consolidated Menu bar toolbar.
- Enter **Weight** for File name.
- Check the **Save as copy** box.
- Click **Save**.

### 2 Close all models.

- Click **Window, Close All** from the Menu bar toolbar.

**Tip:** Do not rename SolidWorks parts in Windows Explorer. Utilize the Save as copy option inside of SolidWorks.

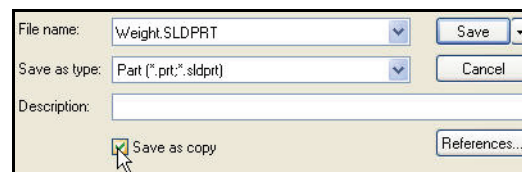
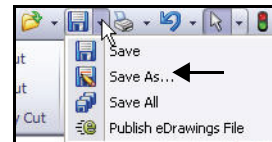
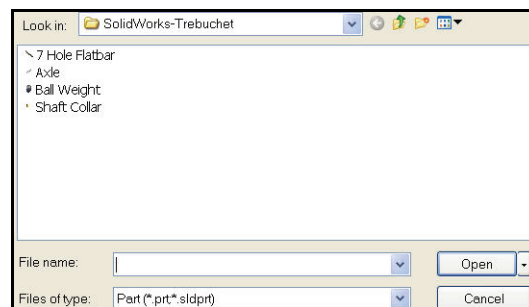

## Creating an Assembly

### 1 Create an assembly.

- Click **New**  from the Menu bar toolbar
- Double-click **Assembly** from the default Templates tab. The Begin Assembly PropertyManager is displayed if the Start command when creating new assembly option is checked.

**Note:** To improve picture clarity in this book, the default planes are deactivated. Click **View**, un-check **Planes** from the Menu bar menu. Click **View**, check **Planes** to display all default planes.

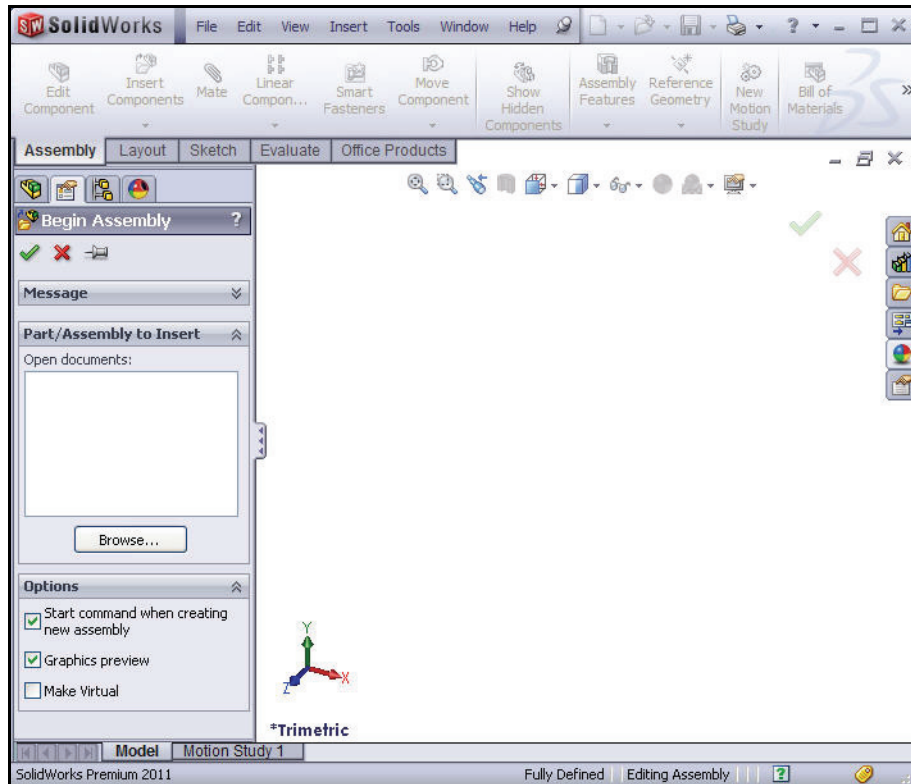
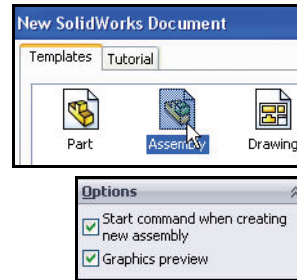

## 2 Insert the Weight component.

- Click **Browse** from the Begin Assembly PropertyManager.
- Select the **SolidWorks-Trebuchet** folder.
- Select **Part** for Files of type.
- Double-click **Weight**. The Weight component is displayed in the Graphics window.

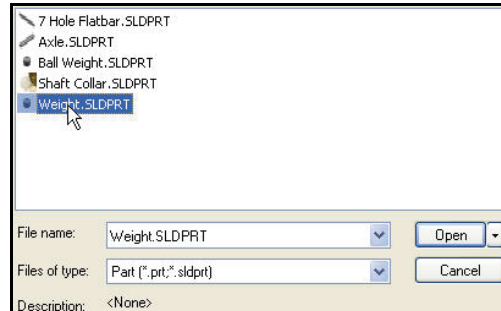

## 3 Fix the component to the Origin.

- Click **OK**  from the Begin Assembly PropertyManager. The component is displayed in the FeatureManager as fixed (f).

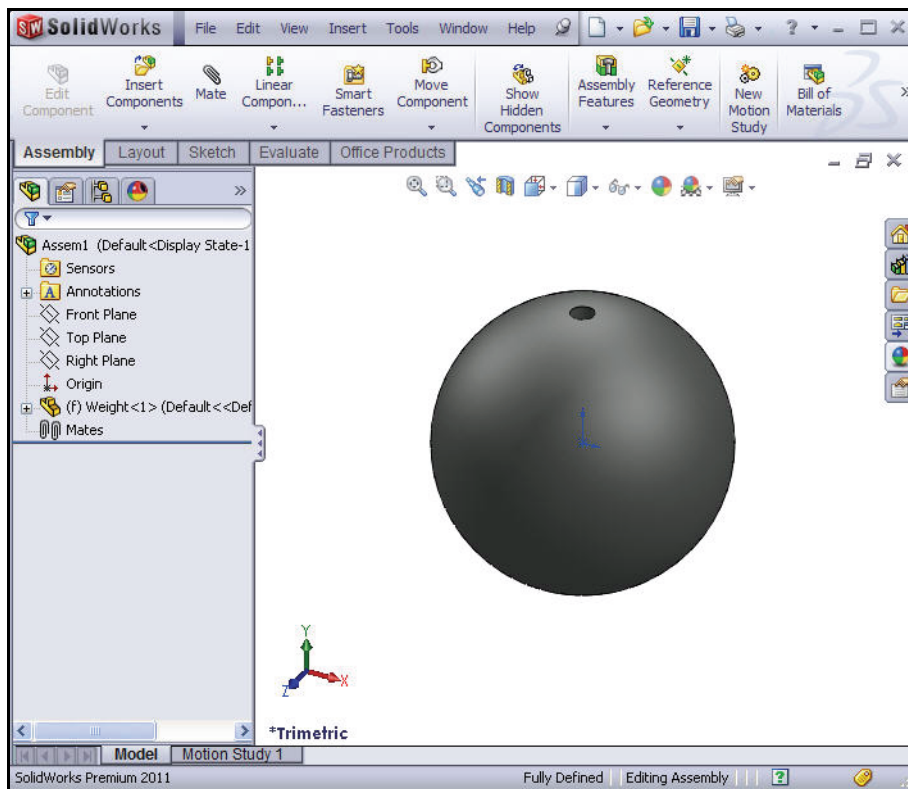

**Note:** The initial component added to the assembly is fixed by default. The fixed component cannot be moved unless you float it.

## SolidWorks

## Assembling the Trebuchet

**Tip:** To remove the fixed state (f), Right-click the component name in the FeatureManager. Click Float. The component is free to move.

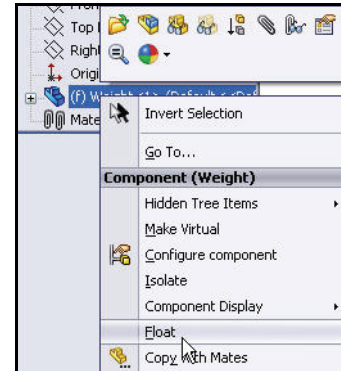

### 4 Save the assembly.

- Click **Save** .
- Enter **Weight-Hook** for File name in the SolidWorks-Trebuchet folder. The Save as type is Assembly (\*.asm;\*.sldasm).
- Click **Save**. The Weight-Hook FeatureManager is displayed.

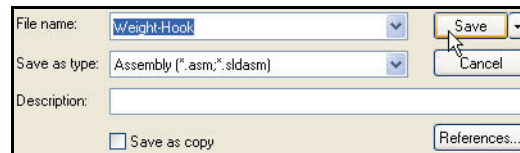

### 5 Set Drafting Standard.

- Click **Options** , **Document Properties** tab from the Menu bar toolbar. The Document Properties - Drafting Standard dialog box is displayed.
- Select **ANSI** from the drop-down menu for Overall drafting standard.

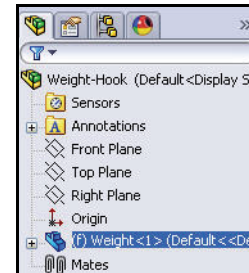

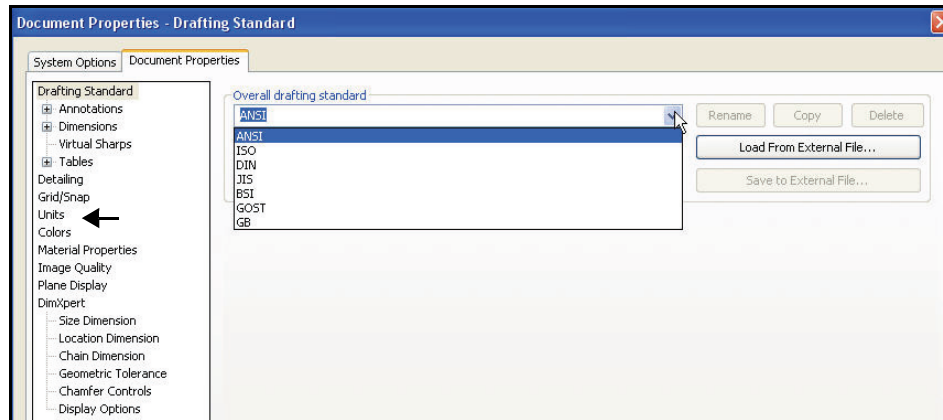

**6 Set unit system and length.**

- Click **Units**.
- Click **IPS** (inch, pound, second) for Unit system.
- Select **.123** for Length unit decimal place.
- Select **None** for Angle decimal place.
- Select **millimeters** for Dual Dimension Length.

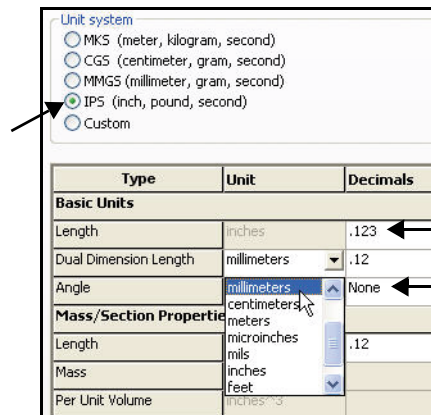

**7 Set dual unit display.**

- Click **Dimensions** from the Document Properties dialog box.
- Check the **Dual dimensions display** box.

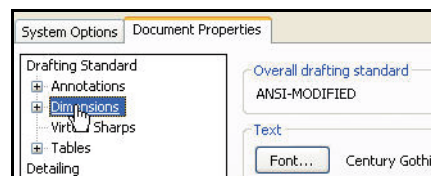

**8 Set System options.**

- Click **OK** from the Document Properties-Dimensions dialog box.

**Note:** All dimensions are displayed in IPS and MMGS units. IPS is the primary unit. Millimeters are displayed in brackets, [ ].

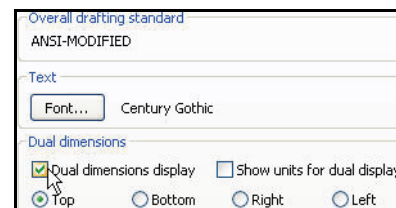

### 9 Insert the Eye Hook component.

- Click the **Assembly** tab from the CommandManager.
- Click the **Insert Components**  tool from the Assembly toolbar. The Insert Component PropertyManager is displayed.
- Click **Browse** from the Insert Component PropertyManager.
- Select the **SolidWorks-Trebuchet** folder.
- Select **Part** for Files of type.
- Double-click **Eye Hook**. The Eye Hook part was created and provided to you for this lesson.
- Click a **position** above the Weight in the Graphics window. The Eye Hook<1> component is displayed in the FeatureManager. The Weight is fixed to the Origin. The Eye Hook part is not fixed.

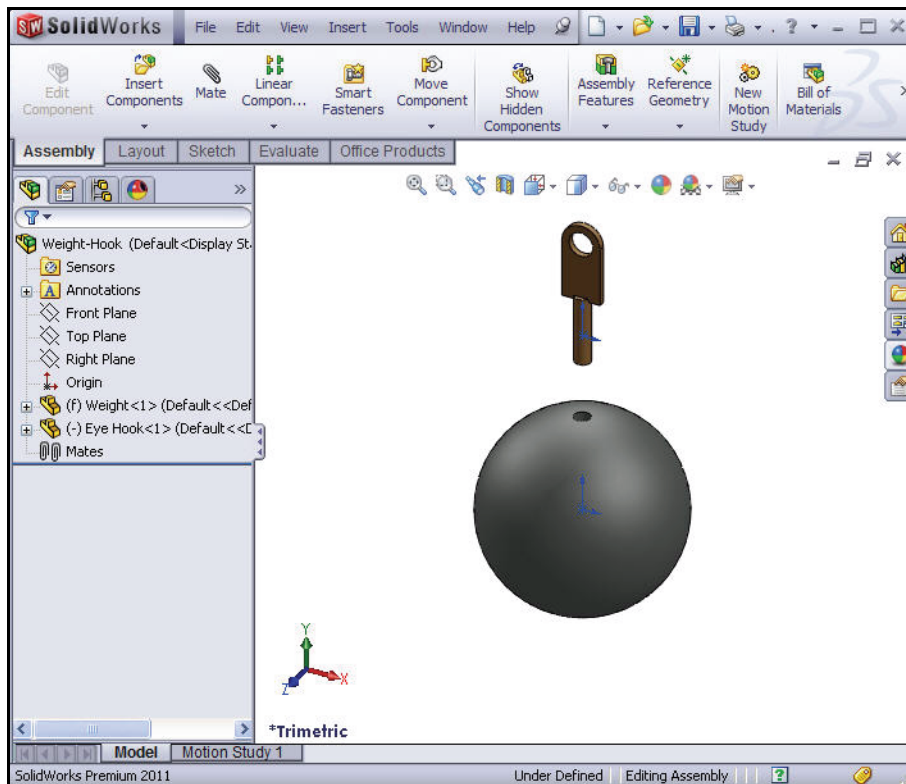
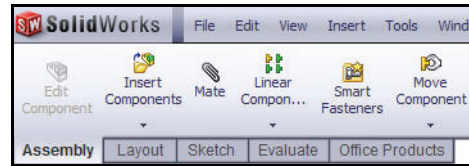

**Note:** To move a non-fixed component, just click and drag the component.

**10 Fit the assembly to the Graphics window.**

- Press the **f** key.

**11 Save the model.**

- Click **Isometric**  view.
- Click **Save** .

## Standard, Advanced and Mechanical Mates

Mates are used to create relationships between components. Mates reflect the physical behavior of a component in an assembly. In this lesson, you will mate the Eye Hook component and the Weight component.

There are three types of mates; Standard, Advanced, and Mechanical mates. You will only use Standard mates in this lesson.

The Mate PropertyManager displays Standard, Advanced, and Mechanical mate types. Components are assembled with various Mate types. The Standard mate types are:

### Standard Mates

- **Coincident:** Positions selected faces, edges, and planes so they share the same infinite line. Position two vertices so they touch.
- **Parallel:** Positions selected geometry so they lie in the same direction and remain a constant distance apart.
- **Perpendicular:** Positions the selected geometry at 90 degrees.
- **Tangent:** Positions the selected items tangent, (at least one selection must be a cylindrical, conical, or spherical face).
- **Concentric:** Positions the selected geometry so that they share the same center point.
- **Lock:** Maintains the position and orientation between two components.
- **Distance:** Positions the selected geometry at a specified distance between them.
- **Angle:** Positions the selected geometry at a specified angle between them.

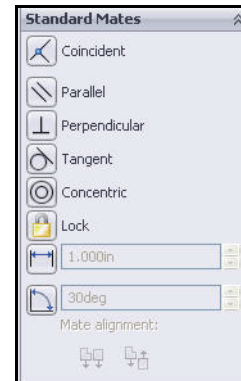

**Note:** The Mate, Show dialog box, displays the Pop-up toolbar during the Mate process.

### Advanced Mates

- **Symmetric:** Positions two selected entities to be symmetric about a plane or planar face.
- **Width:** Centers a tab within the width of a groove.
- **Path Mate:** Constrains a selected point on a component to a path.
- **Linear/Linear Coupler:** Establishes a relationship between the translation for one component and the translation of the other component.
- **Limit:** Provides the ability for components to move within a range of values for distance and angle mates.

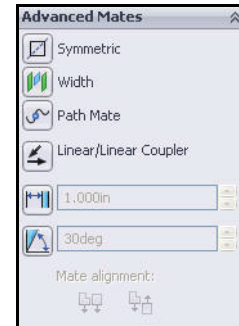

**Note:** You can select many different types of geometry to create a mate:

- Faces
- Planes
- Edges
- Vertices
- Sketch lines and points
- Axes and Origins



### Inserting Mates

#### 1 Insert a Concentric Mate.

Insert a Concentric mate between the cylindrical face of the Eye Hook and the cylindrical face of the Weight Hole.

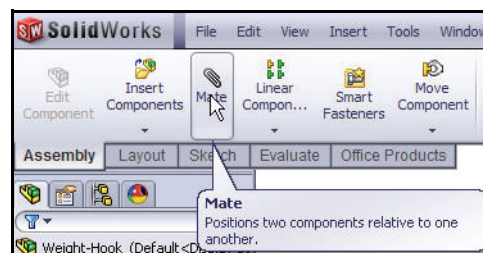
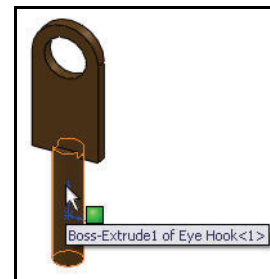
- Click the **cylindrical face** of the Eye Hook. Eye Hook<1> is highlighted in the FeatureManager.
- Click the **Mate**  tool from the Assembly toolbar. The Mate PropertyManager is displayed. Face<1>@Eye Hook-1 is displayed in the Mate Selections box.



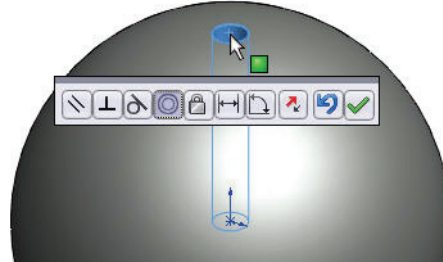

- Click the **Zoom to Area**  tool from the Heads-up View toolbar.
- **Zoom in** on the top of the Weight Hole.
- Click the **Zoom to Area**  tool to deactivate.
- Click the inside **cylindrical face** of the Weight Hole as illustrated.



Face<2>@Weight-1 is displayed in the Mate Selections box. The Mate Pop-up toolbar is displayed.

Concentric is selected by default. The results of the mate is displayed in the Graphics window.



- Click the **Add/Finish Mate**  tool from the Mate Pop-up toolbar.
- Click **OK**  from the Mate PropertyManager.



**Tip:** Position the mouse pointer in the middle of the face to select the entire face. Do not position the mouse pointer near an edge of the face. If the wrong face or edge is selected, perform one of the following actions:

- Right-click in the Graphics window. Click Clear Selections to remove all geometry.
- Utilize the Undo button to begin the Mate command again.

## 2 Fit the assembly to the Graphics window.

- Press the **f** key.

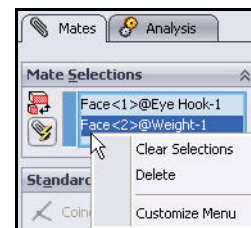

### 3 Insert a Tangent Mate.



Insert a Tangent mate between the top spherical face of the Weight and the bottom flat face of the Eye Hook shoulder.

- Using the middle mouse button, **click** and **rotate** the assembly to view the bottom flat face of the Eye Hook shoulder as illustrated.
- Click the **bottom flat face** of the Eye Hook shoulder as illustrated. Eye Hook<1> is highlighted in the FeatureManager.
- Click the **Mate**  tool from the Assembly toolbar. Face<1>@Eye Hook-1 is displayed in the Mate Selection box.
- Using the middle mouse button, **click** and **rotate** the assembly to view the top spherical face of the Weight.
- Click the **top spherical face** of the Weight as illustrated.

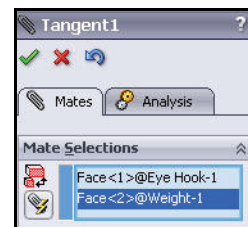
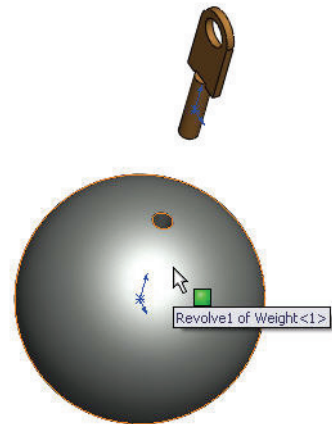
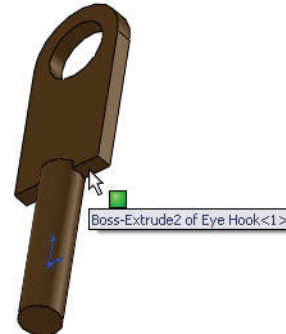
Face<2>@Weight-1 is displayed in the Mate Selections box.



The Mate Pop-up toolbar is displayed. Tangent is selected by default. The results of the Tangent mate is displayed in the Graphics window.

- Click the **Add/Finish Mate**  tool from the Mate Pop-up toolbar.
- Click **OK**  from the Mate PropertyManager.

**4 Deactivate the Origins.**

- Click **View**, un-check **Origins**.

**5 Save the model.**

- Click **Isometric**  view.
- Click **Save** .

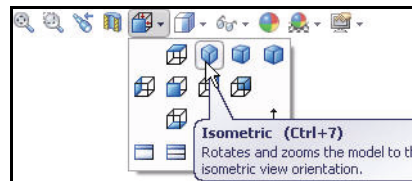
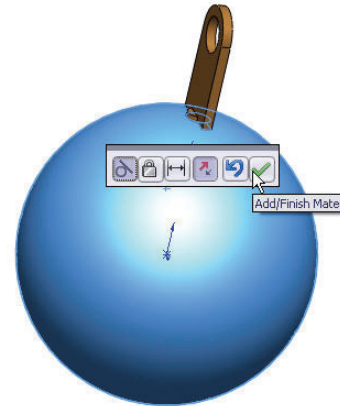

**6 View the Inserted Mates.**

- **Expand** the Mates folder from the Weight-Hook FeatureManager. View the created Mates. You created two Mates: Concentric and Tangent.

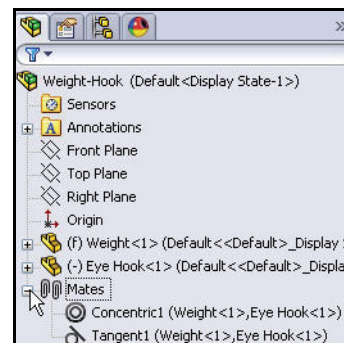

## 7 Insert a Parallel Mate.

Insert a Parallel mate between the Front Plane of the Weight and the flat front face of the Eye Hook.

- **Expand** Weight from the Weight-Hook FeatureManager.
- Click **Front Plane** of the Weight<1> as illustrated.

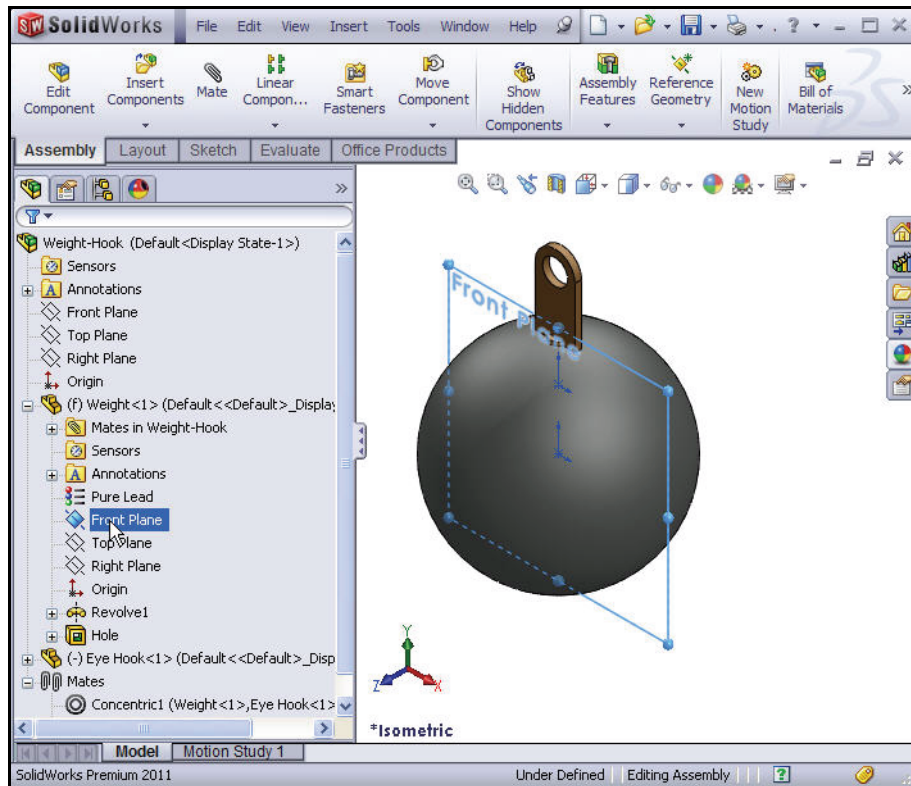

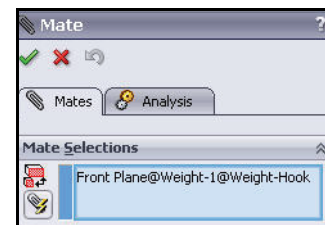

- Click the **Mate**  tool from the Assembly toolbar. Front Plane@Weight-1 is displayed in the Mate Selection box.





## Assembling the Trebuchet

## SolidWorks

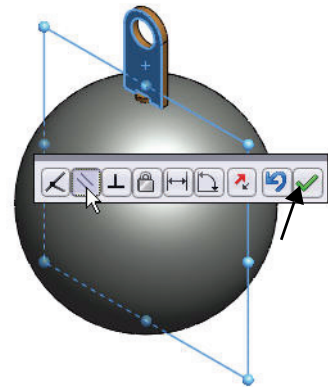
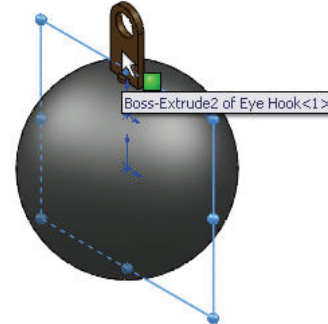
- Click the **flat front face** of the Eye Hook as illustrated. Face<1>@Eye Hook-1 is displayed in the Mate Selection box. A Mate warning is displayed. Select a Mate type
- Click **Parallel** from the Mate Pop-up toolbar. Parallel1 is displayed in the PropertyManager.
- Click the **Add/Finish Mate**  tool from the Mate Pop-up toolbar.
- Click **OK**  from the Mate PropertyManager.



- 8 **View the inserted Mates.**
  - **Expand** the Mates folder from the Weight-Hook FeatureManager. View the created Mates. A Parallel mate is added to the Mates folder.
- 9 **Save the model.**
  - Click **Isometric**  view.
  - Click **Save** .

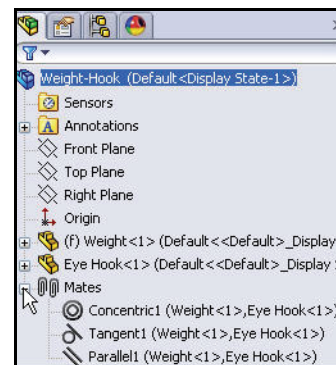

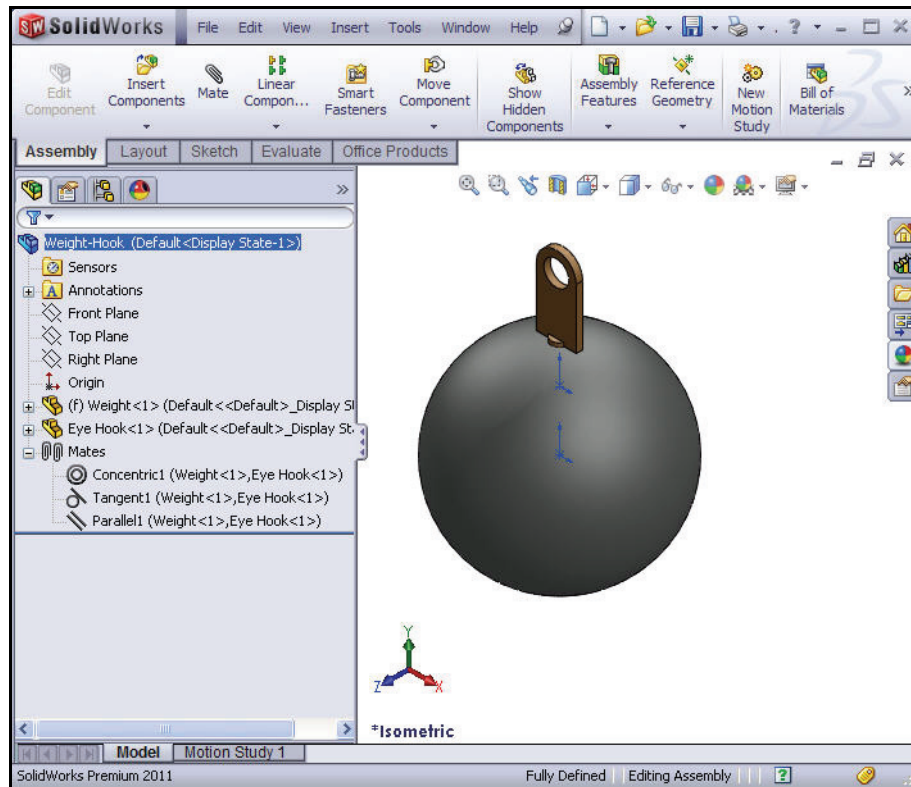

## Creating the Counter Weight Assembly

### 1 Create an assembly.

- Click **New**  from the Menu bar toolbar.
- Double-click **Assembly** from the default Templates tab. The Begin Assembly PropertyManager is displayed.

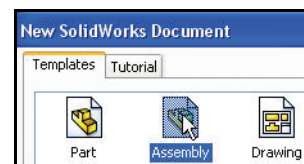

- 2 **Insert the Axle component.**
  - Click **Browse** from the Begin Assembly PropertyManager.
  - Select the **SolidWorks-Trebuchet** folder.
  - Select **Part** for Files of type.
  - Double-click **Axle**. The Axle component is displayed in the Graphics window.
- 3 **Fix the component to the Origin.**
  - Click **OK**  from the Begin Assembly PropertyManager. The component is displayed in the FeatureManager as fixed (f).

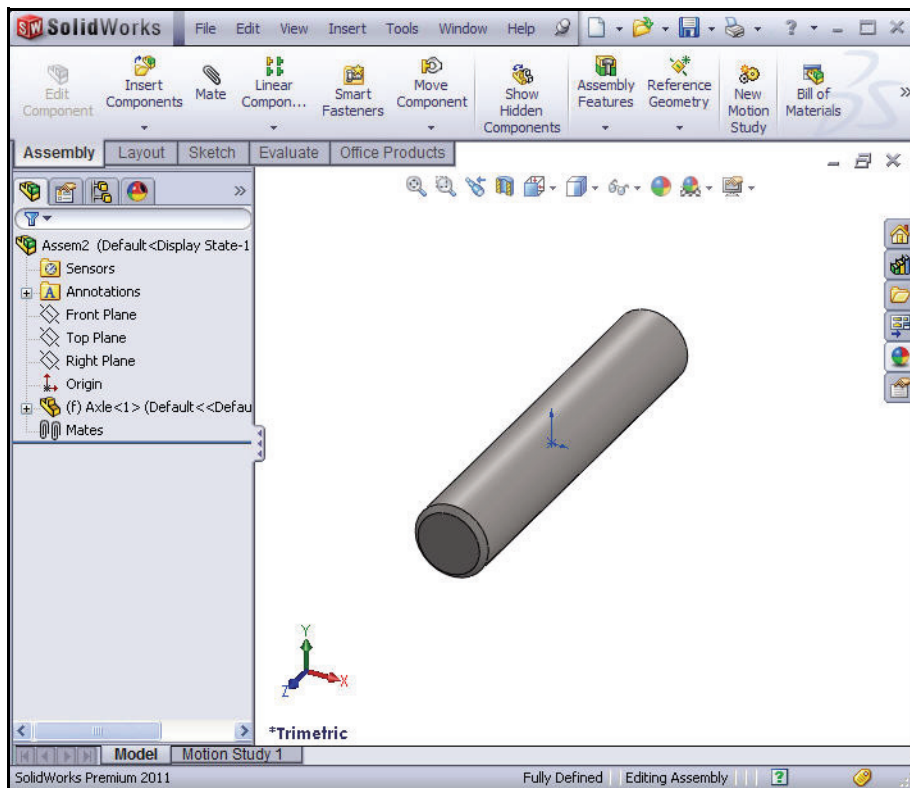
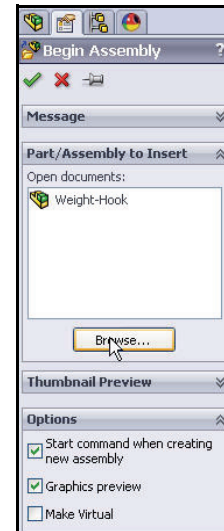

#### 4 Save the Counter Weight assembly.

- Click **Save** .
- Enter **Counter Weight** for File name in the SolidWorks-Trebuchet folder. The Save as type is Assembly (\*.asm,\*.sldasm).
- Click **Save**. The Counter Weight FeatureManager is displayed.

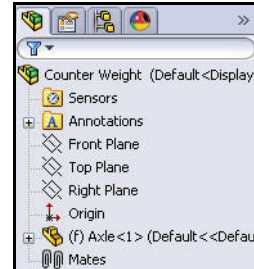

#### 5 Set Drafting Standard.

- Click **Options** , **Document Properties** tab from the Menu bar toolbar. The Document Properties - Drafting Standard dialog box is displayed.
- Select **ANSI** from the drop-down menu for Drafting Standard.

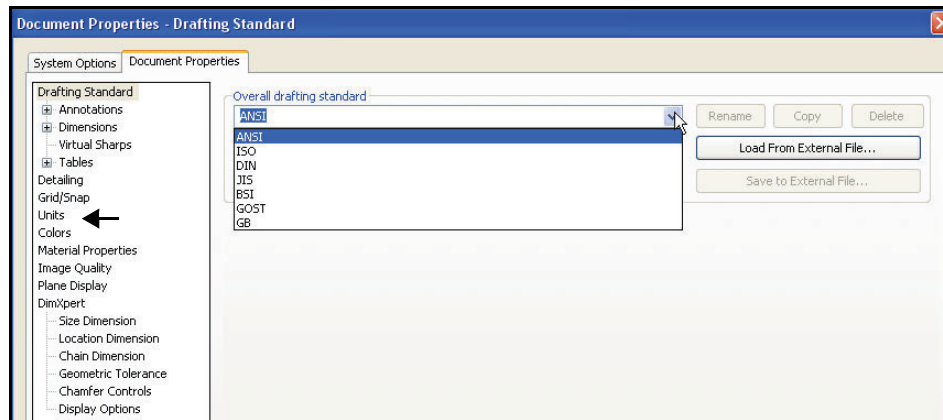

**6 Set unit system and length.**

- Click **Units**.
- Click **IPS** (inch, pound, second) for Unit system.
- Select **.123** for Length unit decimal place.
- Select **None** for Angle decimal place.
- Select **millimeters** for Dual Dimension Length.

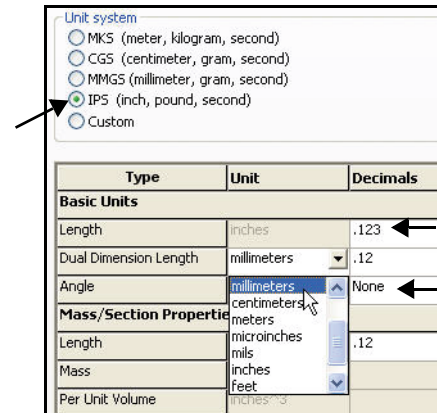
**7 Set dual unit display.**

- Click **Dimensions** from the Document Properties dialog box.
- Check the **Dual dimensions display** box.

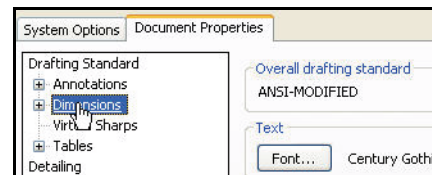
**8 Set System options.**

- Click **OK** from the Document Properties-Dimensions dialog box.

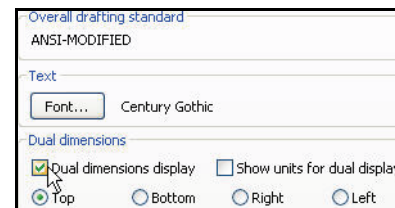
**9 Insert the Flat component.**

- Click the **Insert Components**  tool from the Assembly toolbar. The Insert Component PropertyManager is displayed.
- Click **Browse** from the Insert Component PropertyManager.
- Select the **SolidWorks-Trebuchet** folder.
- Select **Part** for Files of type.



- Double-click **Flat**.
- Click a **position** above the Axle in the Graphics window. The Flat component is displayed in the FeatureManager.

**Note:** The Flat component was created and provided to you.

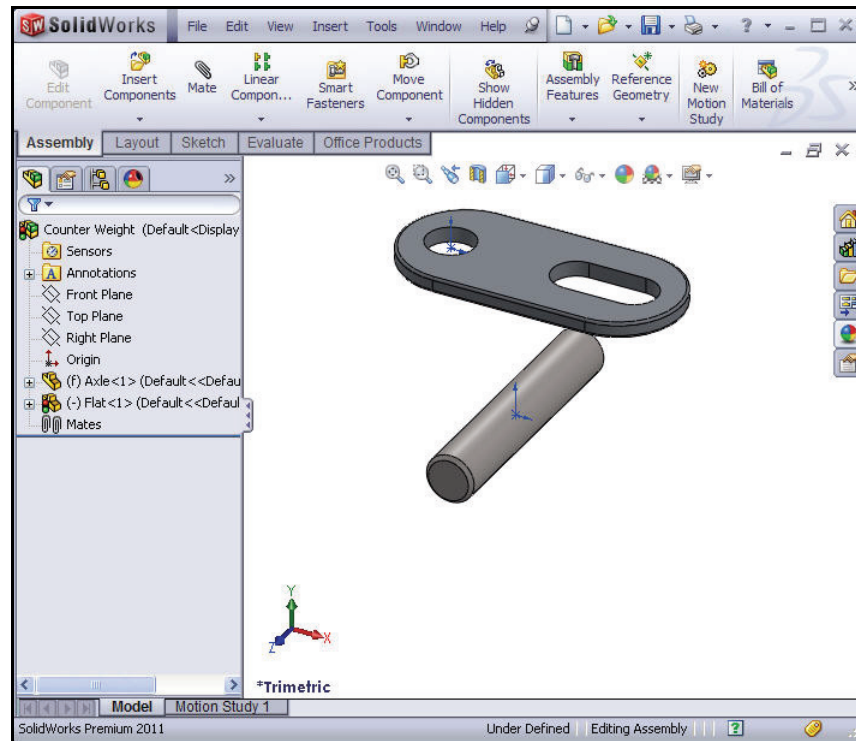

#### 10 Fit the assembly to the Graphics window.

- Press the **f** key.

### Inserting Mates

#### 1 Insert a Concentric Mate.

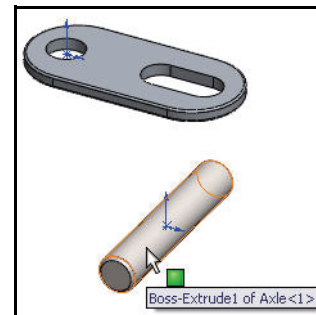

Insert a Concentric mate between the cylindrical face of the Axle and the cylindrical face of the Flat hole component.

- Click the **cylindrical face** of the Axle as illustrated. (f) Axle<1> is highlighted in the FeatureManager.



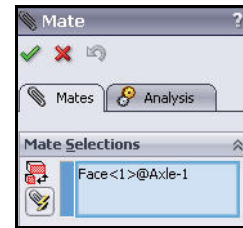

- Click the **Mate**  tool from the Assembly toolbar. Face<1>@Axle-1 is displayed in the Mate Selection box.
- Using the middle mouse button, rotate the **Flat** component for improve visibility of the top small hole.

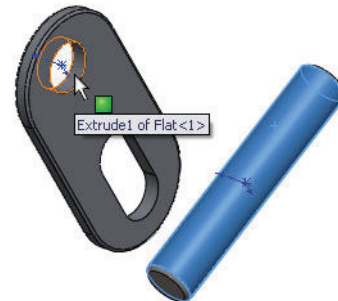

- Click the **Zoom to Area** tool .
- **Zoom in** on the cylindrical face of the Flat top hole.
- Click the **Zoom to Area** tool  to deactivate.
- Click the **cylindrical face** of the Flat top small hole as illustrated. The selected face is displayed in the Mate Selection box. The Mate Pop-up toolbar is displayed.



Coincident is selected by default. The results of the mate is displayed in the Graphics window.

- Click the **Add/Finish Mate**  tool from the Mate Pop-up toolbar.
  - Click **OK**  from the Mate PropertyManager.
- 2 Deactivate the Origins.**
- Click **View**, un-check **Origins**.

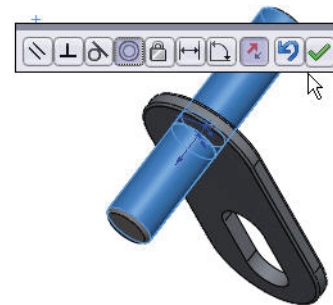

**3 Save the model.**

- Click **Isometric**  view.
- Click **Save** .

**4 Move the Flat component.**

- **Click** and **drag** the Flat component along the Axle as illustrated.

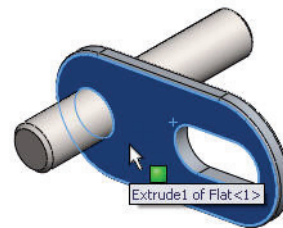
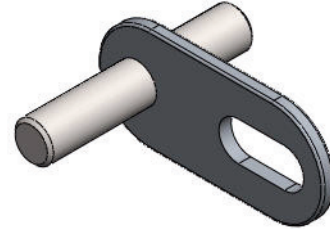
**5 Insert a Distance Mate.**

- Insert a Distance mate between the flat face of the Axle and the flat face of the Flat component.

- Click the front **flat face** of the Axle.

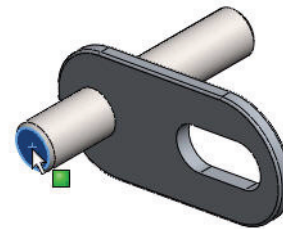

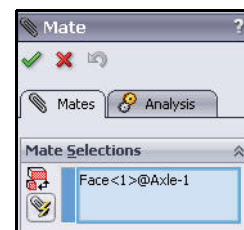

- Click the **Mate**  tool from the Assembly toolbar. Face<1>@Axle-1 is displayed in the Mate Selection box.

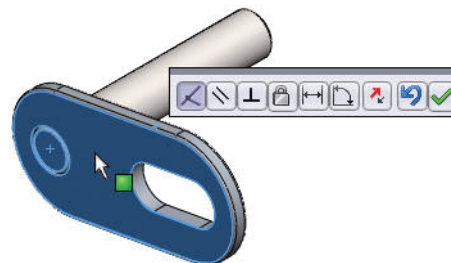

- Click the front **flat face** of the Flat component as illustrated. Face<2>@Flat-1 is displayed in the Mate Selection box. The Mate Pop-up toolbar is displayed.





- Click **Distance** from the Mate Pop-up box.
- Enter **.47**[11.94] for Distance.
- Click the **Add/Finish Mate**  tool from the Mate Pop-up toolbar. The results of the Mate is displayed in the Graphics window.
- Click **OK**  from the Mate PropertyManager.

**Tip:** To center the Flat component on the Axle, Subtract the thickness of the Flat component from the length of the Axle and divide by 2. Equation:  $(1.00\text{in} - .06\text{in})/2 = .47\text{in}$ .

#### 6 Move the Flat component.

- **Click** and **drag** the Flat component. The Flat rotates about the Axle.
- Position the **Flat** below the Axle as illustrated.

#### 7 Save the model.

- Click **Isometric**  view.
- Click the **Rebuild**  tool from the Menu bar toolbar.
- Click **Save** .
- **Expand** the Mates folder to view the created mates.

### Using SolidWorks Toolbox

In a make-buy decision process, a decision is made on which parts to manufacture and which parts to purchase.

In assembly modeling, a decision is made on which parts to design and which parts to obtain from libraries and the World Wide Web.

SolidWorks contains a variety of designed parts in the Design Library.

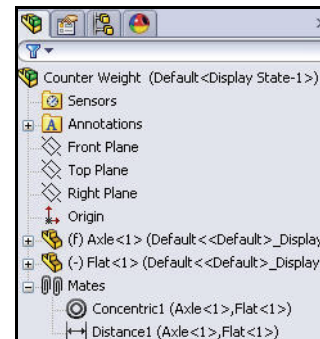
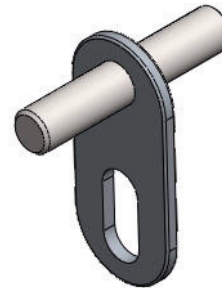
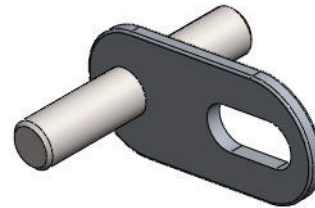
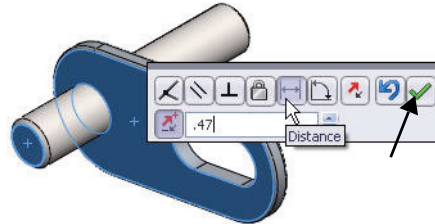



## SolidWorks

## Assembling the Trebuchet

The SolidWorks Toolbox is a library of features based design automation tools for SolidWorks. The Toolbox uses the window's drag and drop functionality with SmartMates. Fasteners are displayed with full thread detail.

- 1 **Insert a Washer from the SolidWorks Toolbox.**
  - Click the **Options** drop-down arrow.
  - Click **Add-Ins** from the Consolidated Menu bar toolbar.
  - Check the **SolidWorks Toolbox** box.
  - Check the **SolidWorks Toolbox Browser** box.
  - Click **OK** from the Add-Ins dialog box.

- Click the **Zoom to Area**  tool.
- **Zoom in** on the upper front arc edge of the Flat component as illustrated.
- Click the **Zoom to Area**  tool to deactivate.

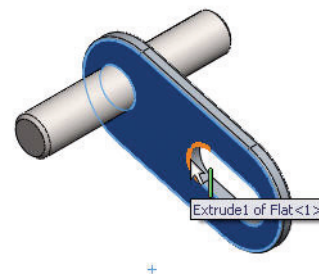
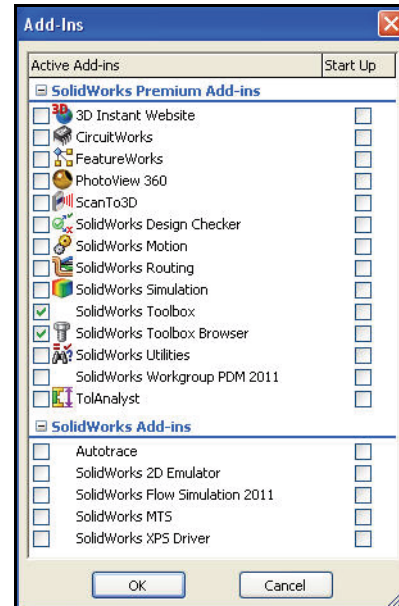
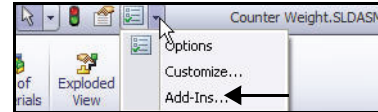

## 2 Display the SolidWorks Design Library.

**Note:** If required, click **View, Task Pane** from the Menu bar menu.

- Click the **Design Library**  tab from the Task Pane.
- **Expand** the Toolbox folder.
- **Expand** the Ansi Inch folder. **Note:** You would expand Ansi Metric if you were using the MMGS unit system.
- **Expand** the Washers folder.
- Click the **Plain Washers Type A** folder. Various types of Machine washers are displayed.

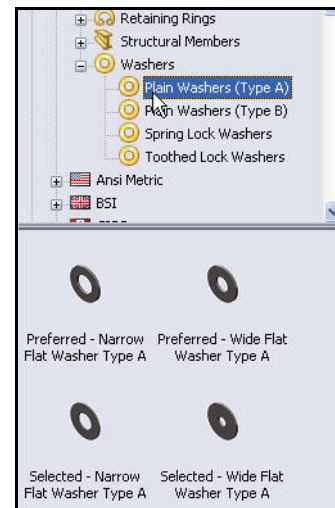
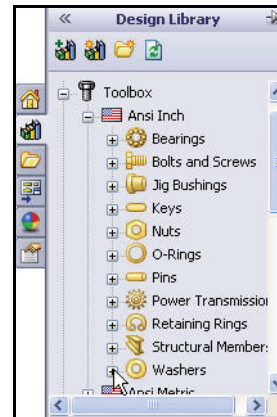

- **Drag and drop** the Preferred-Narrow Flat Washer Type A into the Graphics window on the **upper arc edge** of the Flat component as illustrated. The Preferred - Narrow Flat Washer Type A PropertyManager is displayed.

**Note:** The washer in your picture will be displayed larger.

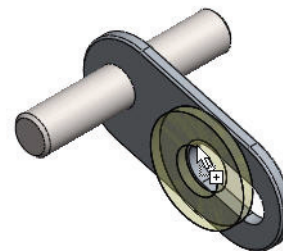

## SolidWorks

## Assembling the Trebuchet

- Select **10** for size. View the PropertyManager. Accept the default settings.
- Click **OK** .

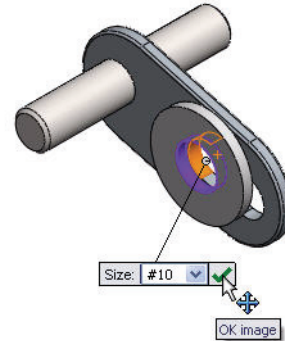

- Click **Cancel**  from the Insert Components PropertyManager.
- 3 Save the model.**

- Click **Isometric**  view.
- Click **Save** .

View the Flat Washer Type A Narrow part, FW 0.19 in the FeatureManager.

**4 View the Mates.**

- **Expand** the Mates folder from the FeatureManager. A Concentric and a Coincident mate was inserted.

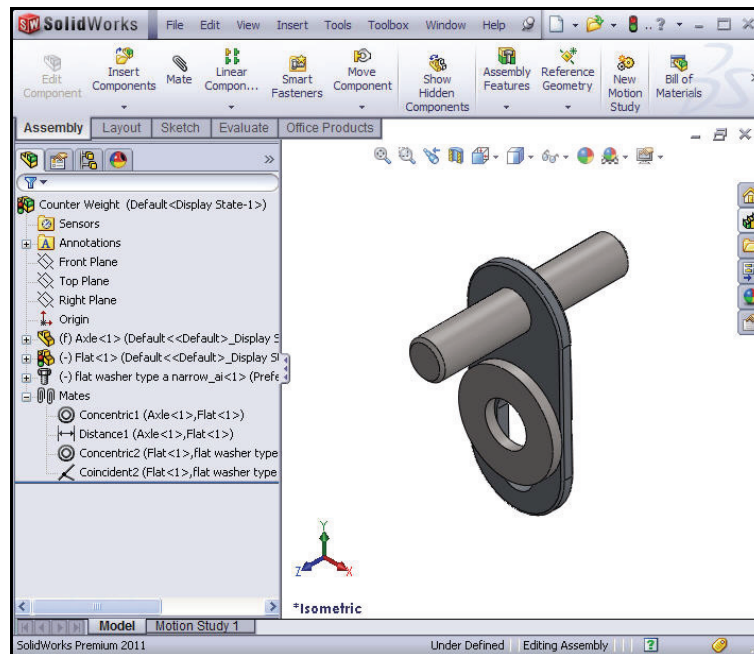
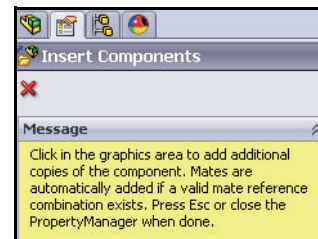

5 Insert a Pan Cross Head screw from the SolidWorks Toolbox.

- Click the **Design Library**  tab.
- **Expand** the Toolbox folder.
- **Expand** the Ansi Inch folder.



- **Expand** the Bolts and Screws folder.
- Click the **Machine Screws** folder. Various types of Machine Screws are displayed.

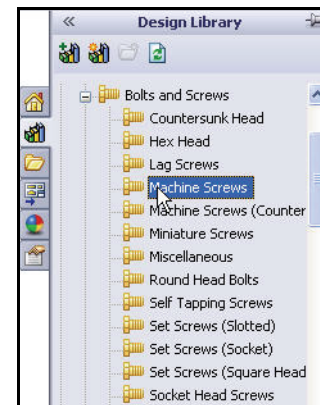

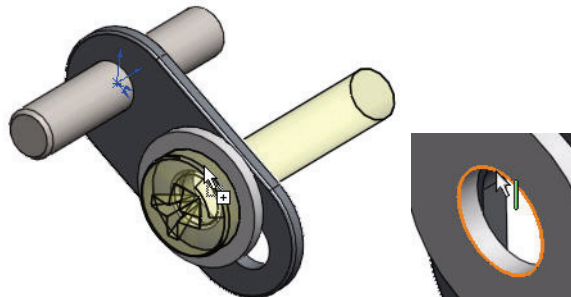

- **Drag and drop** the Pan Cross Head Screw into the Graphics window on the **edge** of the Washer as illustrated. The Pan Cross Head PropertyManager is displayed.



## SolidWorks

- Select **10-24** for size.
- Select **1** for Length. Accept the default settings.
- Click **OK**  from the Pan Cross Head PropertyManager.

- Click **Cancel**  from the Insert Components PropertyManager.
- 6 Save the model.**
- Click **Isometric**  view.
  - Click **Save** . View the Pan Cross Head part, CR-PHMS from the FeatureManager.

## Assembling the Trebuchet

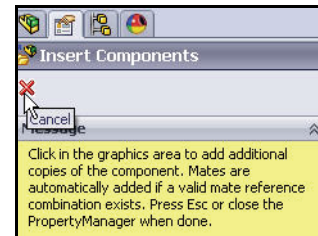
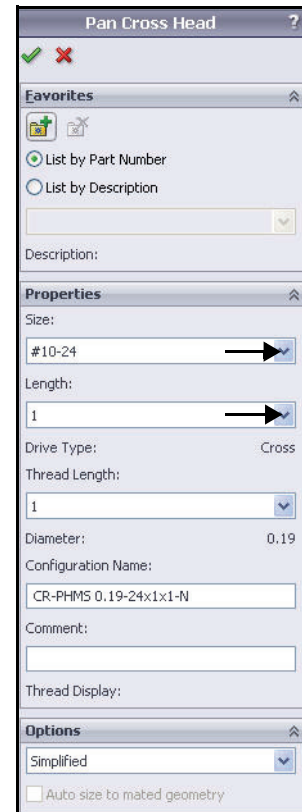

## 7 View the Mates.

- Expand the Mates folder from the FeatureManger. A Concentric and a Coincident mate was inserted.

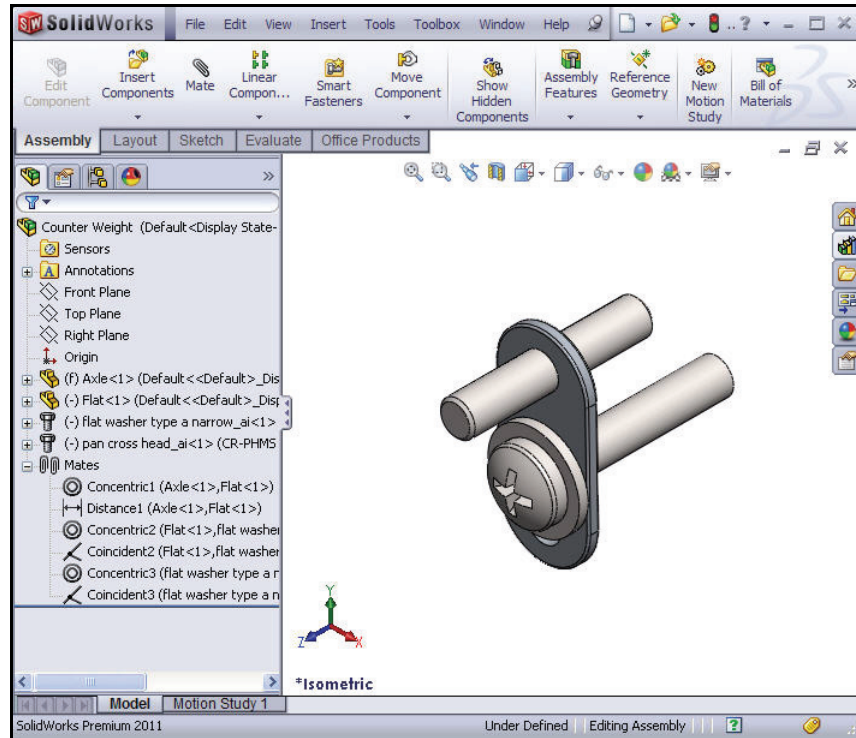

## Inserting the Weight-Hook Assembly

### 1 Insert the Weight-Hook assembly.

- Click the **Insert Components**  tool from the Assembly toolbar. The Insert Component PropertyManager is displayed.
- Click **Browse** from the Insert Component PropertyManager.
- Select the **SolidWorks-Trebuchet** folder.
- Select **Assembly** for Files of type.
- Double-click **Weight Hook**.
- Click a **position** above the Counter Weight assembly in the Graphics window.

**Note:** If Weight-Hook is an active document, double-click Weight-Hook in the Open documents box to open the assembly.

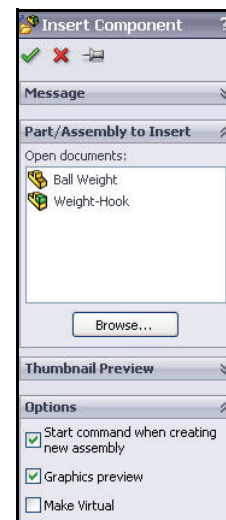

The Weight Hook sub-assembly is displayed in the Counter Weight FeatureManager.

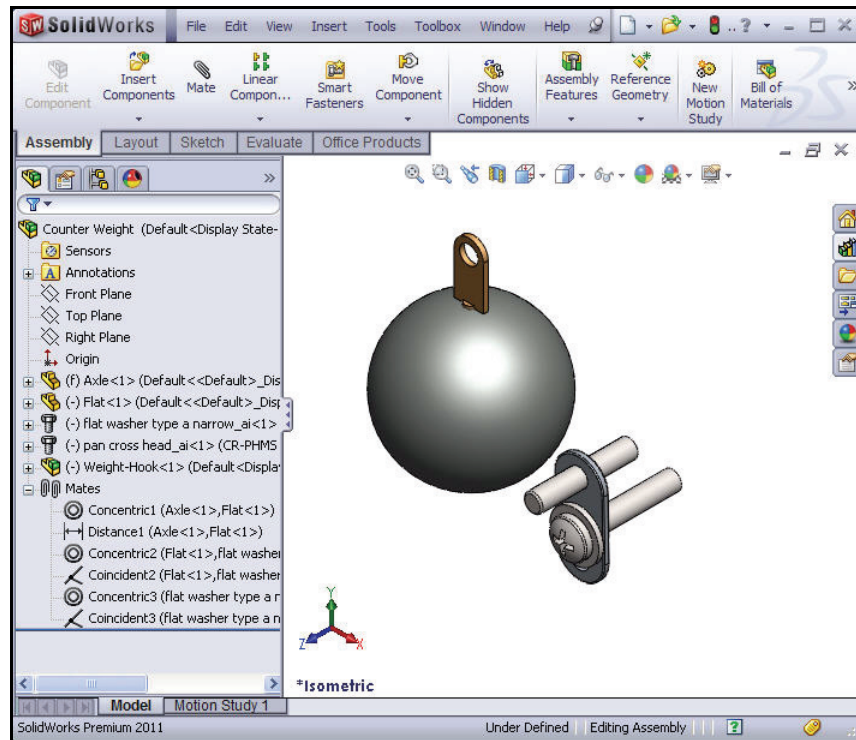

## Inserting Mates

### 1 Create a Concentric Mate.

Create a Concentric mate between the cylindrical face of the Pan Cross Head shaft and the Eye Hook cylindrical face.

- Click the **cylindrical face** of the Pan Cross Head shaft as illustrated.

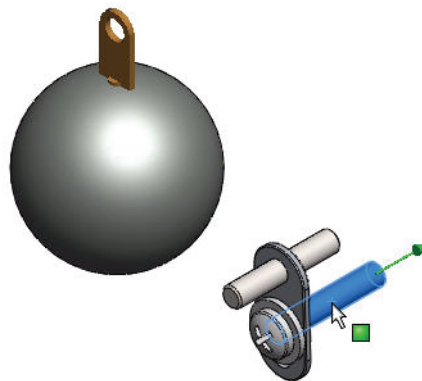



## Assembling the Trebuchet

## SolidWorks

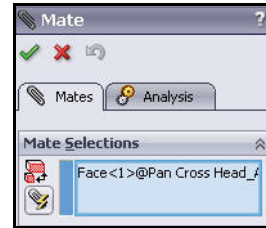
- Click the **Mate**  tool from the Assembly toolbar. Face<1>@Pan Cross Head is displayed in the Mate Selection box.



- Click the **Zoom to Area**  tool.
- **Zoom in** on the Eye Hook cylindrical face.
- Click the **Zoom to Area**  tool to deactivate.
- Click the **inside cylindrical face** of the Eye Hook as illustrated.



Face<2>@Weight-Hook is displayed in the Mate Selection box. The Mate Pop-up toolbar is displayed. Concentric is selected by default. The results of the mate is displayed in the Graphics window.



- Click the **Add/Finish Mate**  tool from the Mate Pop-up toolbar.

### 2 Create a Coincident Mate.

Create a Coincident mate between the front face of the Flat part and the back face of the Eye Hook. Currently the Weight-Hook rotates about the Axles.

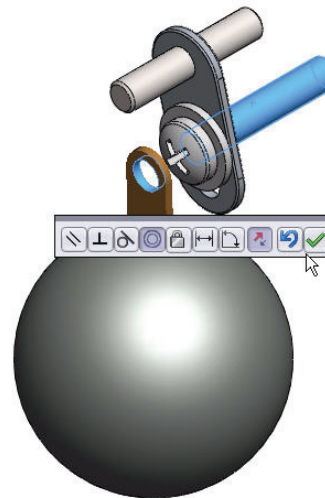



## SolidWorks

- **Rotate** the assembly to view the inside flat face of the Flat component as illustrated.
- Click the inside **front face** of the Flat part as illustrated.



Face<3>@Flat-1 is displayed in the Mate Selection box.

- Rotate the **assembly** to view the front face of the Eye Hook as illustrated
- Click the **front face** of the Eye Hook. Face<4>@Weight-Hook is displayed in the Mate Selection box. The Mate Pop-up toolbar is displayed.

Coincident is selected by default. The results of the mate is displayed in the Graphics window.

- Click the **Add/Finish Mate**  tool from the Mate Pop-up toolbar.
- Click **OK**  from the Mate PropertyManager.

### 3 Save the model.

- Click **Isometric**  view.
- Click **Save** . View the Pan Cross Head part, CR-PHMS in the FeatureManager.

## Assembling the Trebuchet

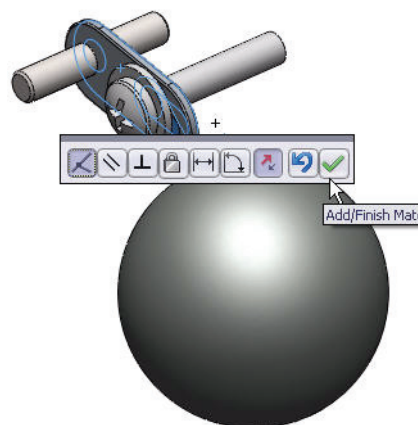
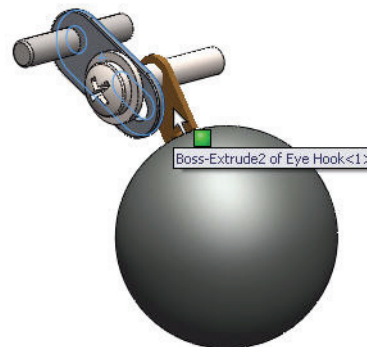
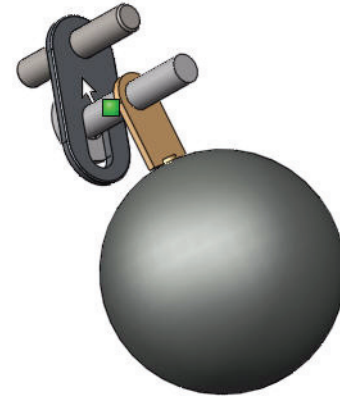

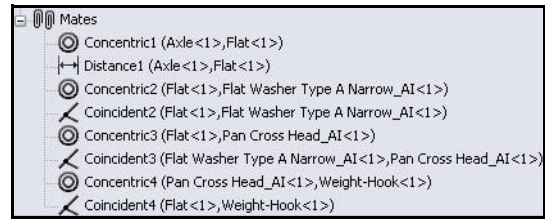

#### 4 View the Mates.

- **Expand** the Mates folder from the FeatureManger. View the inserted mates



#### 5 Insert a Parallel Mate.

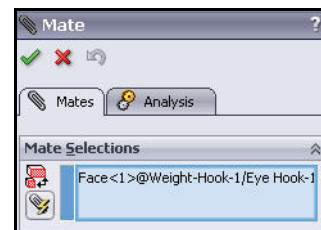
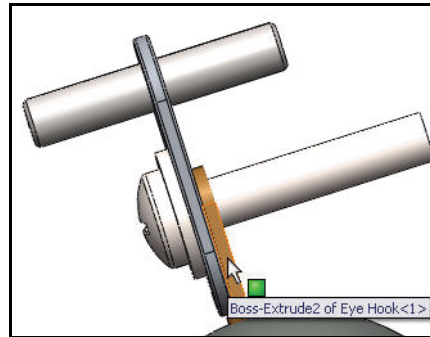

Insert a Parallel mate to control the Weight movement with the Flat component. Insert a Parallel mate between the vertical face of the Flat and the vertical face of the Weight-Hook.

- Click the **Zoom to Area**  tool.
- **Zoom in** on the vertical face of the Counter Weight as illustrated.
- Click the **Zoom to Area**  tool to deactivate.
- Click the **vertical face** of the Weight-Hook as illustrated.
- Click the **Mate**  tool from the Assembly toolbar. Face<1>@Weight-Hook-1 is displayed in the Mate Selection box.



## SolidWorks

## Assembling the Trebuchet

- Click the **vertical face** of the Flat as illustrated. Face<2>@Flat-1 is displayed in the Mate Selection box.
- Click **Parallel** in the Mate Pop-up menu.
- Click the **Add/Finish Mate**  tool from the Mate Pop-up toolbar.
- Click **OK**  from the Mate PropertyManager.

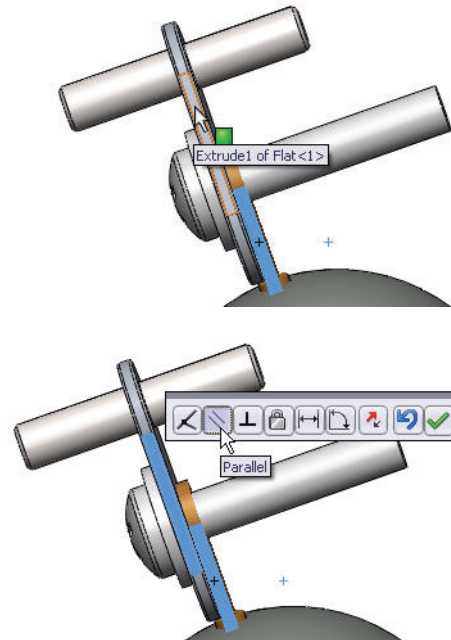

### 6 View the Mates.

- **Expand** the Mates folder from the FeatureManger. View the inserted Parallel mate.

### 7 Save the model.

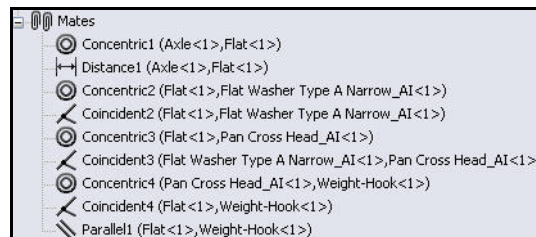

- Click **Isometric**  view.
- Click **Save** .



## Inserting the Second Washer

### 1 Insert the second Washer.

View the mating edge.

- Click the **Zoom to Area**  tool.
- **Zoom in** on the Eye Hook circular edge as illustrated.
- Click the **Zoom to Area**  tool to deactivate.

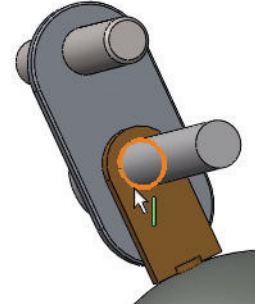

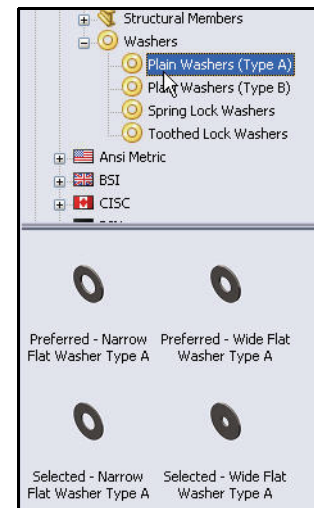
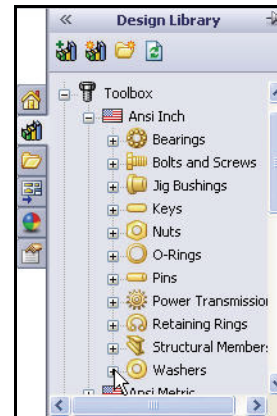

### 2 Display the SolidWorks Design Library.

- Click the **Design Library**  tab.
- **Expand** the Toolbox folder.
- **Expand** the Ansi Inch folder.
- **Expand** the Washers folder.
- Click the **Plain Washers Type A** folder. Various types of Machine Screws are displayed.
- **Drag and drop** the Preferred-Narrow Flat Washer Type A into the Graphics window on the **circular edge** of the Eye Hook part as illustrated. The Preferred - Narrow Flat Washer Type A PropertyManager is displayed.



## SolidWorks

- Select **10** for Size. Accept the default settings.
- Click **OK**  from the Preferred - Narrow Flat Washer Type A PropertyManager.
- Click **Cancel**  from the Insert Components PropertyManager.

### 3 Fit the model to the Graphics window.

- Click the **f** key.

### 4 Save the model.

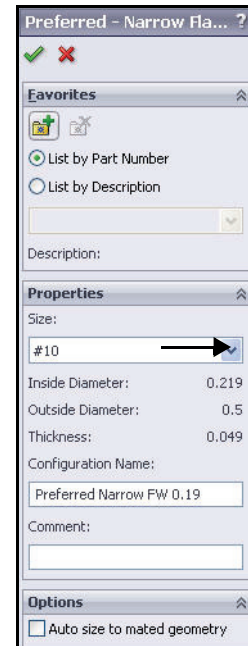
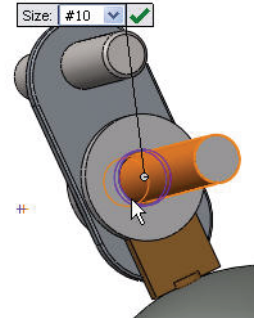

- Click **Save** . View the second Flat Washer Type A component, FW 0.19 in the FeatureManager.

## Assembling the Trebuchet



## Inserting a Hex Nut

### 1 Insert a Hex Nut.

- Click the **Zoom to Area**  tool.
- **Zoom in** on the circular edge of the second washer as illustrated.
- Click the **Zoom to Area**  tool to deactivate.

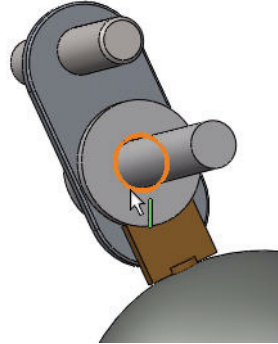

### 2 Display the SolidWorks Design Library.

- Click the **Design Library**  tab.
- **Expand** the Toolbox folder.
- **Expand** the Ansi Inch folder.
- **Expand** the Nuts folder.
- Click the **Machine Screw** folder.
- **Drag and drop** the Machine Screw Nut Hex into the Graphics window on the **circular edge** of the second washer as illustrated.

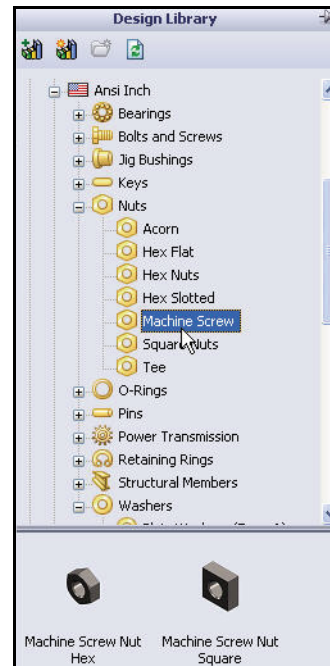

- View the results.

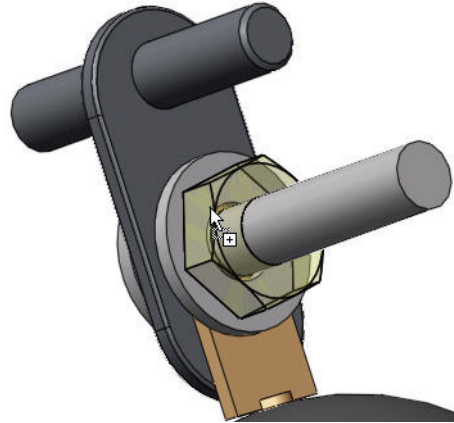

The Machine Screw Nut Hex PropertyManager is displayed.

- Select **10-24** for size. Accept the default settings.
- Click **OK**  from the Machine Screw Nut Hex PropertyManager.
- Click **Cancel**  from the Insert Components PropertyManager.

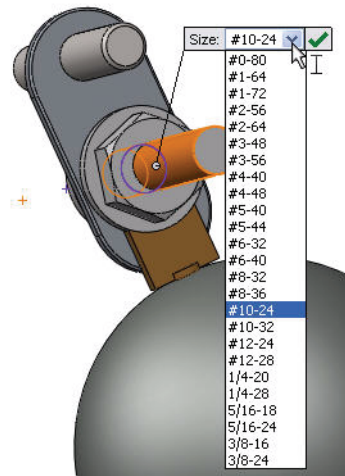

### 3 Save the model.

- Click **Isometric**  view.
- Click **Save** .

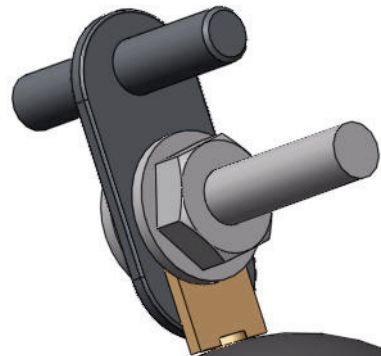

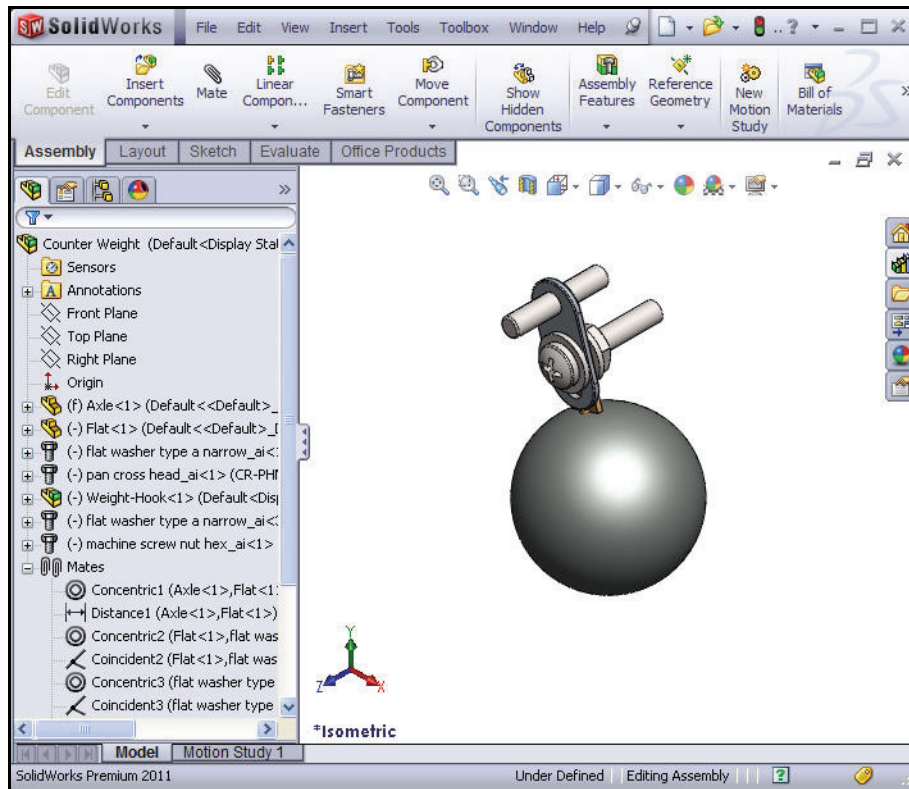

- 4 **Close all models.**
  - Click **Window, Close All** from the Menu bar toolbar.

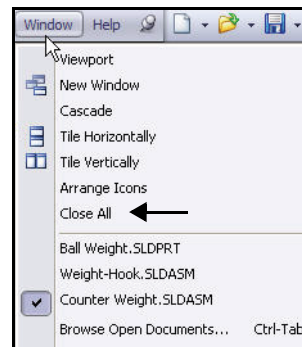

## Creating the Trebuchet Assembly

### 1 Create the Trebuchet assembly.

- Click **New**  from the Menu bar toolbar.
- Double-click **Assembly** from the default Templates tab. The Begin Assembly PropertyManager is displayed.

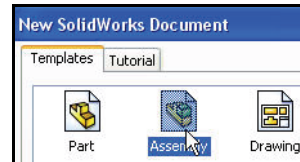

### 2 Insert the Catapult Base assembly.

- Click **Browse**.
- Select the **SolidWorks-Trebuchet** folder.
- Select **Assembly** for Files of type.
- Double-click **Catapult Base Assembly**. The Catapult Base assembly is displayed in the Graphics window. The Assembly FeatureManager is displayed.

### 3 Fix the component to the Origin.

- Click **OK**  from the Begin Assembly PropertyManager. The component is displayed in the FeatureManager as fixed (f).

- Click **Isometric**  view.

### 4 Deactivate the Origins.

- Click **View**, un-check **Origins** from the Menu bar menu. Note: If required, deactivate the default reference planes.

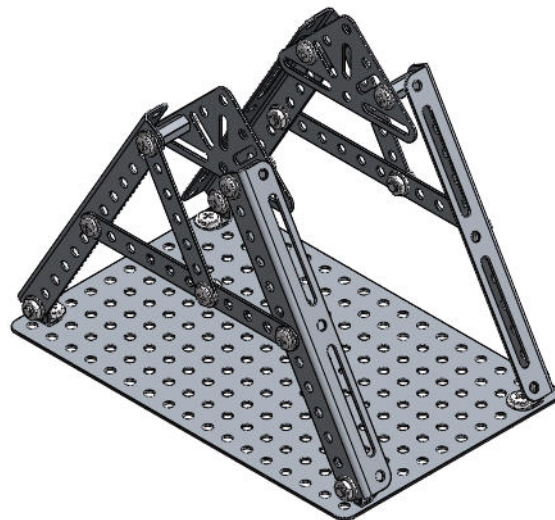

### 5 Save the assembly.

- Click **Save** .
- Click **Save All**.
- Enter **Trebuchet** for File name in the SolidWorks-Trebuchet folder. The Save as type is Assembly (\*.asm,\*.sldasm).
- Click **Save**. The Trebuchet FeatureManager is displayed.

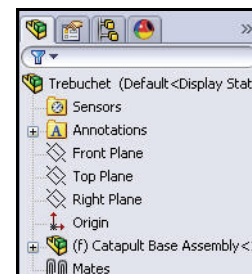

## 6 Set Overall Drafting Standard.

- Click **Options**  **Document Properties** tab from the Menu bar toolbar. The Document Properties - Drafting Standard dialog box is displayed.
- Select **ANSI** from the drop-down menu for Overall drafting standard.

## 7 Set unit system and length.

- Click **Units**.
- Click **IPS** (inch, pound, second) for Unit system.
- Select **.123** for Length unit decimal place.
- Select **None** for Angle decimal place.
- Select **millimeters** for Dual Dimension Length.

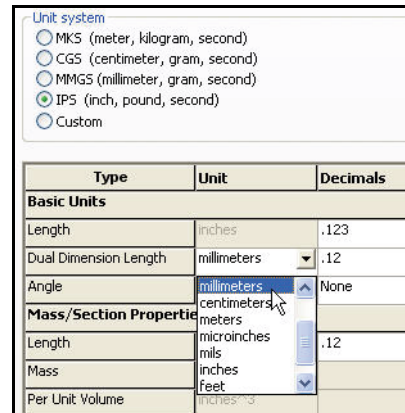

## 8 Set dual unit display.

- Click **Dimensions** from the Document Properties dialog box.
- Check the **Dual dimensions display** box.

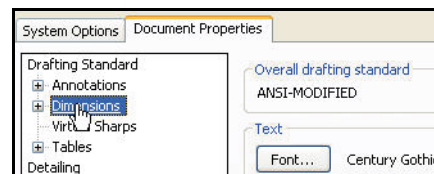

## 9 Set System options.

- Click **OK** from the Document Properties-Dimensions dialog box.

## 10 Insert the Catapult Arm assembly.

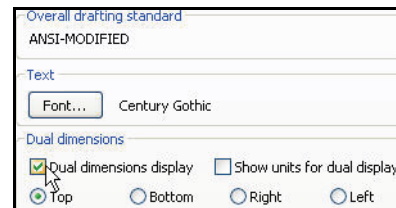

- Click the **Insert Components**  tool from the Assembly toolbar. The Insert Component PropertyManager is displayed.
- Click **Browse**.
- Select the **SolidWorks-Trebuchet** folder.
- Select **Assembly** for Files of type.
- Double-click **Catapult Arm Assembly**.

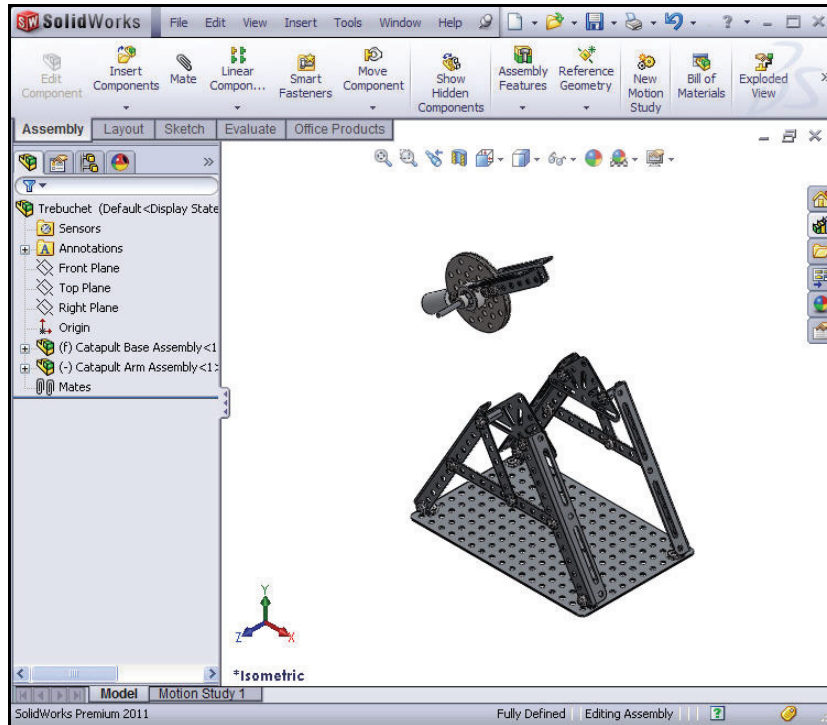

- Click a **position** above the Catapult Base in the Graphics window. The Catapult Arm assembly is displayed in the FeatureManager.







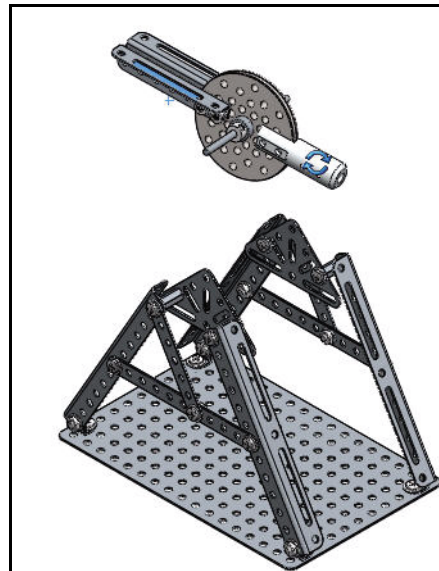

#### 11 Rotate the Catapult Arm.

- Click the **Rotate Component**  tool from the Consolidated Assembly toolbar.
- **Click** and **rotate** the Catapult Arm as illustrated.
- Click **OK**  from the Rotate Component PropertyManager to deactivate the tool.

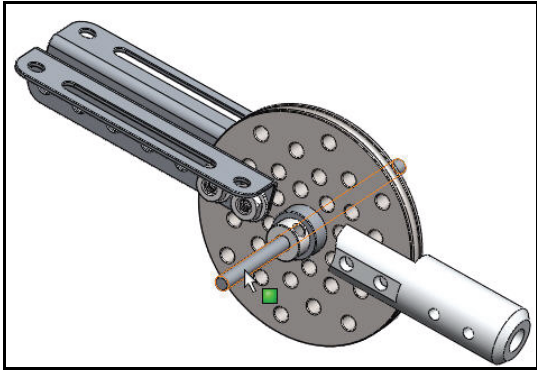

**12 Create a Concentric Mate.**

Create a Concentric mate between the cylindrical face of the 4in[101.6mm] Axle shaft and the top inside circular face of the Triangle.

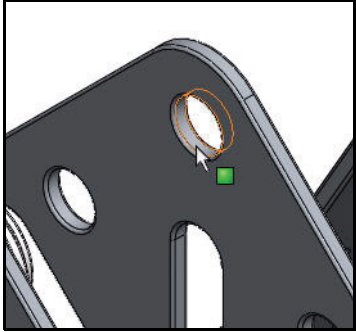
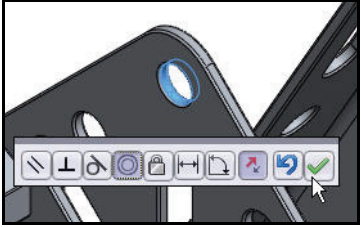
- Click the **Zoom to Area**  tool.
  - **Zoom in** on the cylindrical face of the Axle as illustrated.
  - Click the **Zoom to Area**  tool to deactivate.
  - Click the **cylindrical face** of the 4in[101.6mm] Axle shaft as illustrated.
  - Click the **Mate**  tool from the Assembly toolbar. Face<1>@Catapult Arm is displayed in the Mate Selection box.
  - Click the **Zoom to Area**  tool.
  - **Zoom in** on the top circular face of the front side of the Triangle.
  - Click the **Zoom to Area**  tool to deactivate.
- 
- Click the **top inside cylindrical face** of the Triangle. Face<2>@Catapult Base is displayed in the Mate Selection box. The Mate Pop-up toolbar is displayed. Concentric mate is selected by default.
  - Click the **Add/Finish Mate**  tool from the Mate Pop-up toolbar.
  - Click **OK**  from the Mate PropertyManager.
- 
- 

**13 Fit the model to the Graphics window.**

- Press the **f** key.

**14 Align the Catapult Base and the Catapult Arm.**

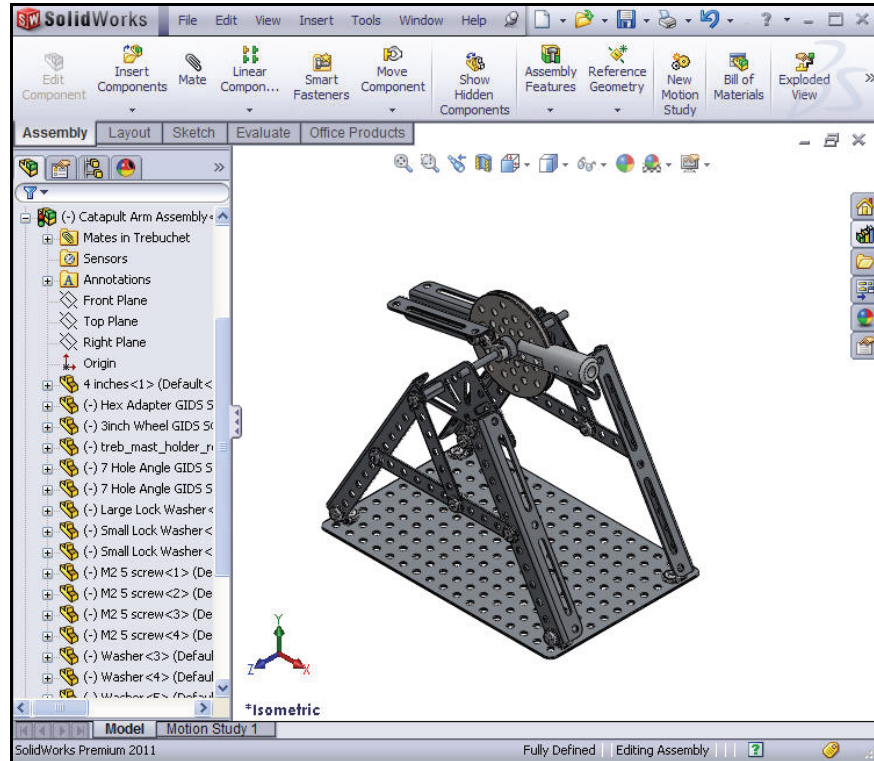

- **Click and drag** the Catapult Arm into the Catapult Base as illustrated.

**15 Create a Distance Mate.**

Create a Distance mate between the flat face of the 4in[101.6mm] Axle shaft and the flat face of the Triangle.

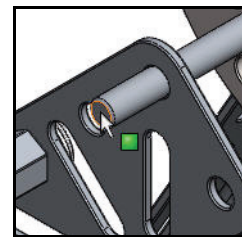
- Click the **flat front circular face** of the 4in[101.6mm] Axle shaft.
- Click the **Mate**  tool from the Assembly toolbar. Face<1>@Catapult Arm is displayed in the Mate Selection box.



- Click the **flat face** of the Triangle as illustrated.  
Face<2>@Catapult Base is displayed in the Mate Selection box.
- Click **Distance** mate in the Mate Pop-up toolbar.
- Enter **.400**[10.2].
- Click the **Add/Finish Mate**  tool from the Mate Pop-up toolbar.
- Click **OK**  from the Mate PropertyManager.

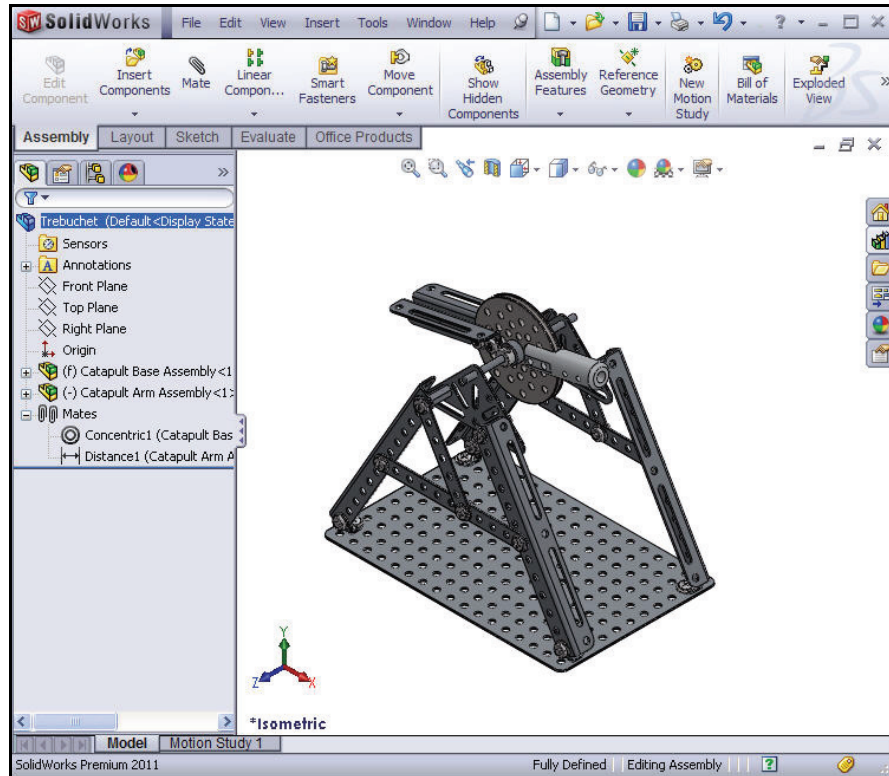
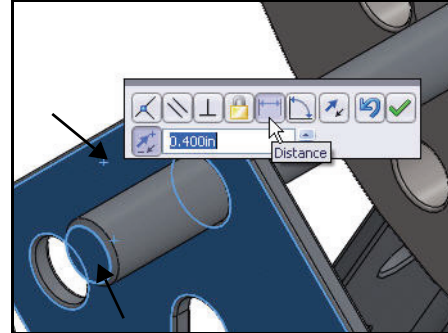

**16 Fit the model to the Graphics window.**



- Press the **f** key.

**17 Save the model.**

- Click **Isometric**  view.

- Click **Save** .

**18 Show the Hidden parts in the Catapult Arm assembly.**

- **Expand** the Catapult Arm sub-assembly from the FeatureManager.
- Right-click **Launcher<2>** from the Trebuchet FeatureManager.
- Click the **Show components**  tool from the Context toolbar. The Launcher assembly is displayed in the Graphics window.
- Click **Isometric**  view.

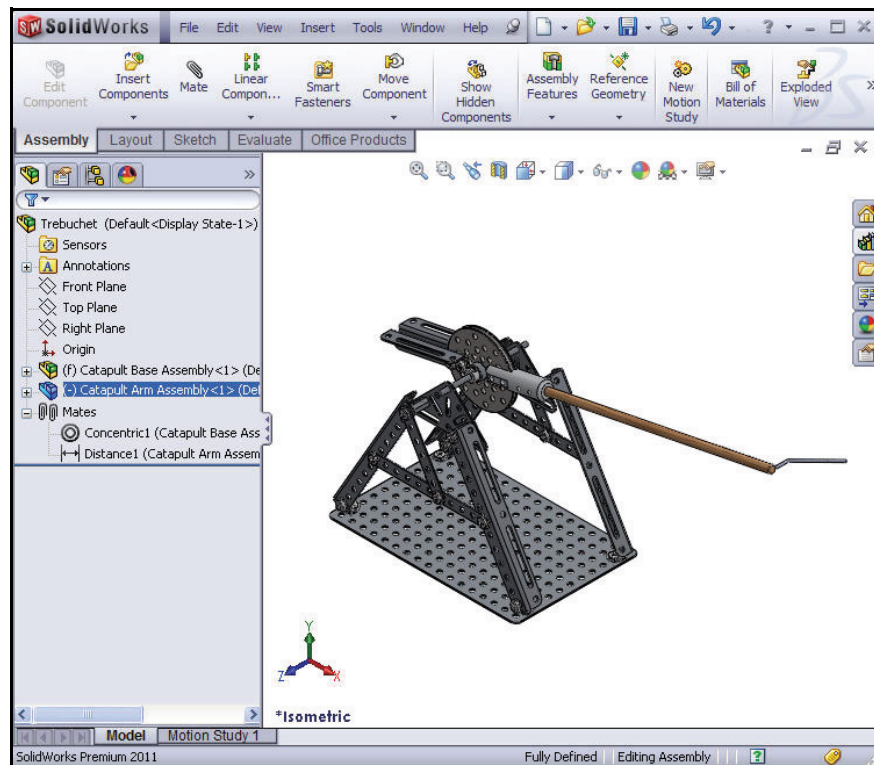
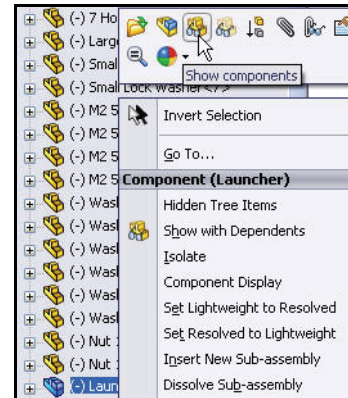





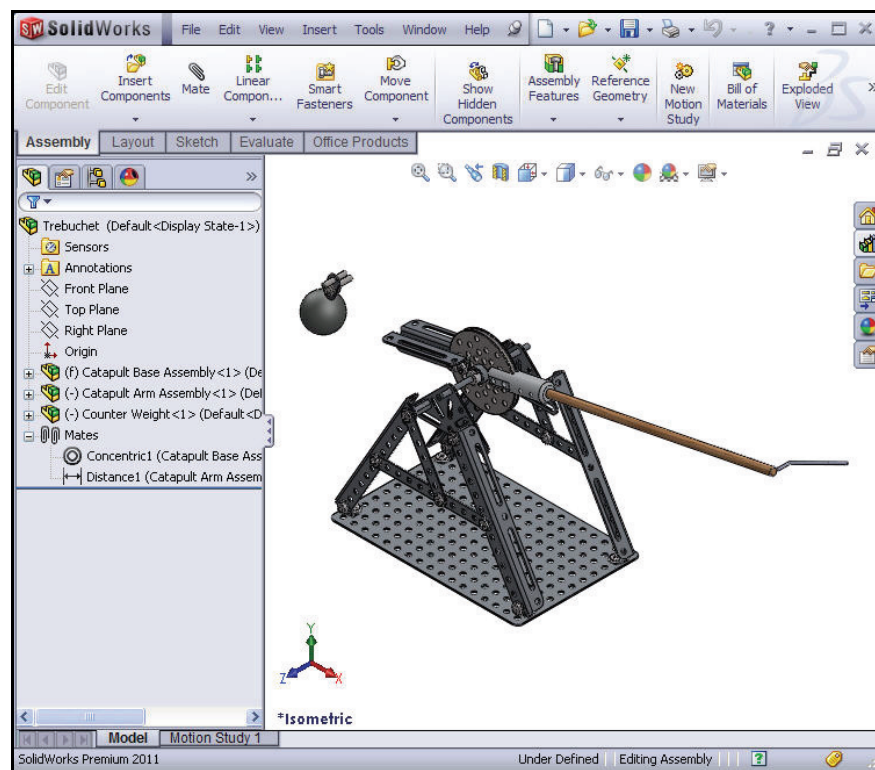

**19 Insert the Counter Weight assembly.**

- Click the **Insert Components**  tool from the Assembly toolbar. The Insert Component PropertyManager is displayed.
- Click **Browse**.
- Select the **SolidWorks-Trebuchet** folder.
- Select **Assembly** for Files of type.
- Double-click **Counter Weight**.
- Click a **position** to the left of the Trebuchet. The Counter Weight assembly is displayed in the Trebuchet FeatureManager.

**20 Create a Concentric Mate.**

Create a Concentric mate between the Axle and the 7 Hole Angle bar of the Catapult Arm.

- Click the **Zoom to Area**  tool from the Heads-up View toolbar.
  - **Zoom in** on the Axle in the Counter Weight assembly, as illustrated.
  - Click the **Zoom to Area**  tool to deactivate.
  - Click the **cylindrical face** of the Axle as illustrated.
  - Click the **Mate**  tool from the Assembly toolbar. Face<1>@Counter Weight is displayed in the Mate Selection box.
  - Click the **Zoom to Area**  tool.
  - **Zoom in** on the inside circle face of the 7 Hole Angle bar of the Catapult Arm.
  - Click the **Zoom to Area**  tool to deactivate.
  - Click the **inside cylindrical face** as illustrated.
- Face<2>@Catapult Arm is displayed in the Mate Selection box. Concentric is selected by default.
- Click the **Add/Finish Mate**  tool from the Mate Pop-up toolbar.

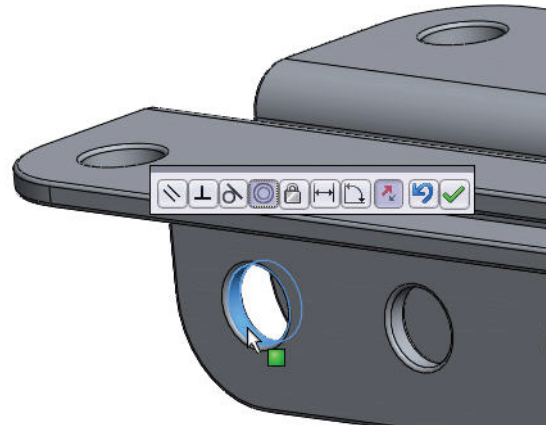
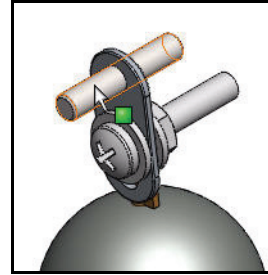

**21 Align the Counter Weight assembly.**

- Click and Drag the **Counter Weight** assembly into the 7 Hole Angle of the Catapult Arm as illustrated.

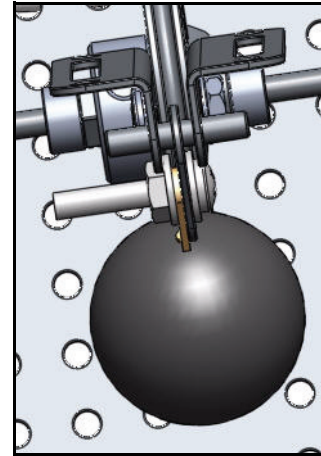
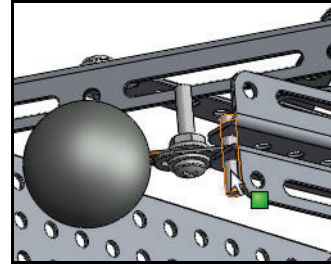
**22 Create a Distance Mate.**

Create a Distance mate between the flat face of the Axle in the Counter Weight assembly and the flat face of the 7 Hole Angle of the Catapult Arm.

- Click the **flat front circular face** of the Axle as illustrated. Face<3>@Counter Weight is displayed in the Mate Selection box.

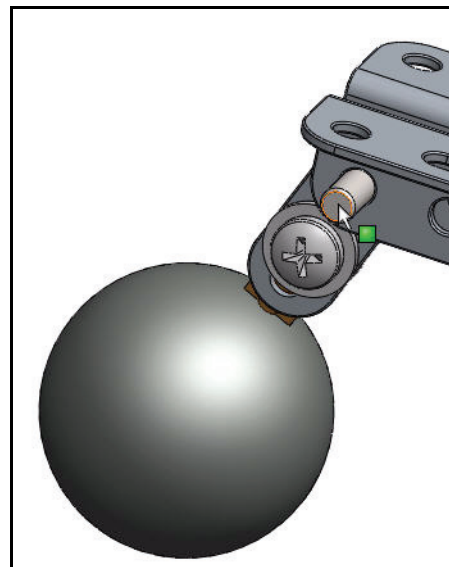

- Click the **flat front face** of the 7 Hole Angle as illustrated.  
Face<4>@Catapult Arm is displayed in the Mate Selection box.
- Click **Distance** mate from the Mate Pop-up toolbar.
- Enter **.200**[5.08].
- Click the **Add/Finish** **Mate**  tool from the Mate Pop-up toolbar.
- Click **OK**  from the Mate PropertyManager.

**23 Fit the model to the Graphics window.**

- Press the **f** key.

**24 Save the model.**

- **Rebuild** the model.
- Click **Isometric**  view.
- Click **Save** .
- Click **Save All**.

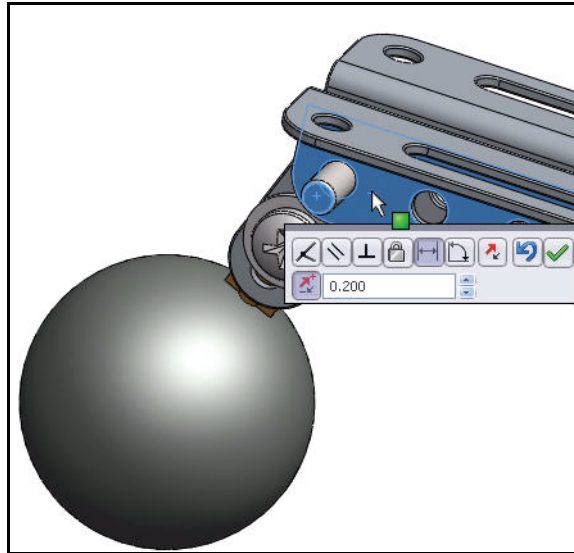

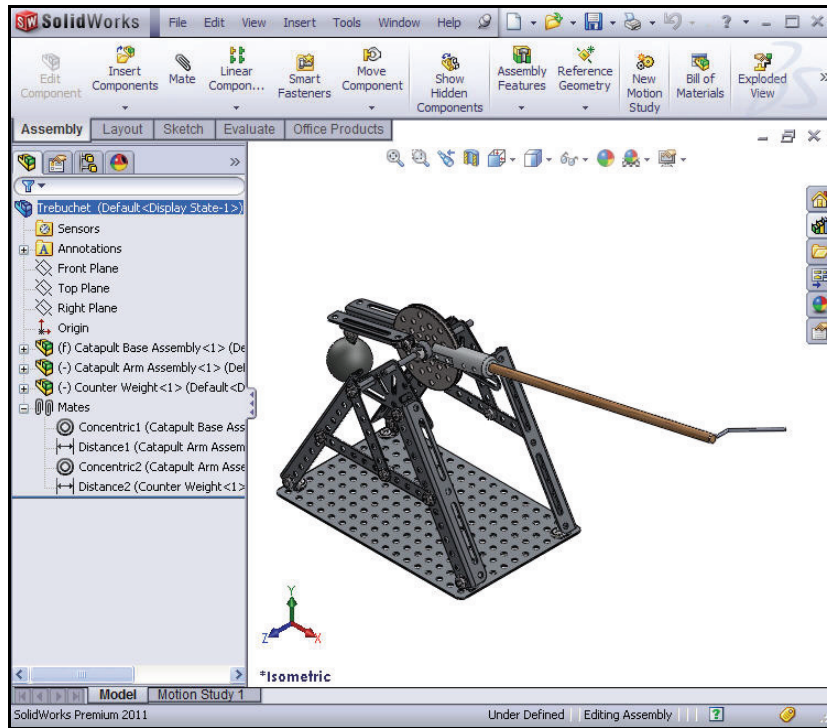

In this lesson you renamed a component, and created the following assemblies:

- Weight-Hook.
- Trebuchet.

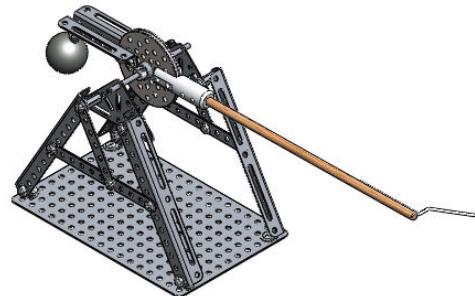

## SolidWorks

You inserted the following SolidWorks Toolbox components:

- Preferred-Narrow Flat Washer Type A.
- Pan Cross Head Screw.
- Machine Screw Nut Hex.

## Assembling the Trebuchet

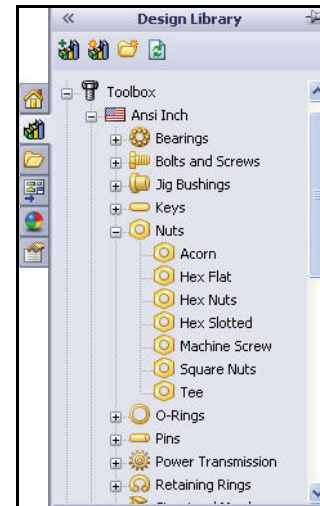

You created and applied the following Standard mates:

- Parallel.
- Tangent.
- Concentric.
- Coincident.
- Distance.

In Lesson 4 you will experience the power and capabilities of SolidWorks SimulationXpress.

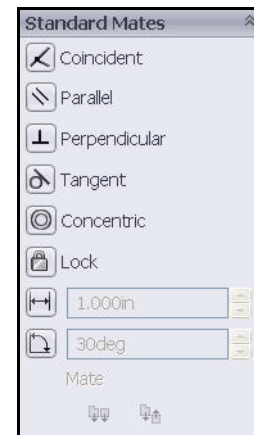



## Lesson 4 Analyzing the Trebuchet

When you complete this lesson, you will have experienced the power and capabilities of SolidWorks SimulationXpress & SolidWorks Motion, you will be able to:

- Understand the benefits of analysis.
- Appreciate the ease-of-use of SimulationXpress™ to perform analysis.
- How SimulationXpress is integrated with SolidWorks.
- The steps for performing up front analysis on your designs.
- The ability to document your analysis findings automatically.
- Recognize the performance aspects and time savings before physical prototyping.
- Optimize cost savings by reducing unnecessary material.
- The method to update your assembly based on the analysis results.
- The benefits of using SolidWorks Motion™ to perform motion simulations on your assembly.

## Stress Analysis of the 7 Hole Flatbar Part

In this section, you will use SimulationXpress to quickly analyze the 7 Hole Flatbar part which is used in the Trebuchet assembly. Performing analysis is quick and easy to do. There are only six steps required:

1. Set the default units and specify a folder to save the analysis results.
2. Apply Fixtures.
3. Apply Loads.
4. Apply Material.
5. Run the analysis.
6. Optimize the part, (Optional).
7. View the results.

You will perform a first-pass analysis on the 7 Hole Flatbar part and assess its Factor of Safety and view the applied stresses. You will then modify the 7 Hole Flatbar and re-run the analysis.

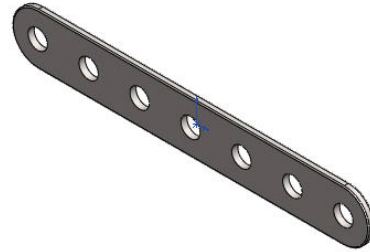

## Design Analysis

After building your design in SolidWorks; 7 Hole Flatbar you may need to answer questions like:

- Will the part break under a specified load?
- How will the part deform under a specified load?
- Can I use less material without affecting performance?

In the absence of analysis tools, expensive prototype-test design cycles take place to ensure that the product's performance meets customer expectations. Design analysis makes it possible to perform design cycles quickly and inexpensively on computer models instead of testing costly physical prototypes. Even when manufacturing costs are not important considerations, design analysis provides significant product quality benefits, enabling engineers to detect design problems far sooner than the time it takes to build a prototype. Design analysis also facilitates studies of many design options and aids in developing optimized designs.

## Stress Analysis

Stress analysis or static analysis is the most common design analysis test. It predicts how the model deforms under loading. It calculates displacements, strains, and stresses throughout the part based on material, restraints, and loads. A material fails when the stress reaches a certain level. Different materials fail at

different stress levels. SimulationXpress uses linear static analysis, based on the Finite Element Method (FEM), to calculate stresses. Linear static analysis makes the following assumptions to calculate stresses in the part:

- **Linearity Assumption:** Means that the induced response is directly proportional to the applied loads.
- **Elasticity Assumption:** Indicates that the part returns to its original shape if the loads are removed.
- **Static Assumption:** Implies that loads are applied slowly and gradually until they reach their full magnitudes.

### SolidWorks SimulationXpress Wizard User Interface

SolidWorks SimulationXpress guides you through six steps to define material properties, restraints, loads; to analyze the part; optimize the part; and to view your results. The SolidWorks SimulationXpress interface consists of the following components:

**Welcome** tab: Allows you to set the default units and to specify a folder for saving the analysis results.

**Fixtures** tab: Apply fixtures to faces of the part.

**Loads** tab: Apply forces and pressures to faces of the part.

**Material** tab: Applies material properties to the part. The material can be assigned from the material library or you can input the material properties.

**Run** tab: You can select to analyze with the default settings or change the settings.

**Optimize** tab: Optimize a model dimension based on a specified criterion.

**Results** tab: View analysis results in the following ways:

- Show critical areas where the factor of safety is less than a specified value.
- Display the stress distribution in the model with or without annotation for the maximum and minimum stress values.

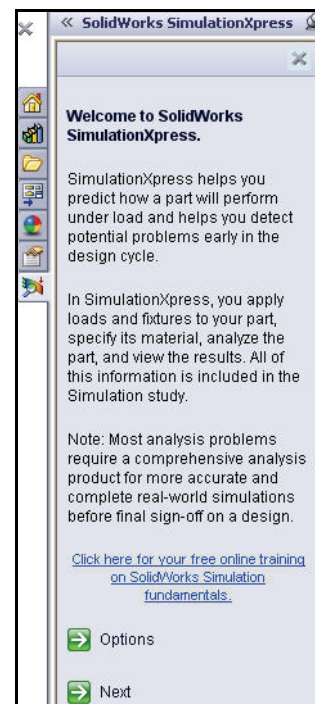

- Display resultant displacement distribution in the model with or without annotation for the maximum and minimum displacement values.
- Show deformed shape of the model.
- Generate a report.
- Generate eDrawings files for the analysis results.

**Start Over** button: Click this button to delete existing analysis data and results and start a new analysis session.

**Update** button: Runs SolidWorks SimulationXpress analysis if the fixtures and loads are resolved. Otherwise, it gives a message and you need to resolve the invalid fixtures or loads. The Update button appears if you change geometry after applying loads or fixtures. It also appears if you change material properties, fixtures, loads, or geometry after completing the analysis.

### Analyze the 7 Hole Flatbar Part

You will perform stress analysis on the 7 Hole Flatbar part in this section. The 7 Hole Flatbar is used to support the Trebuchet assembly.

### Opening the 7 Hole Flatbar Part

- 1 **Open the 7 Hole Flatbar part.**
  - Click **Window, Close All** from the Menu bar menu.
  - Click **Open**  from the Menu bar toolbar.
  - Select the **SolidWorks-Trebuchet\SimulationXpress** folder.
  - Select **Part** for Files of type.
  - Double-click **7 Hole Flatbar**. The 7 Hole Flatbar part is displayed in the Graphics window.

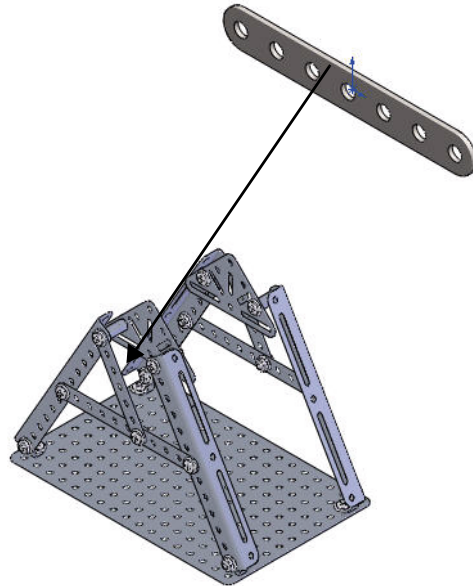

- 2 **Change the view orientation.**
  - If the part is not displayed in an Isometric view, click the **Isometric**  view.

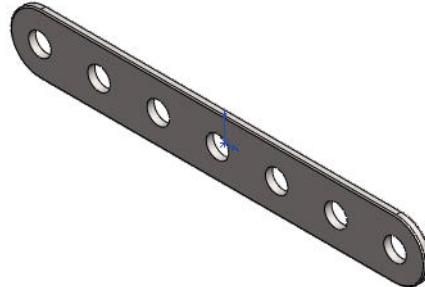

- 3 **Review the Axle material.**
  - Right-click **AISI 304** from the 7 Hole Flatbar FeatureManager.
  - Click **Edit Material**. The physical material properties are displayed in the Materials dialog box. The AISI 304 material properties are used in SolidWorks SimulationXpress.

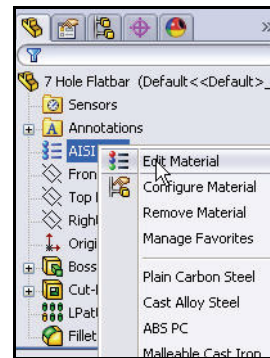

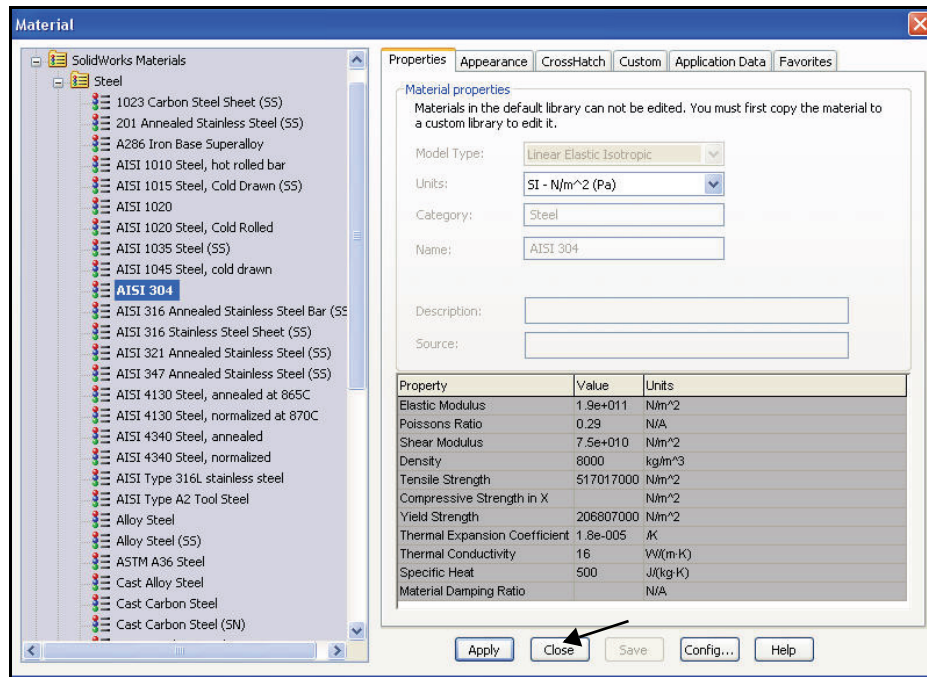

- **View** your options.
- Click **Close** from the Material dialog box to return to the Part FeatureManager.

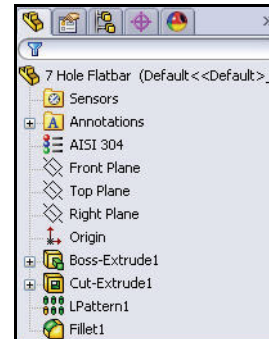

## Running SolidWorks SimulationXpress and Setting Analysis Options

Once the part is open in SolidWorks, you can launch the SimulationXpress application and start your analysis right away. In the Options dialog box, you can set the default system of units and the destination folder for the analysis results.

### Systems of Units

The following table lists the quantities used by SimulationXpress and their units in different systems of units:

		SI	English (IPS)	Metric
Loads	Force	N (Newton)	lb (pound)	Kgf
	Pressure	N/m <sup>2</sup>	psi (lb/in <sup>2</sup> )	Kgf/cm <sup>2</sup>
Material Properties	Ex: Elastic modulus	N/m <sup>2</sup>	psi (lb/in <sup>2</sup> )	Kgf/cm <sup>2</sup>
	NUXY: Poisson's ratio	No units	No units	No units
	SIGYLD: Yield Strength	N/m <sup>2</sup>	psi (lb/in <sup>2</sup> )	Kgf/cm <sup>2</sup>
	DENS: Mass density	Kg/m <sup>3</sup>	lb/in <sup>3</sup>	Kg/cm <sup>3</sup>
Results	Equivalent Stress	N/m <sup>2</sup>	psi (lb/in <sup>2</sup> )	Kgf/cm <sup>2</sup>

**Table 1: Systems of units used in SimulationXpress**

## Running SimulationXpress and Setting Analysis Options

- 1 **Run SolidWorks SimulationXpress.**  
Click **Tools, SimulationXpress** from the Menu Bar menu.

The SolidWorks SimulationXpress application starts with the Welcome tab selected.

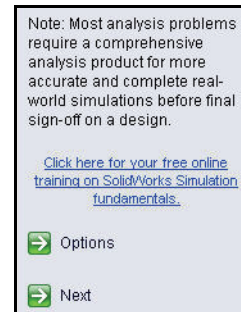

**Tip:** You can quickly run SimulationXpress by clicking **SimulationXpress Analysis Wizard** from the Evaluate tab in the CommandManager.



- 2 **Set System units.**  
Click the **Options** button from the Welcome screen.

Set System of units to **English (IPS)** [SI, (MMGS)].

Set the Results location to the **SolidWorks-Trebuchet\SimulationXpress** folder.

Click **OK**.

Click **Next**. View the Study FeatureManager.

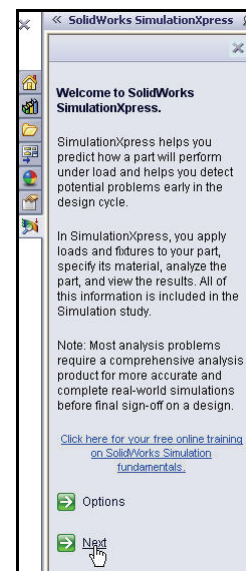
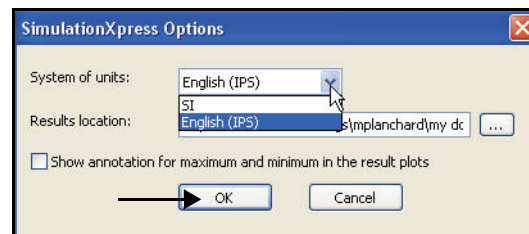

## Applying a Fixture

### 1 Apply a fixture.

The Fixtures tab is activated. The Fixture section collects information on where the 7 Hole Flatbar is fixed to the frame. You can specify multiple sets of fixtures. Each set can have multiple faces.

Click the **Add a fixture** button. The Fixture PropertyManager is displayed.

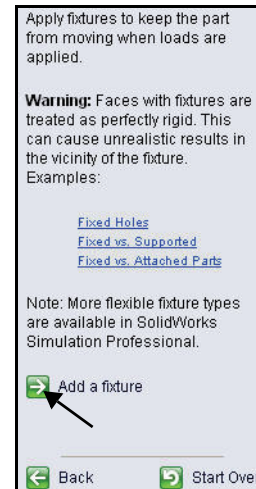

### 2 Select the fixed faces.

Click the **inside left face** of the first hole as illustrated. The fixture simulates a bolt through the hole to fix the Trebuchet base assembly. Face<1> is displayed in the Fixed Geometry box. Cut-Extrude1 is highlighted in the fly-out FeatureManager.

**Zoom in** on the inside right face of the last hole as illustrated.

Click the **inside right face** of the last hole. Face <1> and Face<2> are displayed in the Fixed Geometry box.

Click **OK**  from the Fixture PropertyManager. View the updated Study tree.

**Note:** To add a new fixture set, click the **Add a fixture** button.

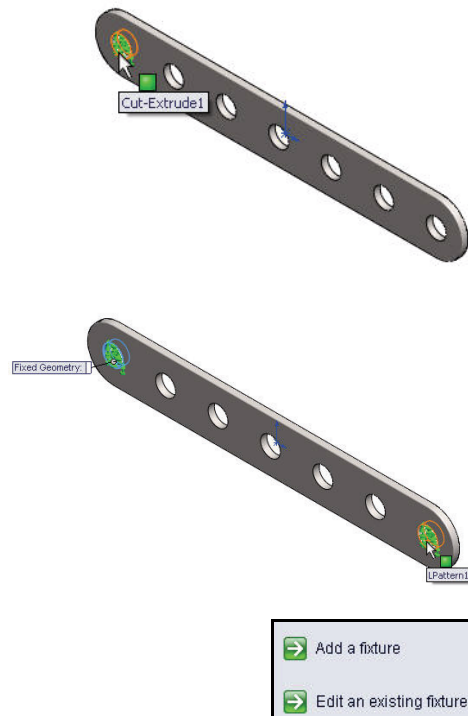

## Applying a Load

Using the Loads tab, you can specify the loads acting on the part. A load can either be a force or a pressure.

You can apply multiple loads to a single face or to multiple faces. The direction of a force can be specified with respect to planes or normal to selected faces. The pressure is always applied normal to selected faces.

In this lesson, you will supply a single force to the top face of the part.

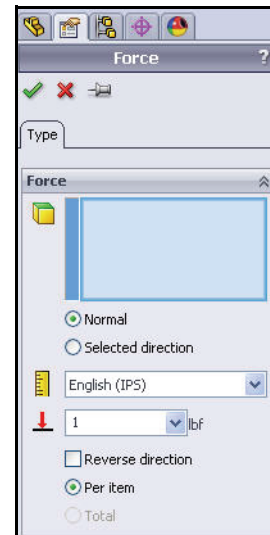
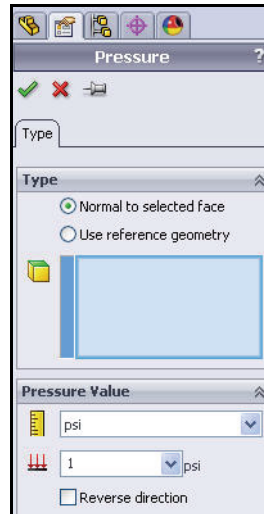
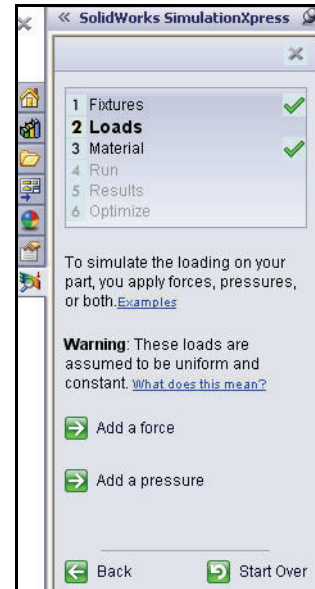

### Applying a Load

**1 Apply a load.**

Click **Next**. Collect information on loads acting on the 7 Hole Flatbar part.

**2 Select a load type.**

Click **Add a force**. The Force PropertyManager is displayed.

**3 Select the face to which the force is applied.**

Click the **front face** of the 7 Hole Flatbar part. Face <1> is displayed in the selection box.

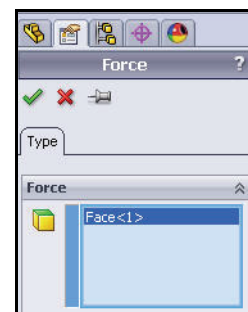
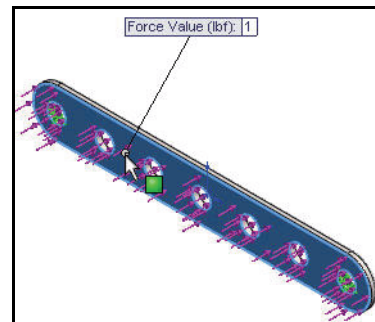
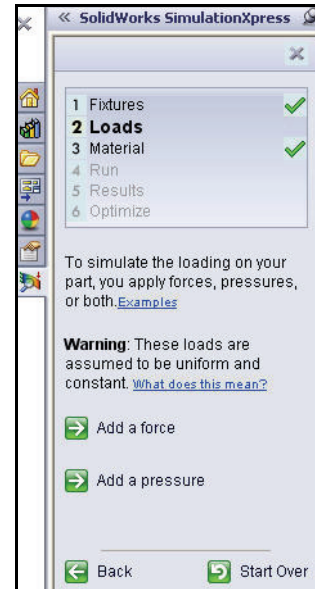

**4 Specify the direction and magnitude of the force.**

Check the **Normal** box.

Select **English (IPS)** [SI] from the pull-down menu as illustrated.

**5 Apply a Force.**

Select **lbf** [SI] from the pull-down menu as illustrated.

Enter **1lbf** for the value of the force. The force points towards the surface of the Flatbar.

Click **OK**  from the Force PropertyManager. View the updated Study tree.

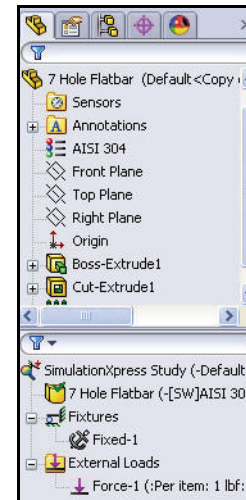
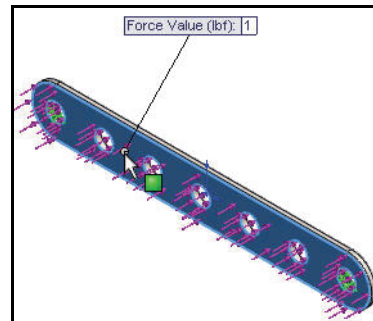
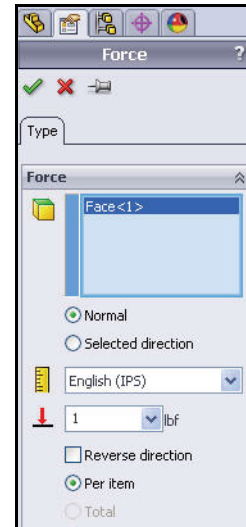

## SolidWorks

- 6 **Assign material to the part.**  
Click **Next**.

The Material tab opens.

## Analyzing the Trebuchet

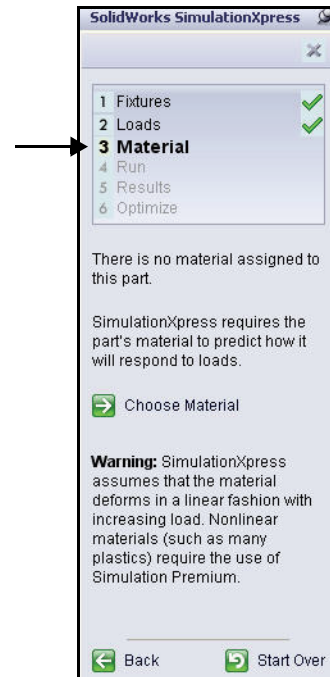
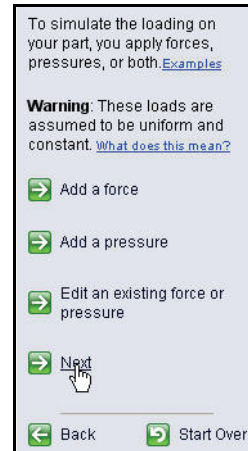

## Assigning Material

The response of the part depends on the material it is made of. SimulationXpress must know the elastic properties of the material of your part. You can pick a material from the SolidWorks material library or define your own material properties. SimulationXpress uses the following material properties to perform stress analysis.

**Elastic Modulus (EX).** For a linear elastic material, the elastic modulus is the stress required to cause a unit strain in the material. In other words, stress divided by the associated strain. The modulus of elasticity was first introduced by Young and is often called the Young's Modulus.

**Poisson's Ratio (NUXY).** Extension of the material in the longitudinal direction is accompanied by shrinking in the lateral directions. For example, if a body is subjected to a tensile stress in the X-direction, then Poisson's Ratio NUXY is defined as the ratio of lateral strain in the Y-direction divided by the longitudinal strain in the X-direction. Poisson's ratios are dimensionless quantities. If not defined, the program assumes a default value of 0.

**Yield Strength (SIGYLD).** SimulationXpress uses this material property to calculate the factor of safety distribution. SimulationXpress assumes that the material starts yielding when the equivalent (von Mises) stress reaches this value.

**Mass Density (DENS).** The density is mass per unit volume. Density units are lb/in<sup>3</sup> in the English system, and kg/m<sup>3</sup> in the SI system. SimulationXpress uses the mass density to include mass properties of the part in the report file.

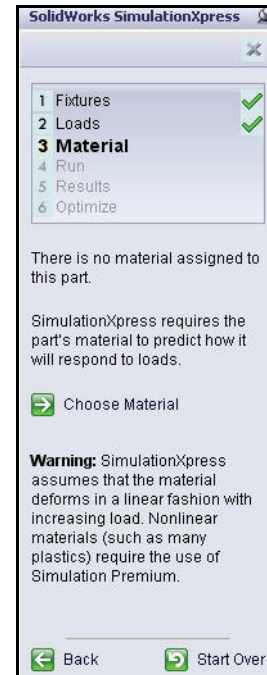

## Assigning Material

### 1 Assign Material to the part.

Click **Choose Material**. The Material dialog box is displayed.

Select **AISI 304**.

Click **Apply**.

Click **Close**. View the updated Study tree. A green check mark indicates that material is applied to the part.

### 2 Run the analysis.

Click **Next**. The Run tab is displayed.

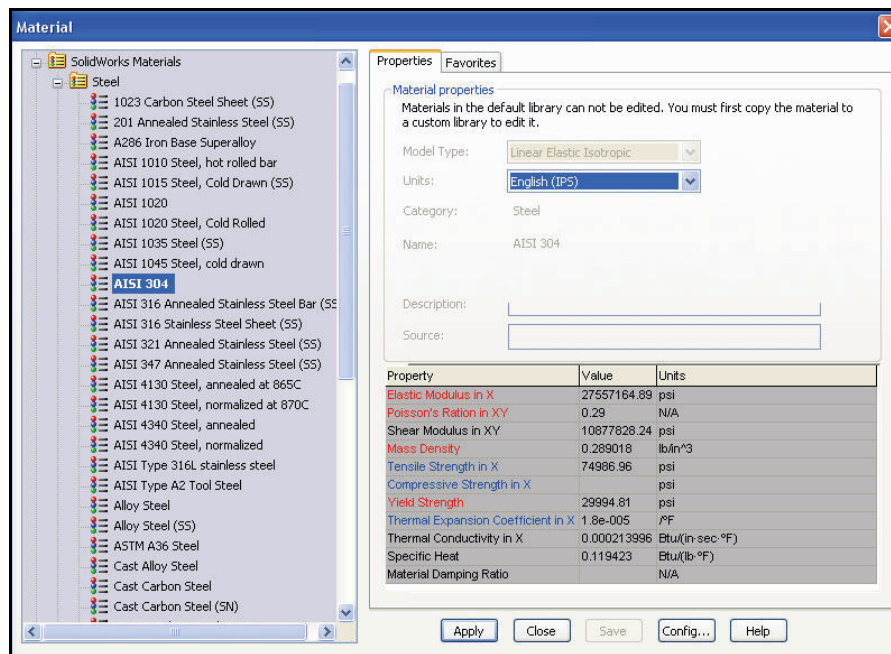
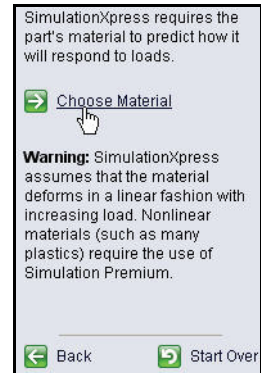

## Running the Analysis

The Analyze tab allows you to run the analysis. SimulationXpress prepares the model for analysis and then calculates displacements, strains, and stresses.

The first phase in the analysis is meshing. Meshing is basically splitting the geometry into small, simple-shaped pieces called finite elements.

Design analysis uses finite elements to calculate the model's response to the applied loads and restraints. SimulationXpress estimates a default element size for the model based on its volume, surface area, and other geometric details. You can instruct SimulationXpress to use the default element size or you can use a different element size.

After meshing the model successfully, the second phase starts automatically. SimulationXpress formulates the equations governing the behavior of each element taking into consideration its connectivity to other elements. These equations relate the displacements to known material properties, restraints, and loads. The program then organizes the equations into a large set of simultaneous algebraic equations. The solver finds the displacements in the X, Y, and Z directions at each node.

Using the displacements, the program calculates the strains in various directions. Finally, the program uses mathematical expressions to calculate stresses.

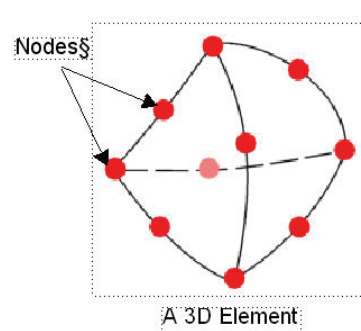
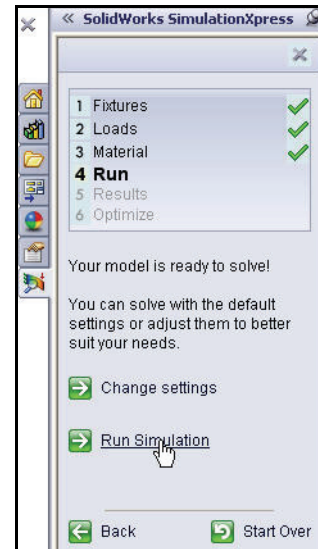

## Running the Analysis

- 1 **Apply the default settings.**  
Click **Run Simulation**. View the results and the updated Study tree.

The analysis starts. When the analysis is complete, a check mark is displayed on the Run and Results tab. View the animation of the part in the graphics area.

- 2 **Stop the animation.**  
Click **Stop animation**.

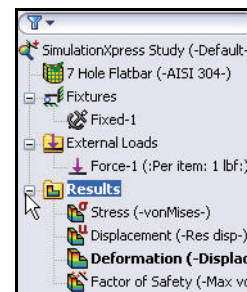
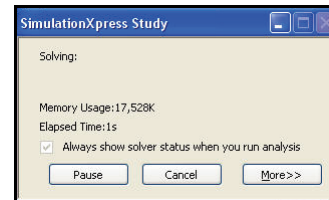
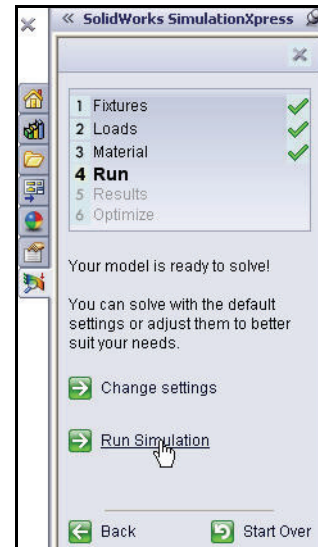

### Viewing Results

Viewing results is an essential step in the analysis process. This is the step in which you evaluate how good your design is at withstanding the specified working conditions.

This step should lead you to make important decisions about whether to accept the design and move to prototyping, make further improvements on the design, or try additional sets of loads and fixtures.

SimulationXpress uses the maximum von Mises stress criterion to calculate the factors of safety. This criterion states that a ductile material starts to yield when the equivalent stress (von Mises stress) reaches the yield strength of the material. The yield strength (SIGYLD) is defined as a material property. SimulationXpress calculates the factor of safety (FOS) at a point by dividing the yield strength by the equivalent stress at that point.

#### Interpretation of factor of safety values:

- A factor of safety less than 1.0 at a location indicates that the material at that location has yielded and that the design is not safe.
- A factor of safety of 1.0 at a location indicates that the material at that location has just started to yield.
- A factor of safety greater than 1.0 at a location indicates that the material at that location has not yielded.
- The material at a location will start to yield if you apply new loads equal to the current loads multiplied by the resulting factor of safety.

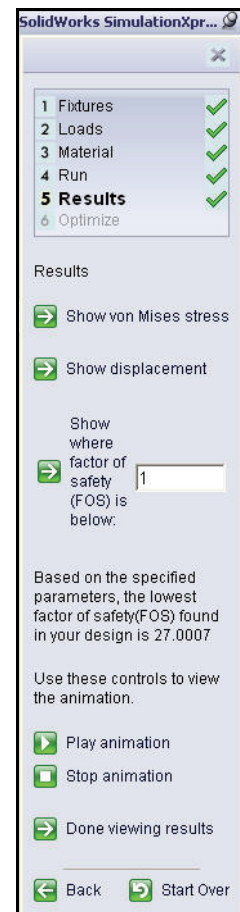
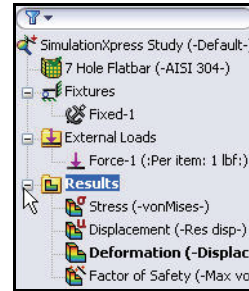

## Stresses

When loads are applied to a body, the body tries to absorb its effects by developing internal forces that, in general, vary from one point to another.

The intensity of these internal forces is called stress. The unit of stress is force per unit area.

In SimulationXpress you can view a stress quantity called the equivalent (or von Mises) stress. While the equivalent stress at a point does not uniquely define the state of stress at that point, it provides adequate information to assess the safety of the design for many ductile materials.

The equivalent stress has no direction. It is fully defined by magnitude with stress units (i.e., force/area). SimulationXpress uses the von Mises Yield Criterion to calculate the factors of safety at different points of the model.

## Viewing the Results

- 1 **View the results.**  
Double-click on the **Stress (-vonMises-)** Results folder. View the results.

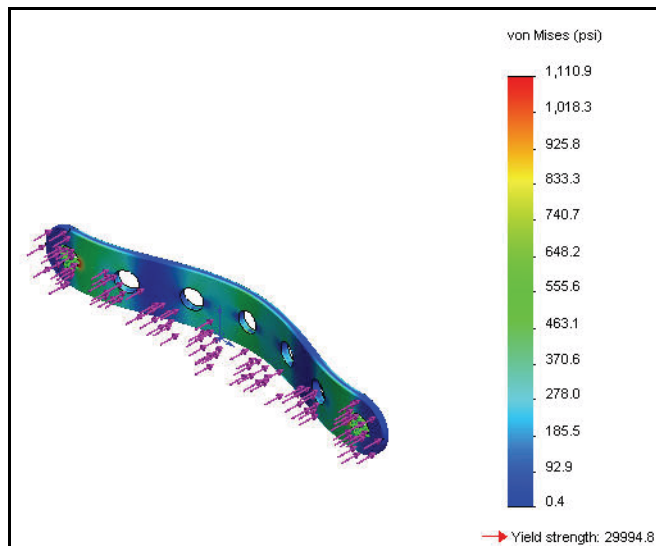
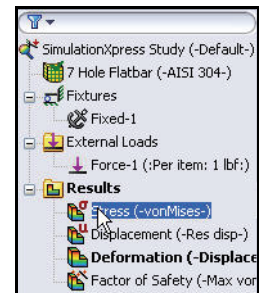

## Analyzing the Trebuchet

## SolidWorks

Double-click on the **Displacement(-Res disp-)** Results folder. View the results.

Double-click on the **Deformation (- Displacement-)** Results folder. View the results.

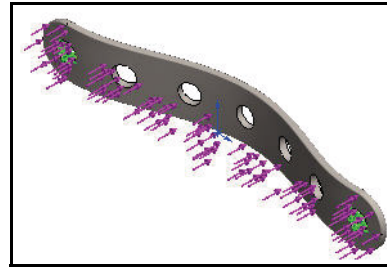
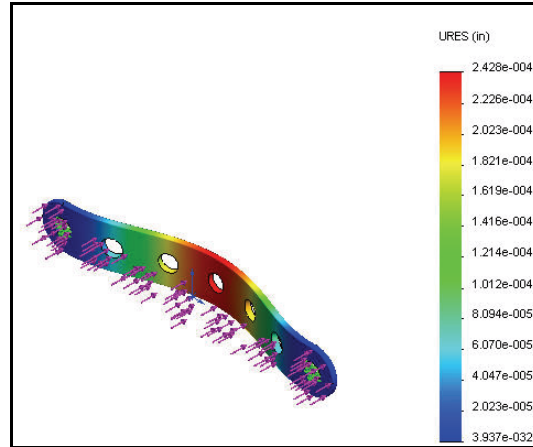

Double-click on the **Factor of Safety** Results folder. View the results in the graphs area. The Flatbar part is displayed in blue and red. Blue is displayed where the FOS is greater than 1.

Does the part deform as you expected? Click **Yes continue**.



The factor of safety of the Flatbar part is approximately 27.0. The FOS indicates that the current design is safe or maybe over designed for the 1lb force applied to the front face with the end holes fixed.

## 2 Modify the factor of safety.

Enter **80** in the Show where factor of safety (FOS) is below box.

Click the **Show where factor of safety (FOS) is below** box.

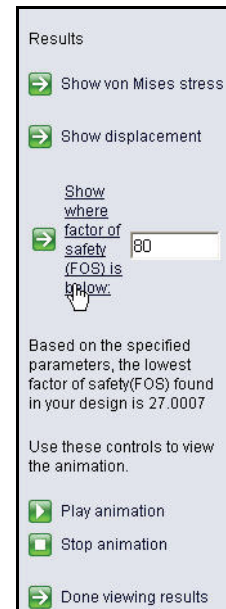

The following plot is displayed. Regions in blue have factors of safety greater than 80.

Regions in red have factors of safety less than 80. The Flatbar part is presently safe with a 1 lb force load. Can we reduce material thickness and still maintain a safe FOS? Let's see.

Click **Done viewing the results**.

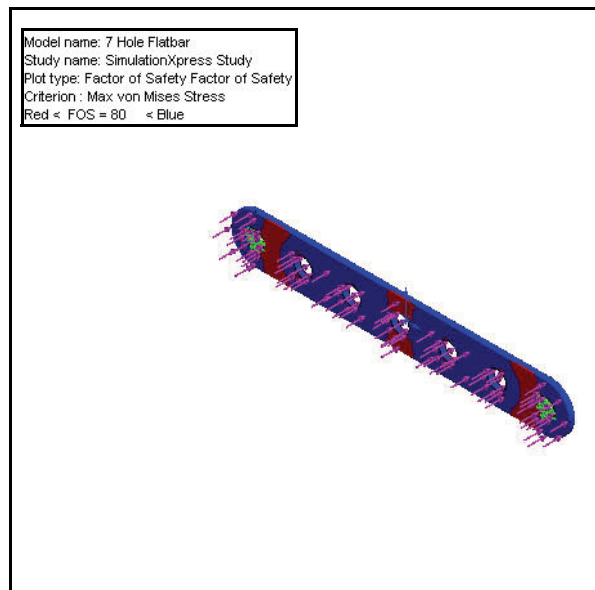

## Running a Report

SolidWorks SimulationXpress provides the ability save a report of your results. This ensures the information is well documented for future work on this or similar projects.

Choose between these two report methods:

- Generate a report (Word document)
- Generate eDrawings file

- 1 **Do not run a report as this time.**  
Click **Next**.

**Note:** As an exercise, create a report.

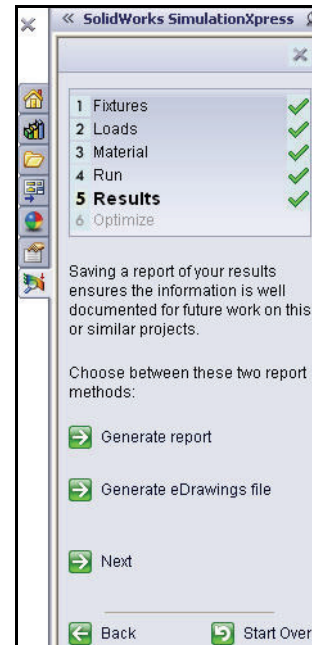

### Optimizing the Model

SolidWorks SimulationXpress tries to find the optimal value for one model dimension while satisfying a specified criterion:

- Factor of Safety
- Maximum Stress
- Maximum displacement

You can either input your desired Factor of Safety or allow SimulationXpress to calculate Factor of Safety based on the upper and lower limits dimension limits.

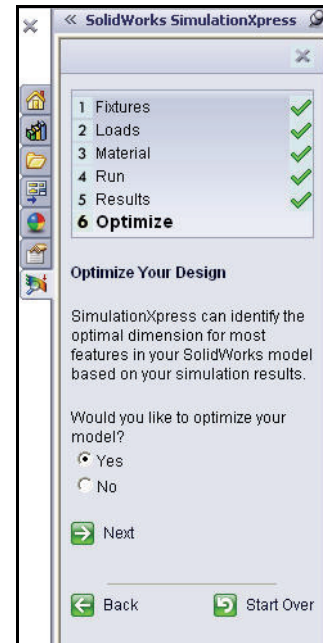

### Optimizing the Model

**1 Optimize the model.**

Accept the default value. Click **Next**.

Click the **.060**[1.52] dimension as illustrated in the graphic area.

Click **OK** from the Add Parameters dialog box

A dimension range is displayed for the thickness of the part. Accept the default range:

Min: = **0.03in**

Max: = **0.09in**.

Click **Next**.

Click **Next**.

**Note:** As an exercise, modify the part material and re-run the analysis.

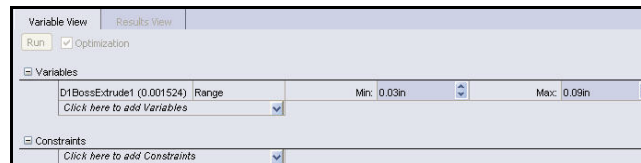
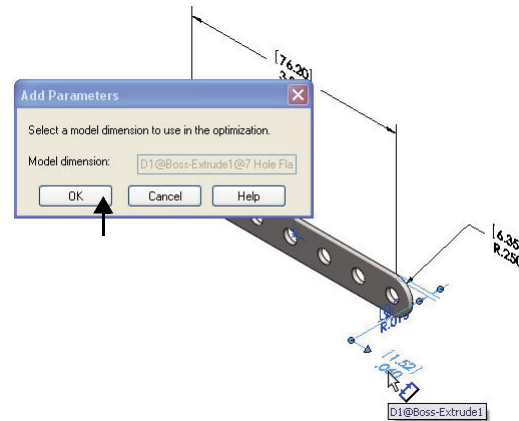
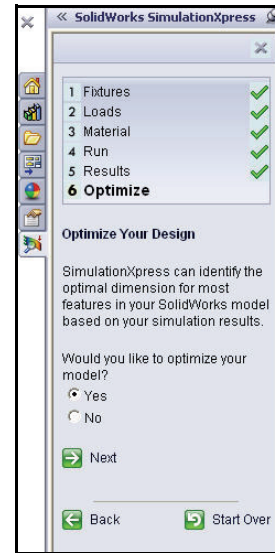

## SolidWorks

## Analyzing the Trebuchet

Specify the minimum Factor of Safety for a thickness.

Click **Specify the constraint**.

Select **Factor of Safety** from the Constraint drop-down menu. View the results.

Click **Next**.

Enter **5** in the Min: column as illustrated.

Click **Next**.

Click **Run the optimization**.

View the results. You can modify material and loads to address various FOS.

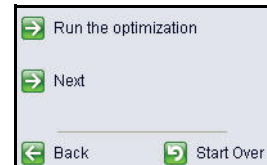
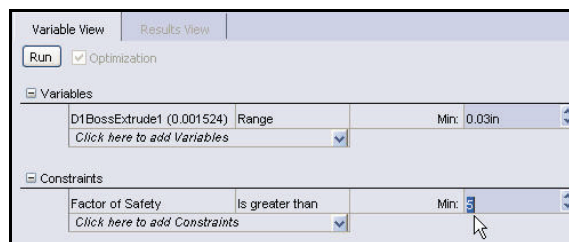
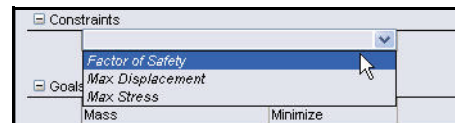
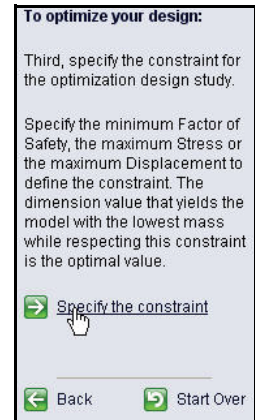

	Initial	Optimal
D1BossExtrude1	0.06in	0.03in
Factor of Safety	27.000742	6.932609
Mass	1.46744e-006 kg	7.3106e-007 kg

## Saving Analysis Data and Closing SimulationXpress

### 1 Save the model.

- Click **Isometric**  view.

Click **Save** . As an exercise, modify the material or load and re-run the analysis to compare results.

### 2 Close all models.

- Click **Window, Close All** from the Menu bar toolbar.

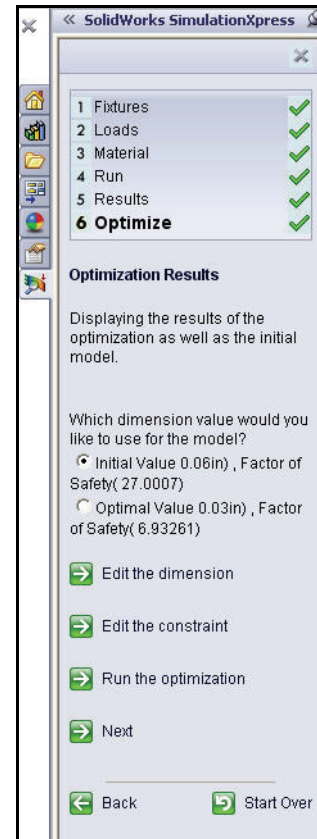

## SolidWorks Motion

SolidWorks Motion is designed for mechanical system simulation. SolidWorks Motion ensures that a design works before it is built.

SolidWorks Motion enables you to:

- Provides confidence that your assembly performs as expected without parts colliding while the components move.
- Increases the efficiency of your mechanical design process by providing mechanical system simulation capability within the familiar SolidWorks environment.
- Uses a single model, without transferring geometry and other data from application to application.
- Eliminates the expense caused by design changes late in the manufacturing process.
- Speeds the design process by reducing costly design change iterations.

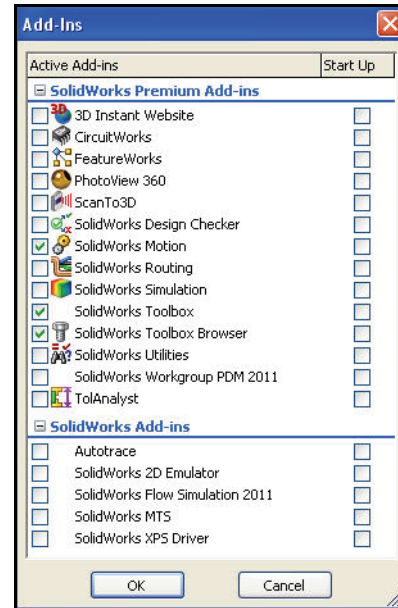

## Starting a SolidWorks Motion session

- 1 **Activate SolidWorks Motion.**
  - Click **Add-Ins.** from the Consolidated Menu bar toolbar. The Add-Ins dialog box is displayed.
  - Check the **SolidWorks Motion** box.
  - Click **OK.**
- 2 **Open the Motion Model assembly.**
  - Click **Open**  from the Menu bar toolbar.
  - Double-click **Motion Assembly** from the **SolidWorks-Trebuchet/ SolidWorks Motion** folder. The Motion Assembly is displayed in the Graphics window.

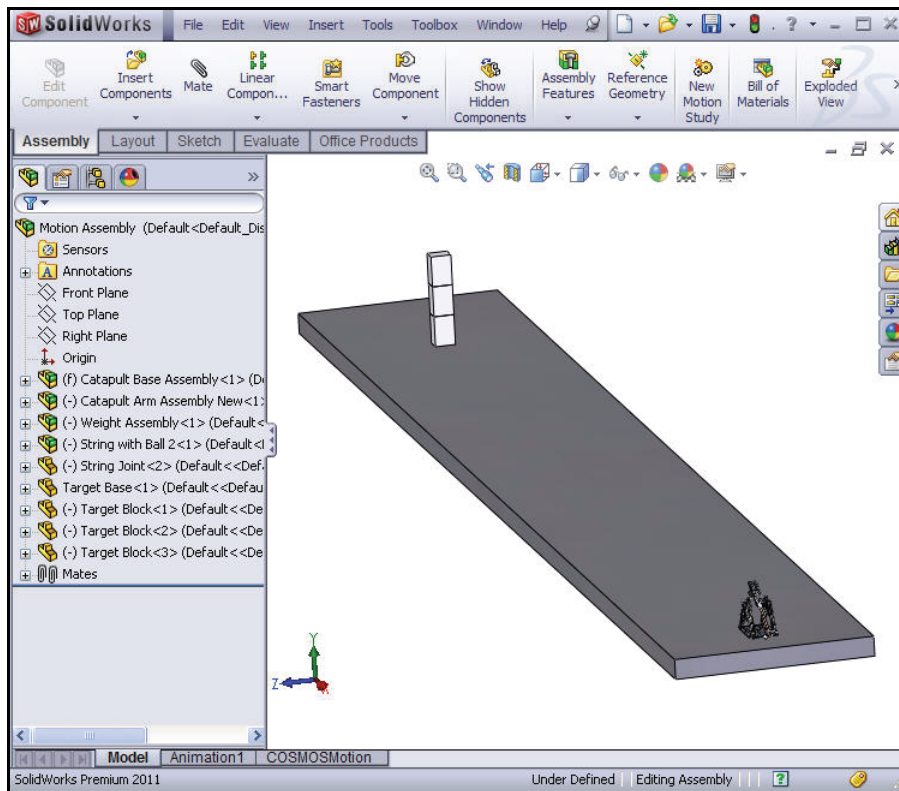
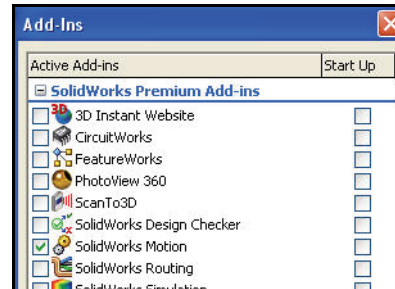
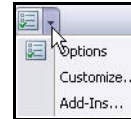

### 3 Play the animation.

- Click the **COSMOSMotion** tab at the bottom of the Graphics window.
- Click the **Play** button. View the virtual simulation.

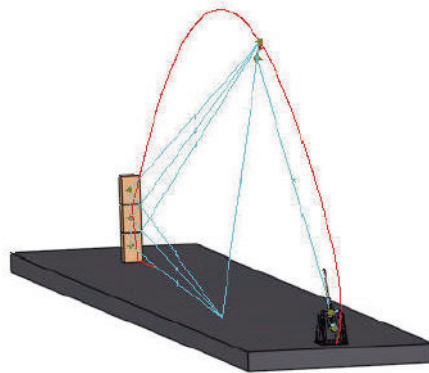
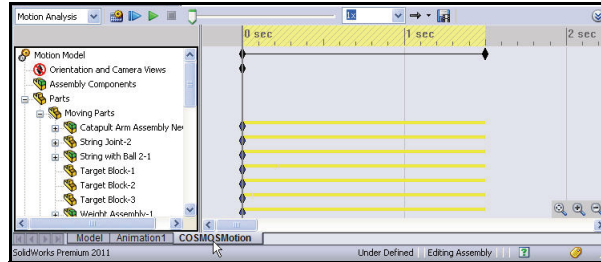

### 4 Return to the Assembly FeatureManager and close all models.

- Click the **Model** tab at the bottom of the Graphics window.
- Close all documents. Click **Window, Close All** from the Menu bar toolbar. You are finished in this section.

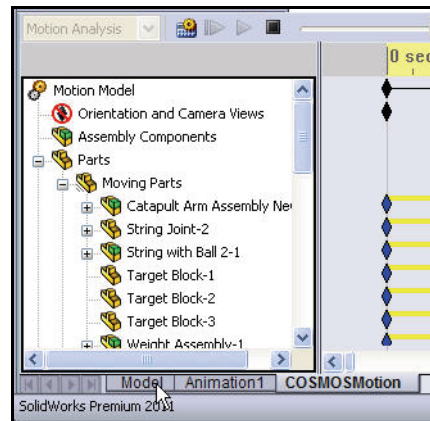

## Conclusion

During this short session on using SolidWorks SimulationXpress and SolidWorks Motion, you have had a brief exposure to the main concepts of analysis. The ease-of-use of SolidWorks SimulationXpress and SolidWorks Motion allows designers to conduct up front analysis on part designs directly in SolidWorks.

The results of analyses are used to drive changes in geometry or material selection allowing you to test many options quickly. Analysis therefore helps you optimize your designs, minimize the cost, and reduce the time-to-market.

While SolidWorks SimulationXpress analyzes parts only, SolidWorks Motion is an analysis program that analyzes assemblies and performs design simulations.

## Lesson 5

# Creating a Trebuchet Drawing

When you complete this lesson, you will be able to:

- Create a multi-sheet drawing.
- Save a drawing.
- Insert a Front, Top, Right, and Isometric view.
- Move and hide drawing dimensions.
- Modify a view scale.
- Add a Sheet to a drawing.
- Insert dimensions into a drawing.
- Add a view dimension.
- Add Notes and Annotations to a drawing.
- Create an Exploded view.
- Generate a Bill of Materials.
- Modify a Bill of Materials.
- Insert Balloons into a drawing view.
- Modify the Title block.
- Create an eDrawing.
- Save an eDrawing.

## Drawings

SolidWorks allows you to easily create drawings of parts and assemblies. Drawings are fully associative with the parts and assemblies they reference. If you change a dimension on a drawing, that change propagates back to the model. Likewise, if you change the model, the drawing updates automatically.

Drawings communicate three things about the objects they represent:

- Shape: Views communicate the shape of an object in a drawing.
- Size: Dimensions communicate the size of an object.
- Other information: Notes communicate nongraphic information about material type, material finish, special manufacturing procedures or considerations, preferred supplier, etc.

### Creating a Drawing – General Procedure

1. Open the part or assembly you wish to detail.
2. Open a new drawing of the desired size.
3. Add views; usually three standard views plus any specialized named views such as detail, auxiliary, or exploded.
4. Insert the dimensions and arrange the dimensions on the drawing.
5. Add additional sheets, views, and notes if required.

### Opening the 7 Hole Flatbar Part

#### 1 Open the 7 Hole Flatbar part.

- Click **Open**  from the Menu bar toolbar.
- Select the **SolidWorks-Trebuchet** folder.
- Select **Part** for Files of type.
- Double-click **7 Hole Flatbar**. The 7 Hole Flatbar part is displayed in the Graphics window. View the Boss-Extrude1, Cut-Extrude1, LPattern1, and Fillet1 features that you created in Lesson 2.

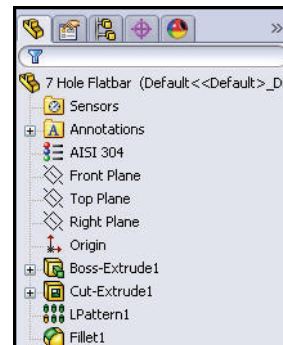

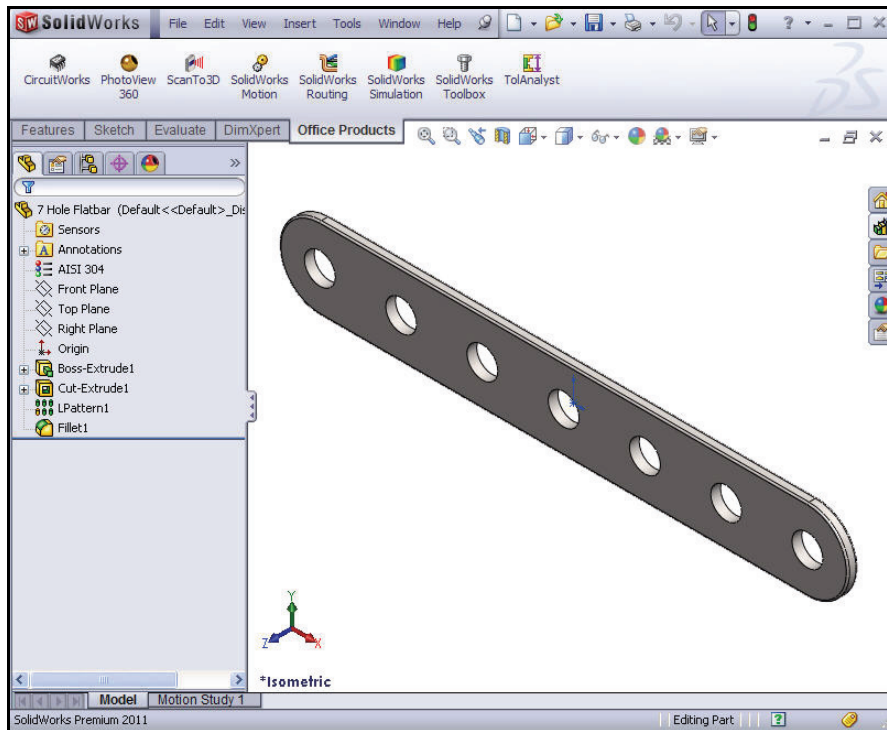

## Creating a Part Drawing

### 1 Create a part drawing.

- Click **New**  from the Menu bar toolbar.
- Double-click **Drawing** from the default Templates tab.
- Click **A (ANSI) Landscape**.
- Check **Standard sheet size**.
- Click **OK** from the Sheet Format/Size dialog box.

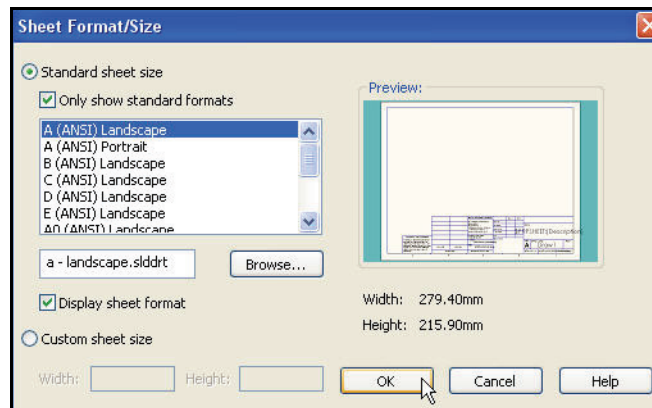
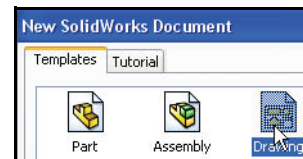

## Creating a Trebuchet Drawing

## SolidWorks

The A (ANSI) Landscape paper is displayed in the new Graphics window. The sheet border defines the drawing size, 11in. x 8.5in.[279.4 x 215.9].

The View Layout and Annotation tab is displayed in the CommandManager.

Draw1 is the default drawing name. Sheet1 is the default first sheet name.

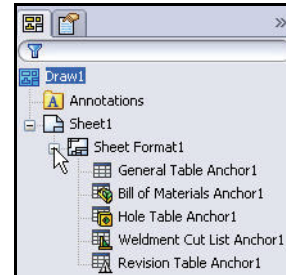

### 2 Close the Model View PropertyManager.

- If you see the Model View PropertyManager, Click the **Cancel**  tool from the Model View PropertyManager. View the Draw1 FeatureManager.



### 3 Set Third Angle Projection.

- **Right-click** in the Graphics window.
- Click **Properties**.
- Click the **Third angle** box for Type of projection.
- Click **OK** from the Sheet Properties dialog box.

**Note:** Third Angle Projection is used in the Lesson.

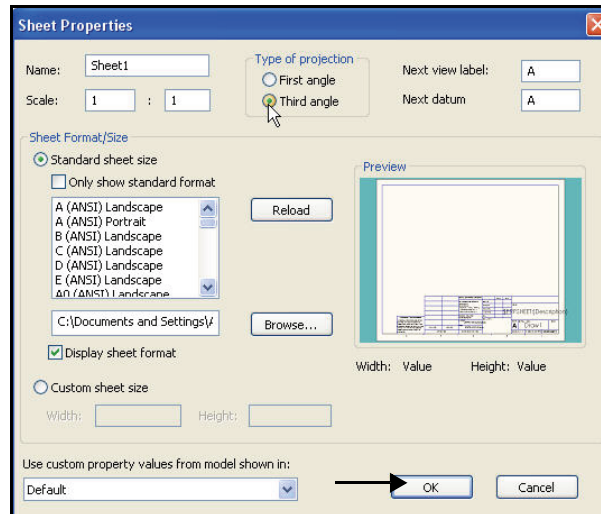

**Tip:** A New Drawing invokes the Model View PropertyManager if the Start command when creating new drawing option is checked.

**4 Set Drafting Standard.**

- Click **Options**  **Document Properties** tab from the Menu bar toolbar. The Document Properties - Drafting Standard dialog box is displayed.

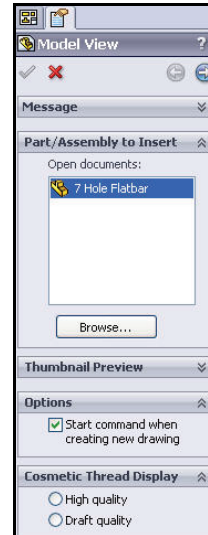

- Select **ANSI** for Overall drafting standard.

**5 Set unit system and length.**

- Click **Units**.
- Click **IPS** (inch, pound, second) for Unit system.
- Select **.123** for Length unit decimal place.
- Select **None** for Angle decimal place.
- Select **millimeters** for Dual Dimension Length.

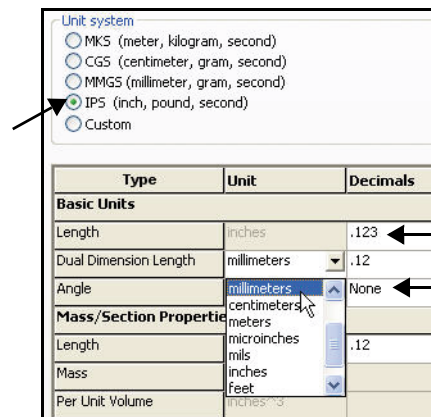
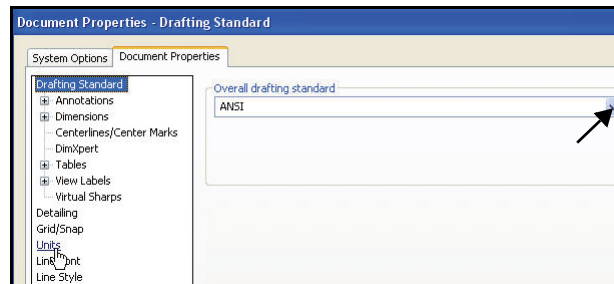

- 6 **Set dual unit display.**
  - Click **Dimensions** from the Document Properties dialog box.
  - Check the **Dual dimensions display** box.
- 7 **Set System options.**
  - Click **OK** from the Document Properties-Dimensions dialog box.

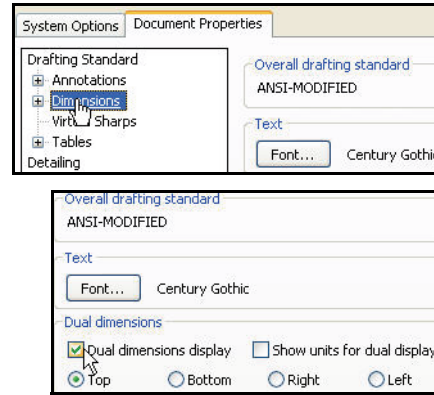

**Note:** Detailing options provide the ability to address:

- Dimensioning standards.
- Text style.
- Center marks.
- Extension lines.
- Arrow styles.
- Tolerance.
- Precision.

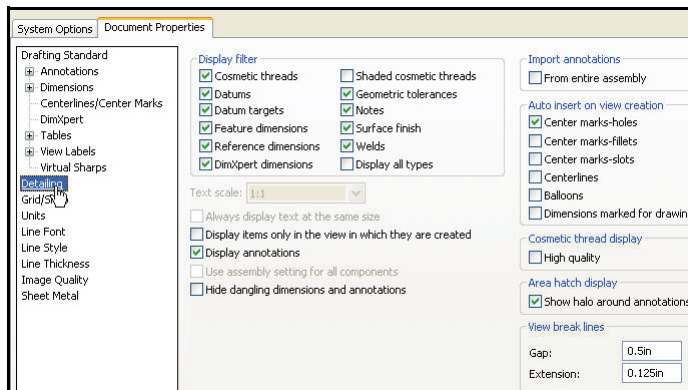

There are numerous text styles and sizes available in SolidWorks. Companies develop drawing format standards and use specific text height for Metric and English drawings.

- 8 **Insert the 7 Hole Flatbar.**
  - Click the **View Layout** tab from the CommandManager.
  - Click the **Model View** tool from the View Layout toolbar. The Model View PropertyManager is displayed.
  - Click **7 Hole Flatbar** from the Open documents box.

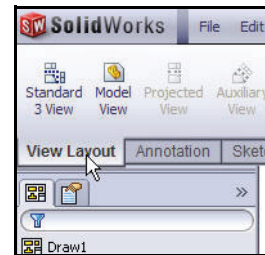

- Click **Next** . Drawing view names are based on the part view orientation. The Front view is the first view inserted into the drawing. The Top and Right views are projected from the Front view.

The Model View PropertyManager provides various options. The key option boxes used in this lesson are:

- **Create multiple views box**  
This option lets you select a Single view or Multiple views for the drawing. Single view is activated by default.
- **Orientation box - Standard views**  
This option contains a representation of all the views that are defined in the part or assembly. Tool tips display the view name.

Select Preview to view a preview of the view as you position it on the drawing. When this option is cleared, only the outline of the view boundaries is displayed.

- **Display Style box**  
This option allows the user to display drawing views such as; Wireframe, Hidden Lines Visible, Hidden Lines Removed, Shaded With Edges, & Shaded.
- **Scale box**  
This option allows you to control the scale of the drawing views.

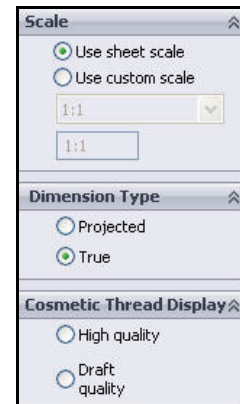
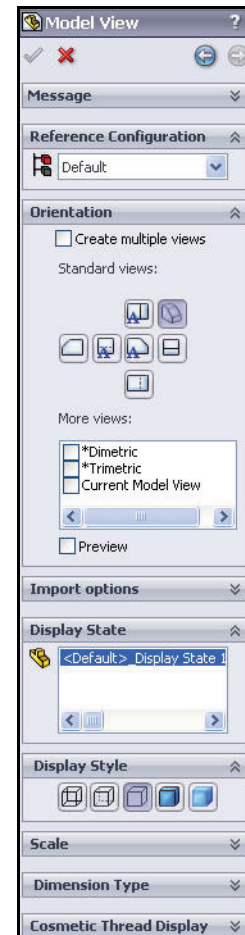





## Inserting an Isometric View using the View Palette

Pictorial views such as an Isometric view make drawings easier to read and visualize. Because SolidWorks models are true three-dimensional solids, creating pictorial views is as simple as the click of the mouse.

### 1 Insert an Isometric view.

- Click the **View Palette**  tab from the Task Pane.
- Select **7 Hole Flatbar** from the View Palette drop-down menu.
- Drag and drop the **\*Isometric** view into Sheet1 as illustrated.
- Click **Shaded** from the Display Style dialog box.
- Click **OK**  from the Drawing View4 PropertyManager. Drawing View4 is added to the 7 Hole Flatbar Drawing FeatureManager.

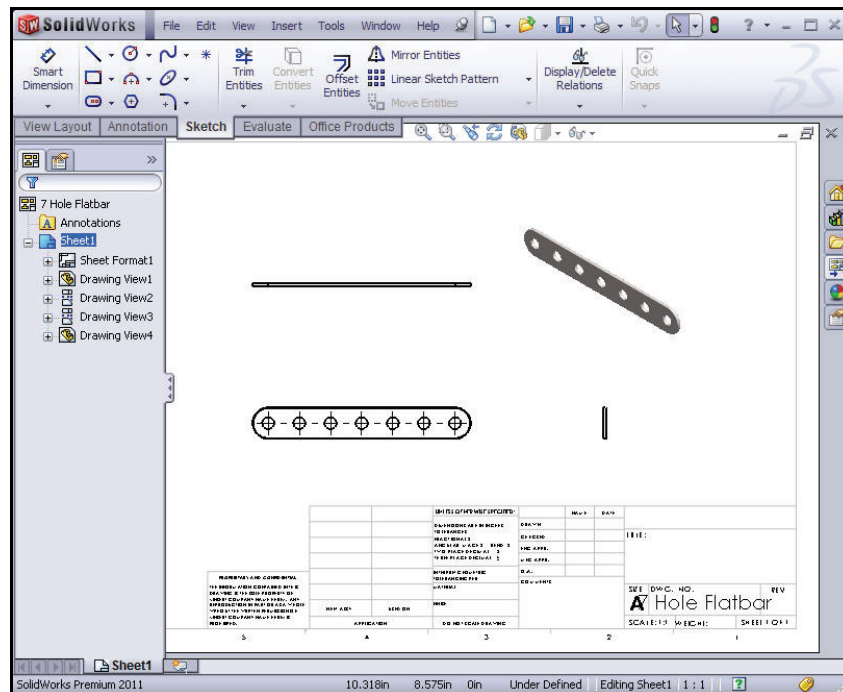
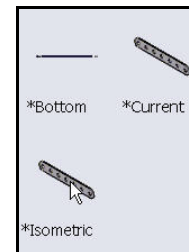
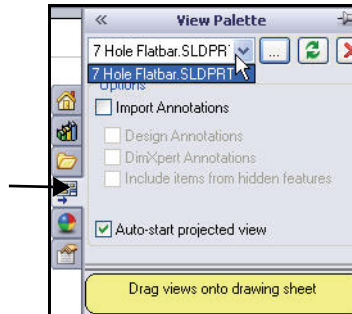

### Saving the Drawing

Drawing files have the .slddrw extension. A new drawing takes the name of the first model inserted. The name appears in the title box.

**1 Deactivate the Origins and save the drawing.**

- If needed, deactivate the Origins. Click **View**, un-check **Origins** from the Menu bar menu.
- Click **Save** . Accept the defaults.
- Click **Save** from the Save As box. The 7 Hole Flatbar drawing FeatureManager is displayed.

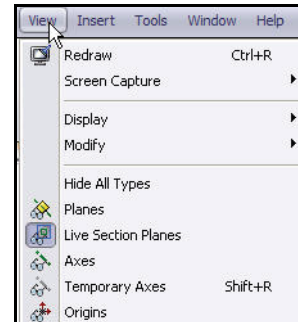

### Drawing View Display

Views can be displayed in several ways: **Wireframe**, **Hidden Lines Visible**, **Hidden Lines Removed**, **Shaded With Edges**, and **Shaded**. The following illustration shows the ways in which models can be displayed in a drawing.

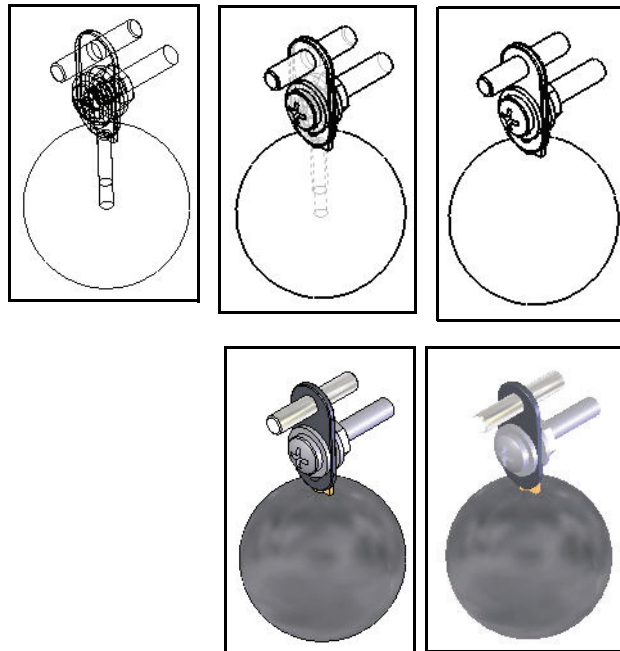

## Drawing Modes

There are two drawing modes types:

- Edit Sheet Format.
- Edit Sheet.

The Edit Sheet Format mode provides the ability to:

- Change the Title block size and text headings.
- Incorporate a company logo.
- Add or modify text.



The Edit Sheet mode provides the ability to:

- Add or modify views.
- Add or modify dimensions.
- Add or modify text.

### 1 Activate the Edit Sheet Format mode.

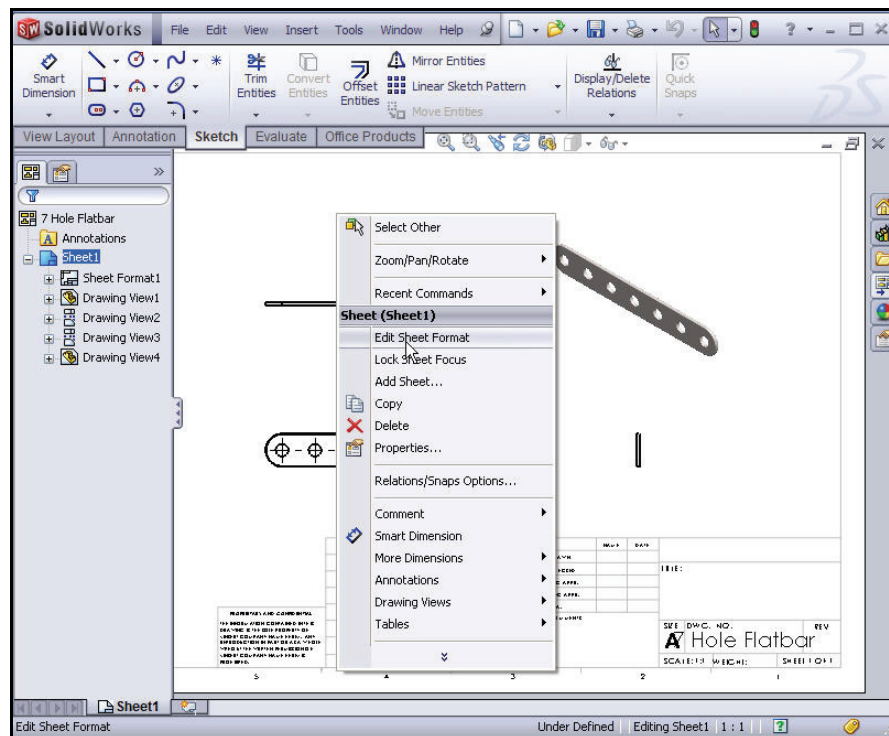
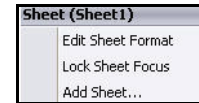
- Right-click inside the **Graphics window**.
- Click **Edit Sheet Format**. The Title block lines turn blue.



- Click the **Zoom to Area**  tool.
  - **Zoom in** on the Title block.
  - Click the **Zoom to Area**  tool to deactivate.
- 2 Modify the DWG. NO. font size.**
- Double-click **7 Hole Flatbar** in the DWG. NO. block.
  - Click the **drop-down** arrows to set the Text Font from the formatting dialog box.
  - Select **18** for size from the Formatting box.
  - Click **OK**  from the Note PropertyManager.
- 3 Activate the Edit Sheet mode.**
- Right-click in the **Graphics window**.
  - Click **Edit Sheet**.

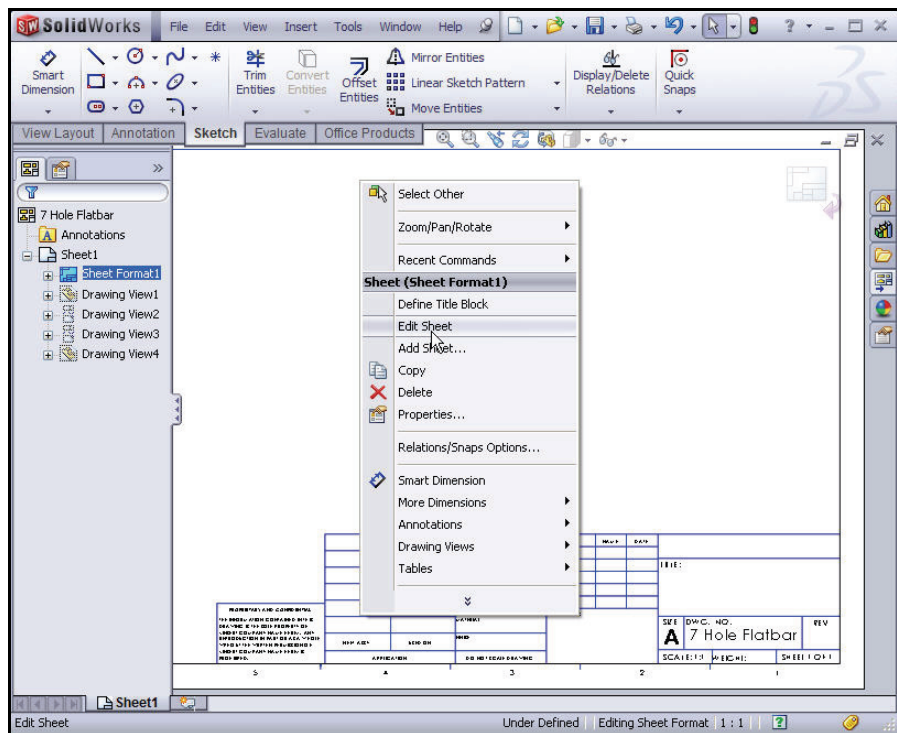
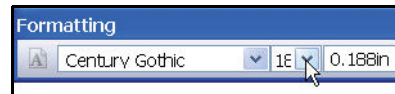
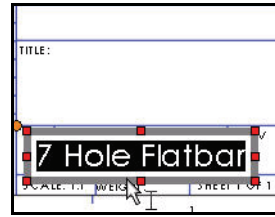

## Moving Drawing Views

Reposition the views on the drawing. Provide approximately 1in[25.4mm] between each view for dimension placement.

### 1 Fit the drawing to the Graphics window.

- Press the **f** key.

### 2 Position views.

- Click a **position** on the Sheet. The mouse pointer displays the Sheet icon.
- Click the **view boundary** of Drawing View1(Front). The mouse pointer displays the Drawing view boundary.
- Click a **position** inside the view boundary of Drawing View1. The mouse pointer displays the view icon.
- Click and drag **Drawing View1** view boundary in an upward vertical direction. Drawing View2 (Top) and Drawing View3 (Right) move aligned to Drawing View1 (Front).

**Note:** If needed deactivate the Origins. Click **View**, un-check **Origins** from the Menu bar menu.

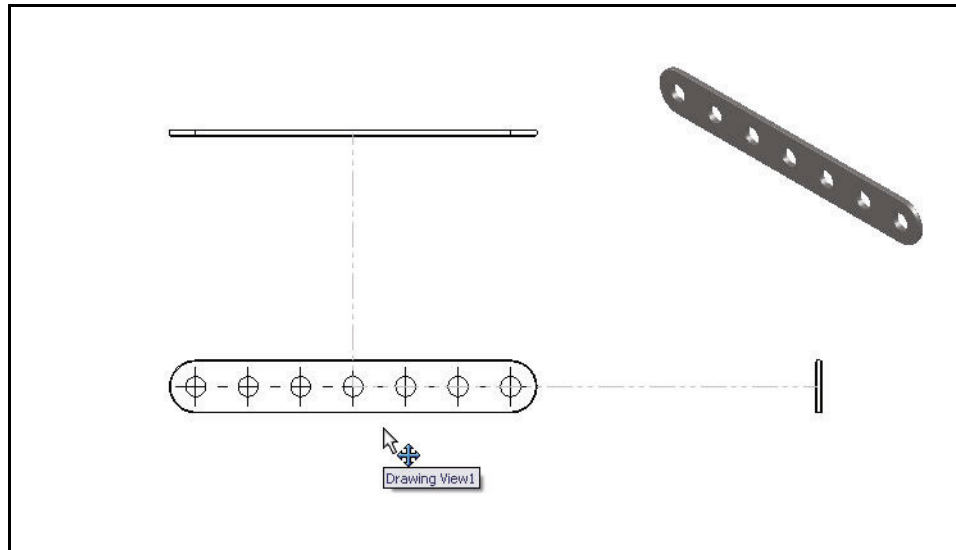
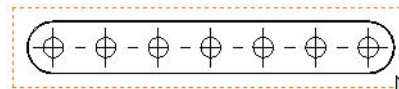
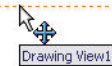
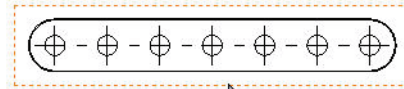
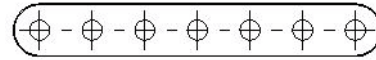

- Press the **Shift + z** keys to Zoom in on Sheet1.
- Move **Drawing View3** in a right to left direction.
- 3 Fit the views to the sheet.**
  - Press the **f** key.
- 4 Save the drawing.**
  - Click **Save** .

## Detailing a Drawing

Detail drawings require dimensions, annotations, tolerance, material, Engineering Change Orders, authorization, etc. to release the part to manufacturing and other notes prior to production.

Insert dimensions and annotations from the part. You will insert dimensions and annotations by selecting individual features, views or the entire sheet.

## Dimensions

Model dimensions are the dimensions and parameters that were used to create the part that is referenced in the drawing. These dimensions are considered driving dimensions. You can use driving dimensions to make changes to the model.

Dimensions generally serve one of two purposes:

- Size dimensions - how big is a feature?
- Location dimensions - where is the feature?



## Dimension Guidelines – Appearance

- Place dimensions away from the profile lines.
- Allow space between individual dimensions.
- A gap must exist between the profile lines and the extension lines.
- The size and style of the leader line, text, and arrows should be consistent throughout the drawing.
- Display only the number of decimal places required for manufacturing precision.

## Inserting Dimensions

Dimensions can be automatically added to the drawing by importing the dimensions from the models that are shown on the drawing.

### 1 Insert dimensions.

- Click the **center** of Sheet1. The mouse pointer displays the Sheet icon.
- Click the **Annotation** tab from the CommandManager.
- Click the **Model Items**  tool from the Annotation toolbar. The Model Items PropertyManager is displayed. The Import items into all views option is checked by default.
- Select **Entire model** from the Source/Destination box.
- Click **OK**  from the Model Items PropertyManager. Dimensions are inserted into the drawing views.

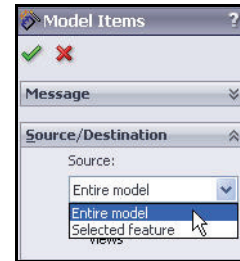
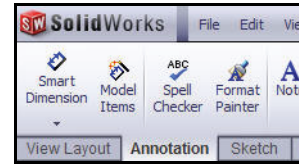

**Note:** The dimensions are not in the correct location with respect to the profile lines. You will move them late in this lesson.

Use the mouse pointer to click and drag dimensions and leader lines to the proper location.

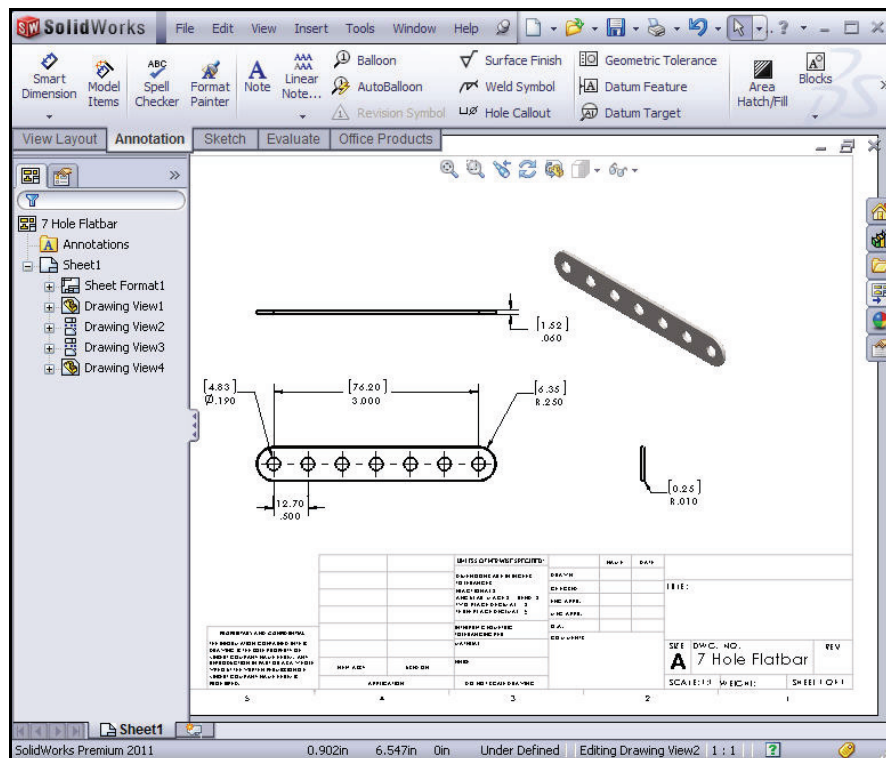

2 Remove the trailing zeroes in the dimensions.

- Click **Options**  **Document Properties** tab from the Menu bar toolbar.
- Click **Dimensions**.
- Select **Remove** for the Trailing zeroes drop-down menu.
- Click **OK** from the Document Properties - Dimensions dialog box. The trailing zeroes are removed from the inserted drawing dimensions.

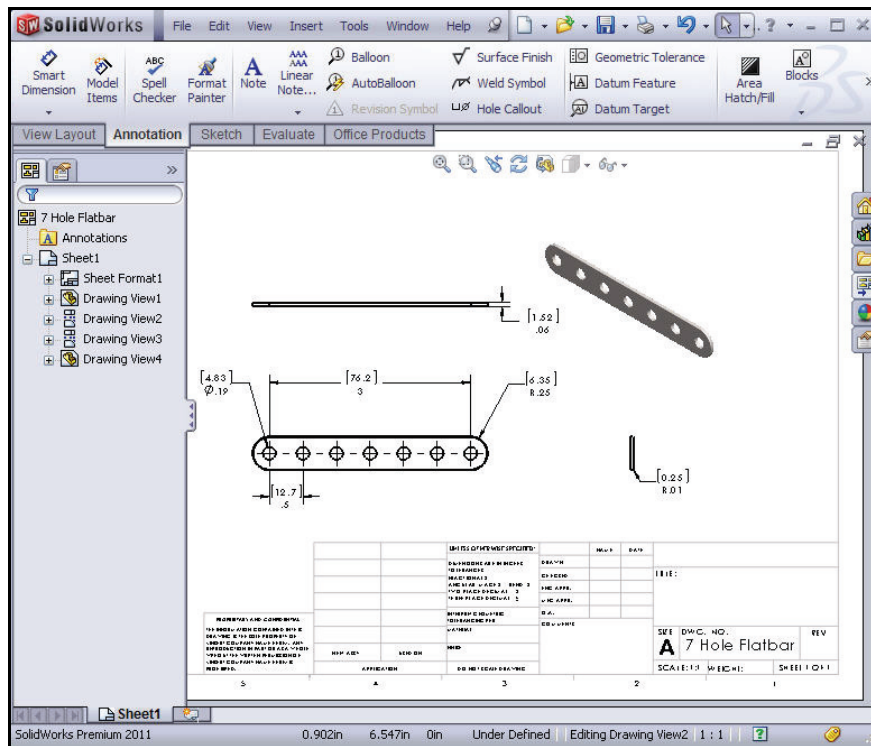
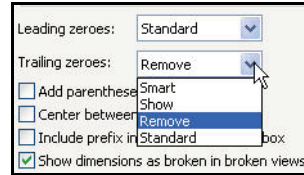

**Note:** The location of the drawing dimensions is dependent on: Feature dimension creation and Selected drawing views.

Leader lines reference the size of the profile. A gap must exist between the profile lines and the leader lines. Shorten the leader lines to maintain a drawing standard

Use the blue Arrow buttons in the Graphics window to flip the dimension arrows.

Plan ahead for general drawing notes. Notes provide relative part or assembly information. Example: Material type, material finish, special manufacturing procedure or considerations, preferred suppliers, etc.

Below are a few helpful guidelines to create general drawing notes:

- Use capitol letters.
- Use left text justification.
- Font size should be the same as the dimension text.

Create Parametric notes by selecting dimensions in the drawing. Example: Specify the Material Thickness of the 7 Hole Flatbar as a note in the drawing. If the thickness is modified, the corresponding note is also modified.

Hide superfluous feature dimensions. Do not delete feature dimensions. Recall hidden dimension with the View, Show Annotations command. Move redundant, dependent views outside the sheet boundary.

### 3 Move the dimensions in Drawing View1, (Front).

- Click dimension text **3[76.2]**. The dimension text turns blue.
- Drag the **dimension text** downward.
- Click dimension text **.5[12.7]**.
- Drag the text approximately **10mm's** from the profile. The smallest linear dimensions are closest to the profile.
- Click the radial dimension text **R.25[6.35]**.
- Drag the **radial dimension text** diagonally off the profile if required.

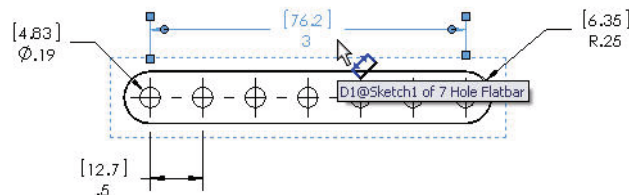
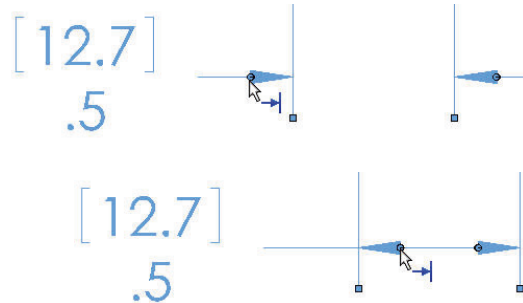

**4 Modify the dimension text.**

- Click diameter dimension text **.19**[4.83]. The dimension is displayed in blue.
- Click inside the **Dimension Text** box.
- Enter **7X** before <MOD-DIAM>.
- Enter **EQ SP** after <DIM>.

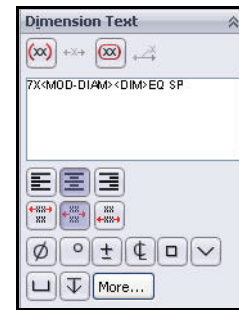
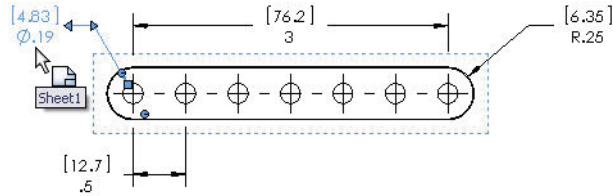

- Click **OK**  from the Dimension PropertyManager. View the results.

**Tip:** Inserted dimensions can be moved from one drawing view to another. Hold the Shift key down. Click and drag the dimension text from the first view into the second view boundary. Release the shift key. Release the mouse button.

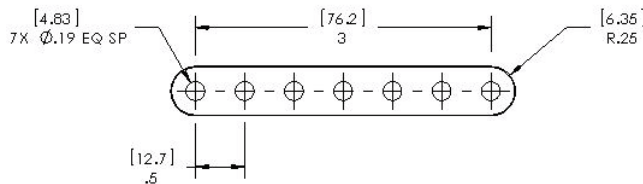

**5 Modify the Precision of the Material Thickness.**

- Click depth dimension text **.06**[1.52] in Drawing View2. The dimension is displayed in blue.

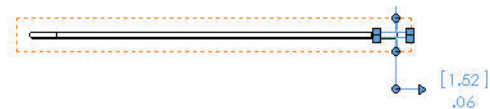

- Select **.1** from the Tolerance/Precision box.

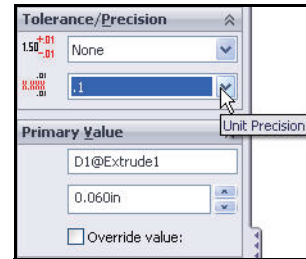

- Click **OK**  from the Dimension PropertyManager. The dimension text displays **.1[1.52]** in the Top view.

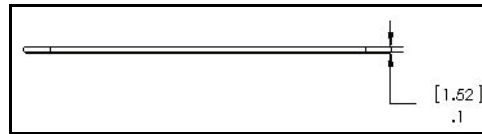

**6 Add a Parametric note.**

- Click the **Note**  tool from the Annotate toolbar.
- Click a **position** above Drawing View1, (Front).
- Enter **MATERIAL THICKNESS**.
- Press the **Space** bar.
- Click the depth dimension text **.1[1.52]** in Drawing View2, (Top). The variable name for the dimension is displayed in the text box.
- Click **OK**  from the Note PropertyManager. View the results.

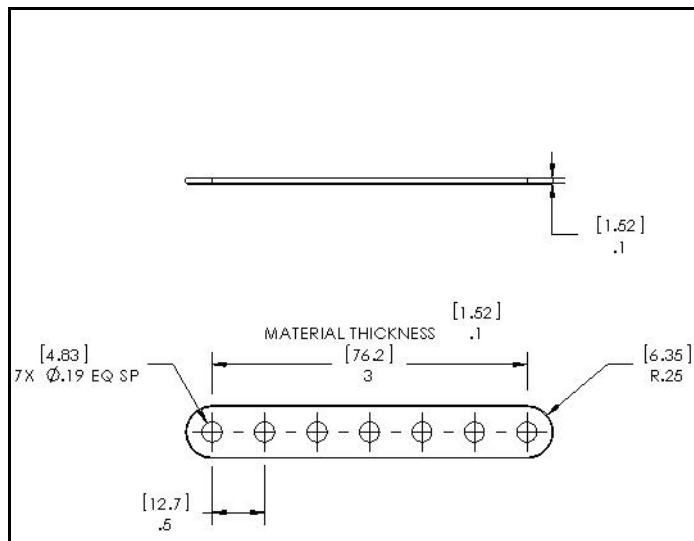
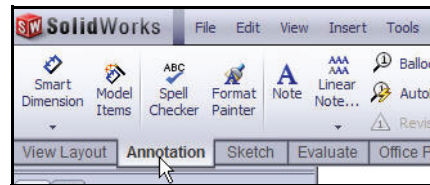

**7 Hide superfluous dimensions.**

- Right-click the .1[1.52] dimension text in Drawing View2.
- Click **Hide**.



**8 Hide Drawing View3, (Right).**

- Right-click **Drawing View3** from the FeatureManager.
- Click **Hide**.

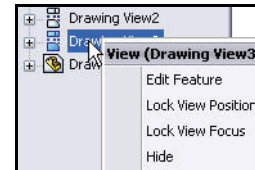

**9 Save the drawing.**

- Click **Save** .

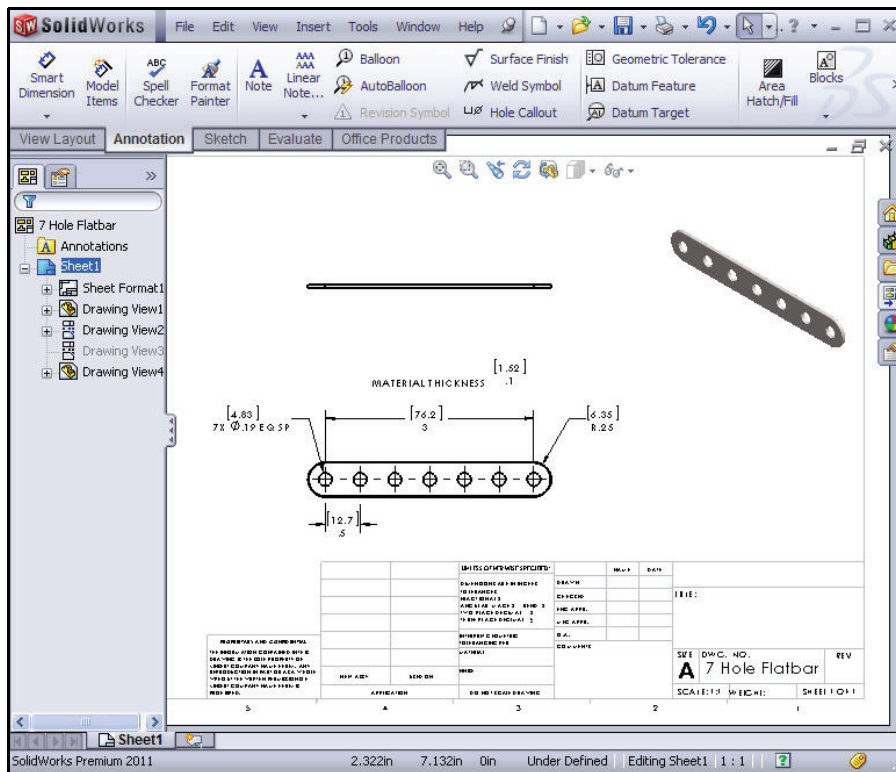



## Associativity

In SolidWorks, everything is associative. If you create a change to a part, the change will propagate to any and all assemblies and drawings that reference that part.

- Changing the values of imported dimensions will change the part.
- You cannot change the values of manually inserted dimensions.
- Changing a dimension on the drawing changes the model.

You will first modify the depth of the 7 Hole Flatbar part. You will then view the depth change in the part and then in the associative 7 Hole Flatbar drawing. You will then return the depth of the part to its original dimension.

### 11 Modify the depth of the 7 Hole Flatbar.

- Right-click inside the **Drawing View1** view boundary.

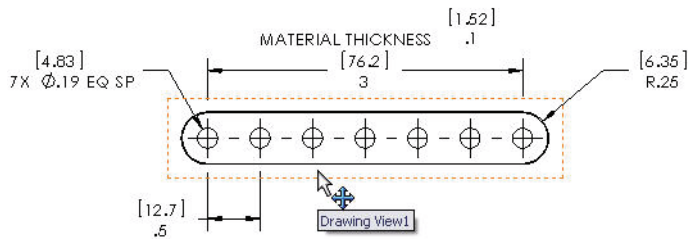

- Click **Open Part**. The 7 Hole Flatbar part is displayed in the Graphics window.

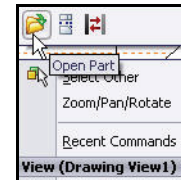

- Click **Boss-Extrude1** from the 7 Hole Flatbar FeatureManager.

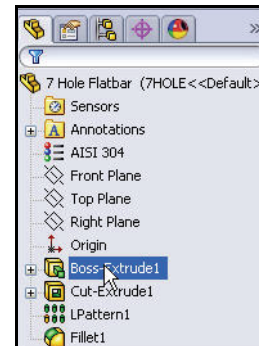

**SolidWorks**

**Creating a Trebuchet Drawing**

- Click the **.060**[1.52] dimension text.
  - Enter **0.200**[5.08].
- 12 Return to the drawing.**
- Click **Window, 7 Hole Flatbar - Sheet1** from the Menu bar toolbar. The 7 Hole Flatbar drawing references the modified dimension of .2 [5.08] for MATERIAL THICKNESS.

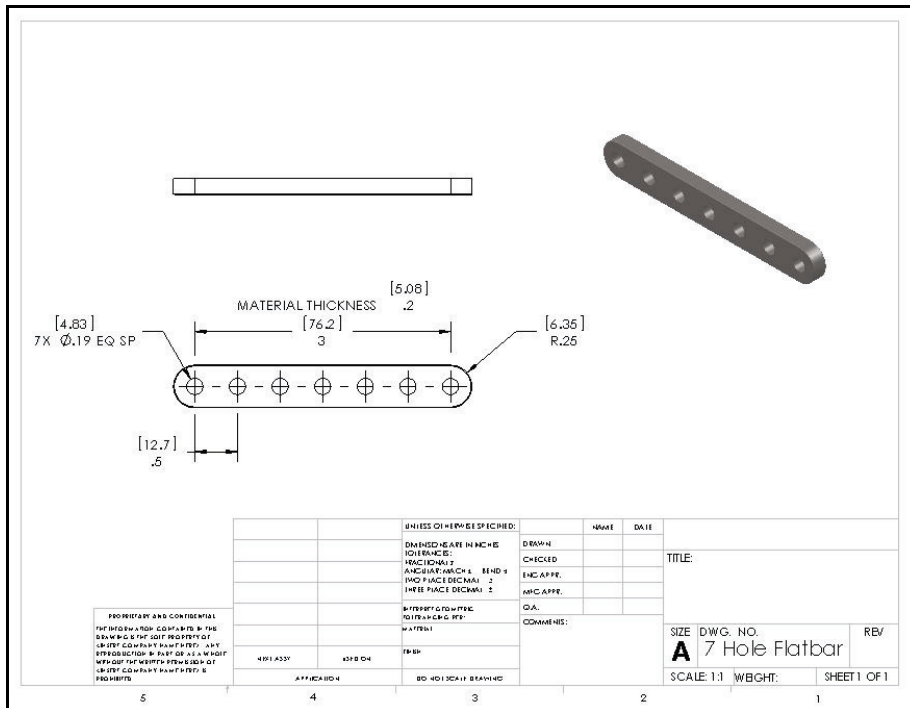
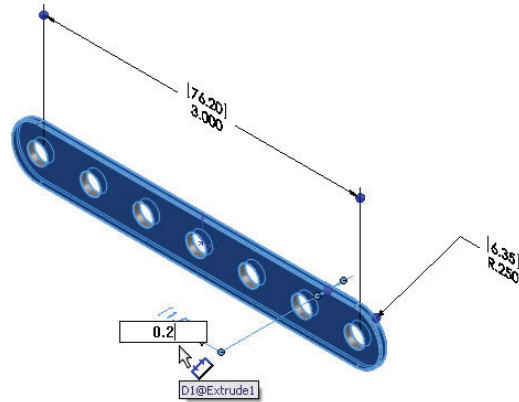

- 13 Return to the 7 Hole Flatbar part.
  - Click **Window, 7 Hole Flatbar** from the Menu bar toolbar.
  - Click **Boss-Extrude1** from the 7 Hole Flatbar FeatureManager.
  - Click the **.200**[5.08] dimension text.
  - Enter **.060**[1.52].
  - Click **inside** the Graphics window.
- 14 Return to the drawing.
  - Click **Window, 7 Hole Flatbar-Sheet1** from the Menu bar toolbar.

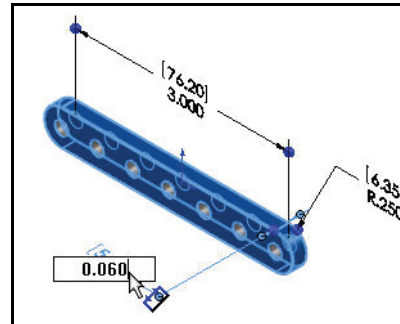

The 7 Hole Flatbar drawing references the modified dimension of .1in[1.52mm] for MATERIAL THICKNESS.

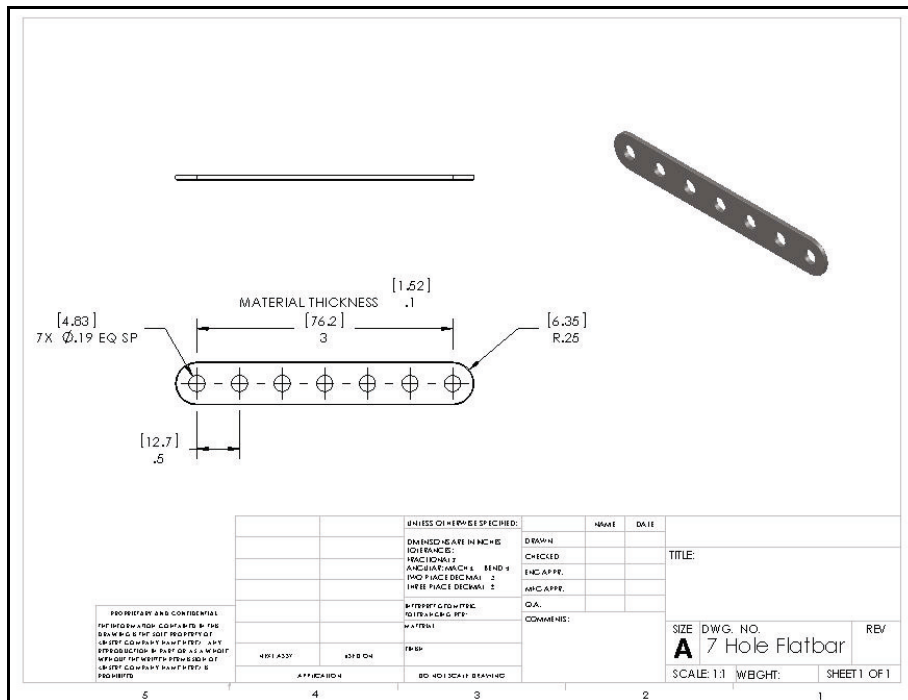

Do not delete the part or move the part location. Work between multiple documents:

- Press Ctrl-Tab to toggle between open SolidWorks documents.
- Right-click inside the Drawing view boundary. Select Open Part. Example: Open 7 hole flatbar.sldprt.

- Right-click the part icon in the FeatureManager. Select Open Drawing.
  - Commands are accessed through the Toolbars and Menus. Commands are also accessed with a Right-click in the Graphics window and FeatureManager.
- A majority of the 7 Hole Flatbar drawing dimensions are inserted from the 7 Hole Flatbar part. An overall dimension is required to dimension the slot shape profile.

## Adding a Dimension

### 1 Add an overall dimension in Drawing View1.

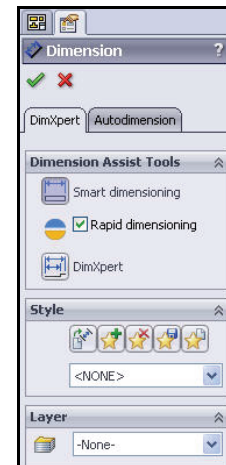
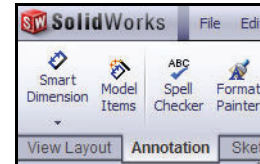

- Click the **Smart Dimension**  tool from the Annotation toolbar. The Dimension PropertyManager is displayed. Smart dimensioning is the default option.

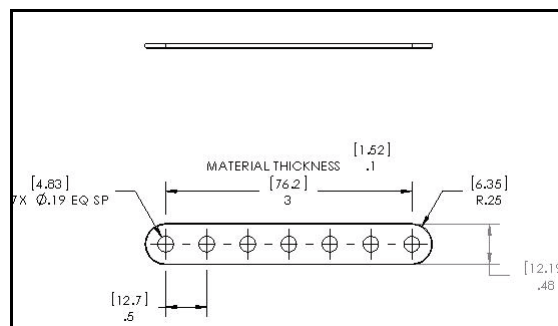

- Click the **top horizontal** line in Drawing View1.
- Click the **bottom horizontal** line in Drawing View1.
- Click a **position** to the right of Drawing View1 as illustrated.
- If needed, un-check the **Add Parenthesis** box in the Dimension Text box.
- Click **OK**  from the Dimension PropertyManager. View the new .48[12.19] dimension.



### Modifying the Radius Text

- 1 **Modify the radius text.**
  - Click the **R.25**[6.35] dimension text.
  - Delete **R<DIM>** in the Dimension Text box.
  - Click **Yes** to the Overriding dimension text value question.
  - Enter **2X R** for Dimension text. Do not enter the radius value.
  - Click **OK**  from the Dimension PropertyManager.
- 2 **Insert dimension gaps.**
  - Insert **gaps** as illustrated.
- 3 **Save the drawing.**
  - Click **Save** .
  - Click **Save All**.

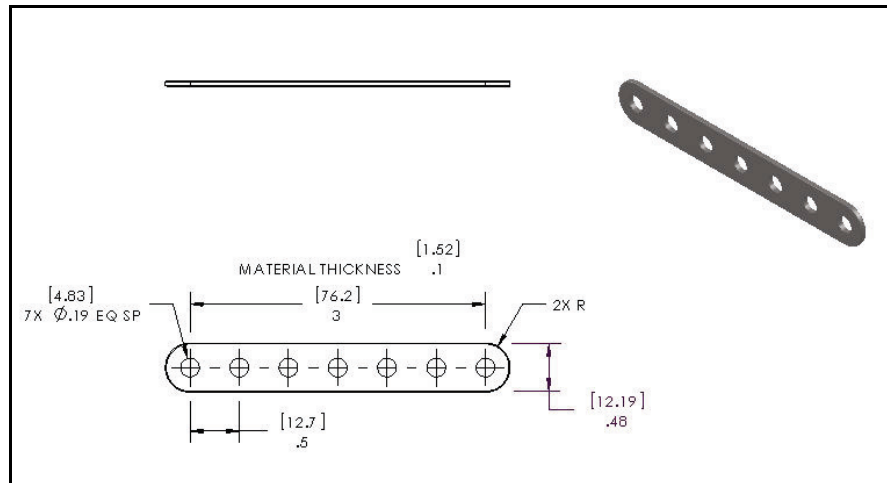
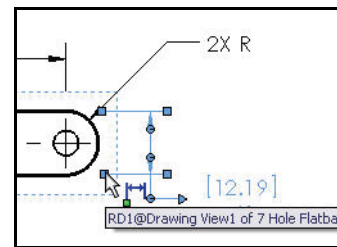
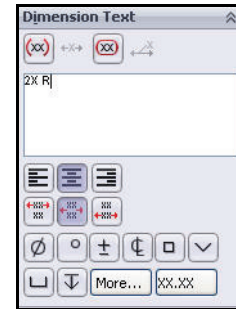

## Creating a Design Tables.

A Design Table is a spreadsheet used to create multiple configuration in a part or assembly. The Design Table controls the dimensions and parameters in the part. Utilize the Design Table to modify the overall length and number of the holes in each Flatbar configuration.

Create three Flatbar configurations:

- 3 Hole
- 5 Hole
- 9 Hole

Utilize the Design Table to control the Part Number and Description in the Bill of Materials.

### 1 Open the 7 Hole Flatbar part.

- Click **Window, 7 Hole Flatbar** from the Menu bar toolbar. The 7 Hole Flatbar part is displayed.

### 2 Insert a Design Table.

- Click **Insert, Tables, Design Table** from the Menu bar menu. The Auto-create option is selected by default.

- Click **OK**  from the Design Table PropertyManager. The Dimensions box and the Excel spread sheet is displayed.

### 3 Select the input dimensions.

- Hold the **Ctrl** key down.
- Click **D1@Sketch1, D2@Sketch1, D1@Boss-Extrude1, D1@Sketch2, D3@LPattern1, D1@LPattern1** and **D1@Fillet1** from the Dimensions box.
- Release the **Ctrl** key.
- Click **OK** from the Dimensions dialog box.

**Note:** The dimension names and default values are automatically entered into the Design Table. The Design Table displays the Primary Units of the Part. Example: Inches. Default is entered in Cell A3.

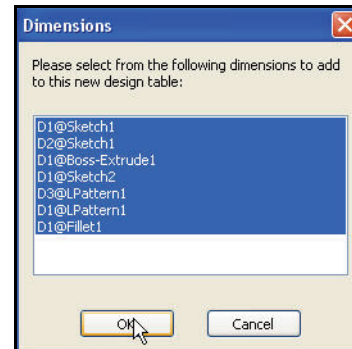
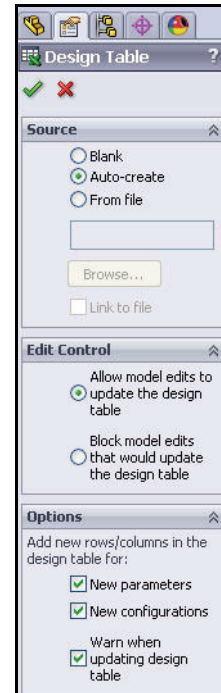

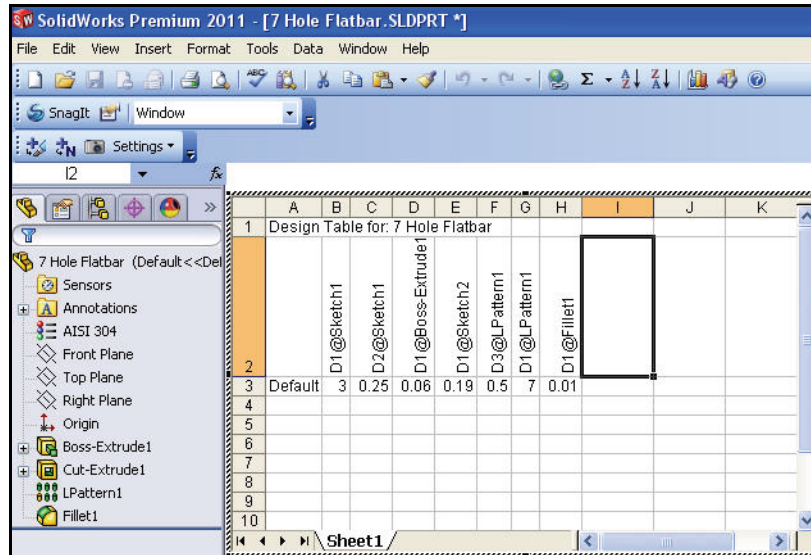

**4 Enter the three configuration names.**

- Click Cell A4.
- Enter 3Hole.
- Click Cell A5.
- Enter 5Hole.
- Click Cell A6.
- Enter 9Hole.

**5 Modify the Flatbar thickness.**

- Click Cell D3.
- Enter 0.09[2.29].

**6 Enter the dimension values for the 3Hole configuration.**

- Click Cell B4.
- Enter 1[25.4].
- Click Cell G4.
- Enter 3.

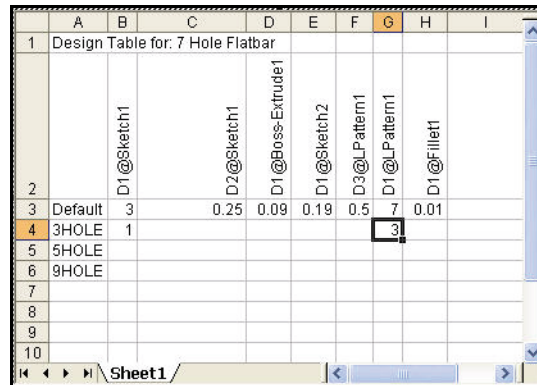

**7 Enter the dimension values for the 5Hole configuration.**

- Click Cell **B5**.
- Enter **2**[76.2].
- Click Cell **G5**.
- Enter **5**[127].

**8 Enter the dimension values for the 9Hole configuration.**

- Click Cell **B6**.
- Enter **4**[101.6].
- Click Cell **G6**.
- Enter **9**[228.6].

	A	B	C	D	E	F	G	H	I
1	Design Table for: 7 Hole Flatbar								
2		D1@Sketch1		D2@Sketch1	D1@Boss-Extrude1	D1@Sketch2	D3@LPattern1	D1@LPattern1	D1@Fillet1
3	Default	3	0.25	0.09	0.19	0.5	7	0.01	
4	3HOLE	1					3		
5	5HOLE	2					5		
6	9HOLE	4					9		
7									
8									
9									
10									

**9 Build the three configurations.**

- Click a **position** outside the EXCEL Design Table in the Graphics window.
- Click **OK** to generate the configuration.



**Note:** The Design Table icon is displayed in the 7 Hole Flatbar ConfigurationManager.

**10 Display the Flatbar configurations.**

- Click the **ConfigurationManager**  tab.
- Double-click **3Hole**. View the model.
- Double-click **5Hole**. View the model.
- Double-click **9Hole**. View the model.
- Double-click **Default [7 Hole Flatbar]**.

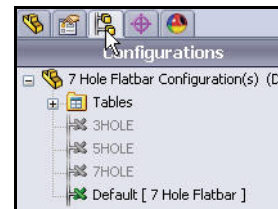

**11 Save the model.**

- Click **Save** .

**12 Edit the Design Table.**

- **Expand** the Tables folder.
- Right-click **Design Table** from the 7 Hole Flatbar ConfigurationManager.
- Click **Edit Table**.

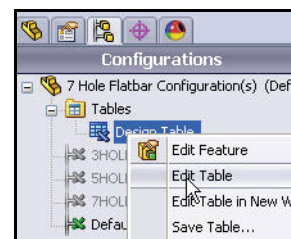

## Creating a Trebuchet Drawing

## SolidWorks

- Click **Cancel** from the Add Rows and Columns box. Columns C through H are filled with the default 7 Hole Flatbar values.

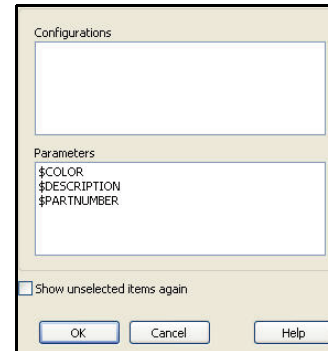

	A	B	C	D	E	F	G	H	I	J	
1	Design Table for: 7 Hole Flatbar										
2		D1@Sketch1		D2@Sketch1	D1@Boss-Extrude1	D1@Sketch2	D3@LPattern1	D1@LPattern1	D1@Fillet1		
3	Default	3	0.25	0.09	0.19	0.5	7	0.01			
4	3HOLE	1	0.25	0.09	0.19	0.5	3	0.01			
5	5HOLE	2	0.25	0.09	0.19	0.5	5	0.01			
6	9HOLE	4	0.25	0.09	0.19	0.5	9	0.01			
7											
8											
9											
10											

### 13 Enter DESCRIPTION custom property.

- Double-click Cell I2.
- Enter **\$PRP@DESCRIPTION.**
- Click Cell I3.
- Enter **7Hole.**
- Click Cell I4.
- Enter **3Hole.**
- Click Cell I5.
- Enter **5Hole.**
- Click Cell I6.
- Enter **9Hole.**

	A	B	C	D	E	F	G	H	I	J	
1	Design Table for: 7 Hole Flatbar										
2		D1@Sketch1		D2@Sketch1	D1@Boss-Extrude1	D1@Sketch2	D3@LPattern1	D1@LPattern1	D1@Fillet1	\$PRP@DESCRIPTION	
3	Default	3	0.25	0.09	0.19	0.5	7	0.01	7HOLE		
4	3HOLE	1	0.25	0.09	0.19	0.5	3	0.01	3HOLE		
5	5HOLE	2	0.25	0.09	0.19	0.5	5	0.01	5HOLE		
6	9HOLE	4	0.25	0.09	0.19	0.5	9	0.01	9HOLE		
7											
8											
9											
10											





- Select **A (ANSI) Landscape** for Sheet Format/Size.
- Select **Third angle** for Type of projection.
- Click **OK**. Sheet2 is created. Sheet2 is displayed in the FeatureManager and in the Graphics window.

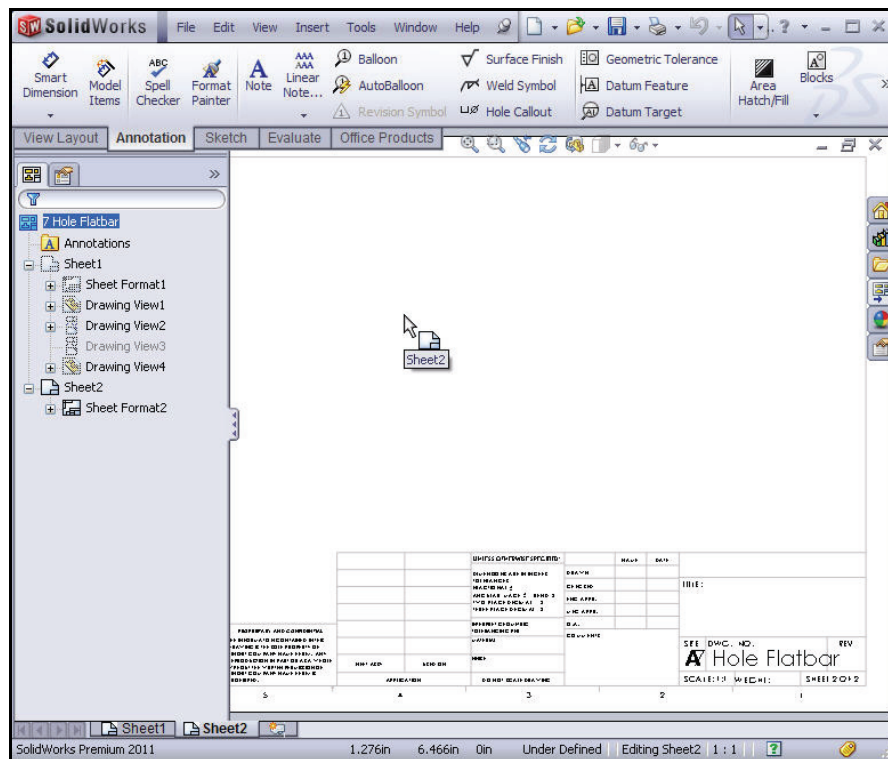
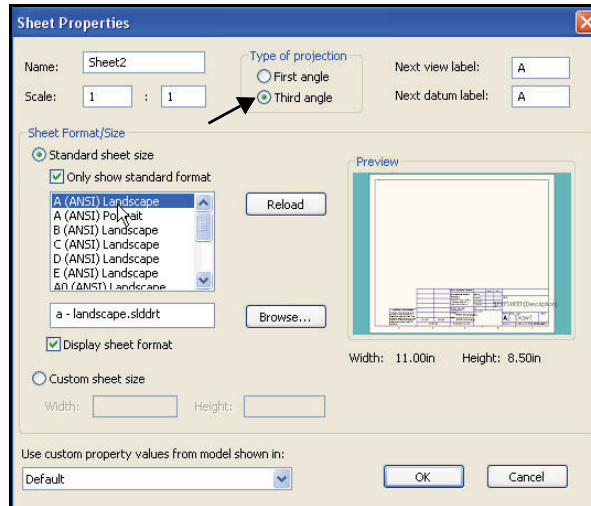

3 Return to Sheet1.

- Click the **Sheet1** tab in the lower left corner of the Graphics window. Sheet1 is displayed.

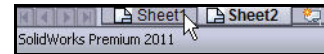

4 Copy the Front view of Sheet1.

- Click the **7 Hole Flatbar Front view** boundary. The Drawing View1 PropertyManager is displayed. The Drawing View1 view boundary is displayed in blue.

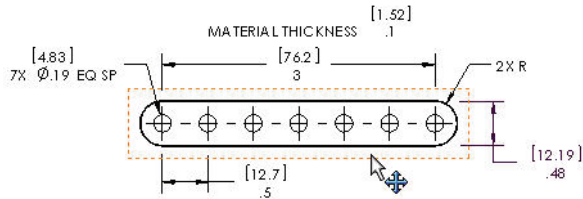

- Click **Edit, Copy** from the Menu bar menu.

5 Paste the Front view in Sheet2.

- Click the **Sheet2** tab.
- Click a **position** inside Sheet2.
- Click **Edit, Paste** from the Menu bar menu. The Front view in Sheet1 is displayed in the Sheet2 Graphics window. Drawing View5 is displayed in the 7 Hole Flatbar drawing FeatureManager.

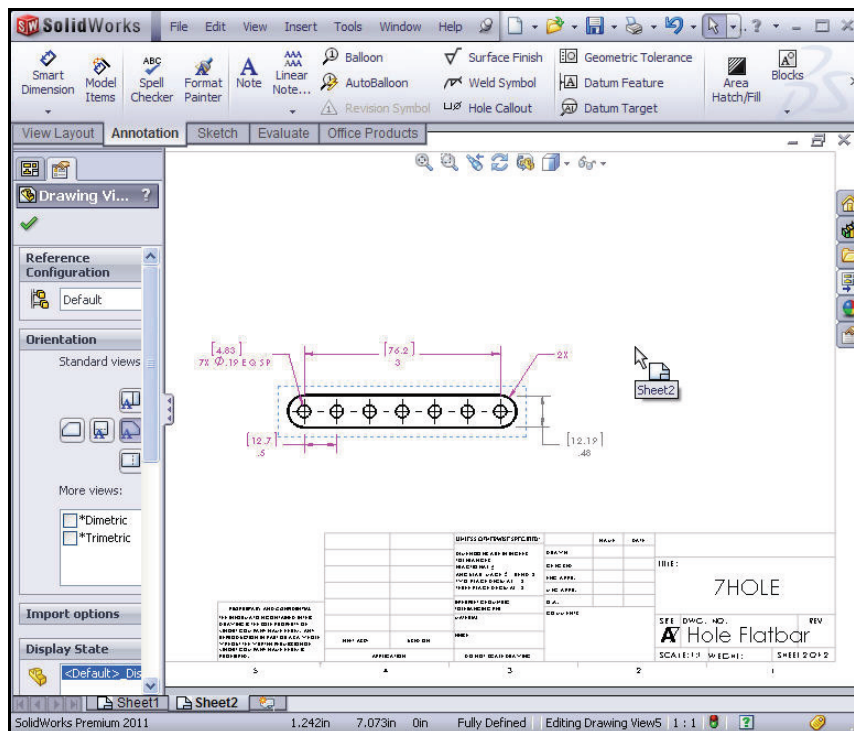

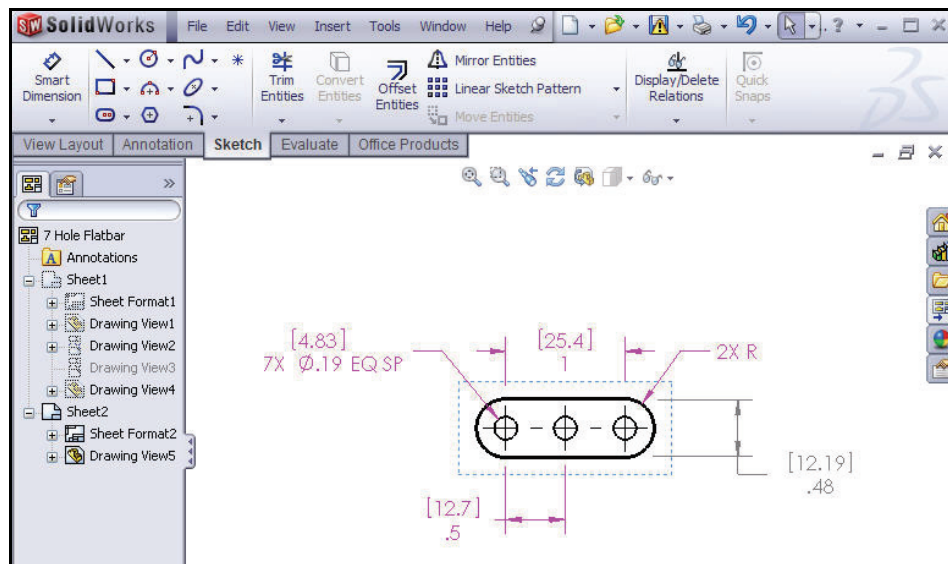
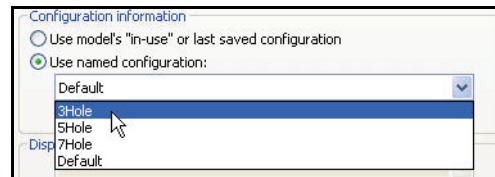
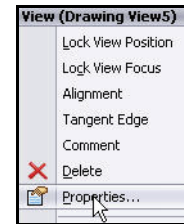

## 6 Display the 3Hole configuration.

- Right-click in the **Drawing View5** view boundary.
- Click **Properties**. The Drawing View Properties box is displayed.
- Select **3Hole** from the Use named configuration list.
- Click **OK**. The 3Hole Flatbar configuration is displayed.
- Move the **dimensions** off the model as illustrated.



## 7 Open the 7 Hole Flatbar part.

- Right-click in the **Drawing View5** view boundary.
- Click **Open Part**. The 7 Hole Flatbar part is displayed in the Graphics window.

- Click the **ConfigurationManager**  tab.
- Double-click the **3Hole** configuration.
- 8 Return to the part FeatureManager.**
- Click the **FeatureManager**  tab.
- 9 Return to the 7 Hole Flatbar drawing, Sheet2.**
- Click **Window, 7 Hole Flatbar - Sheet2** from the Menu bar toolbar.

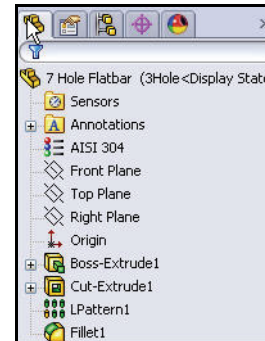
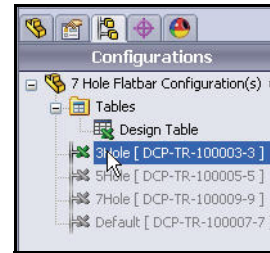

**10 Modify the 3Hole drawing.**

- Click the **7X** dimension text in Drawing View5. The dimension text is displayed in blue. The Dimension PropertyManager is displayed.

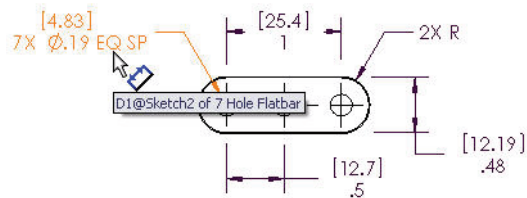

- Delete **7X** in the Dimension Text box.
- Enter **3X**.
- Click **OK**  from the Dimension PropertyManager.

**11 Modify the Title block of Sheet2.**

- Right-click in the **Graphics window**.
- Click **Edit Sheet Format**. The Title block lines turn blue. View the right side of the Title block.

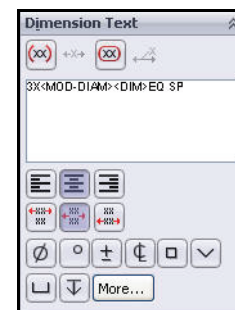



## Sharing Information and Viewing eDrawings Files

For many, 2D drawings still play an important role in communicating information to customers, vendors, and suppliers. Have you ever sent a CAD drawing file to someone only to have them complain, “I can't open this file”?

Have you had to communicate with someone who was using a different CAD system than you? Have you ever sent 2D drawings to someone only they didn't have a CAD system at all? It is also inefficient to plot the drawings, roll them up, and drop them in the mail.

### eDrawings™

eDrawings files are an email-enabled communications tool designed to dramatically improve sharing and interpreting 2D mechanical drawings.

eDrawings files are small enough to email, are self-viewing, and significantly easier to understand than 2D drawings.

### Viewing eDrawings

You can view eDrawings files in a very dynamic and interactive way. Unlike static 2D drawings, eDrawings files can be animated and viewed dynamically from all angles. The ability to interact with eDrawings files easily, in an interactive manner, makes it a very effective design collaboration tool.

### Advantages of eDrawings

- Recipients do not need to have the SolidWorks application to view the file.
- View parts, assemblies, and drawings outside of SolidWorks.
- Files are compact enough to email.
- Creating an eDrawings file is quick and simple.
- Select the eDrawings  tool from the eDrawings toolbar or click File, Publish to eDrawings to publish an eDrawings file from any SolidWorks file.
- You can create eDrawings files from other CAD systems.

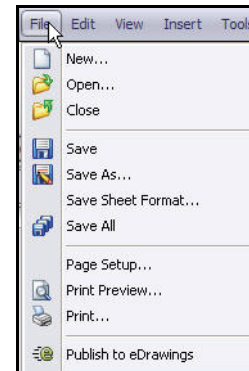

## Creating and Viewing an eDrawings File

- 1 **Create an eDrawings file.**
  - Click **File, Publish to eDrawings** from the Menu bar menu.
  - Click **Current Sheet**.
  - Click **OK**. The 7 Hole Flatbar Sheet2 eDrawings file is displayed.
- 2 **Play the eDrawing.**
  - Click **Play**.
  - Click **Stop**.
  - Click **Home**.

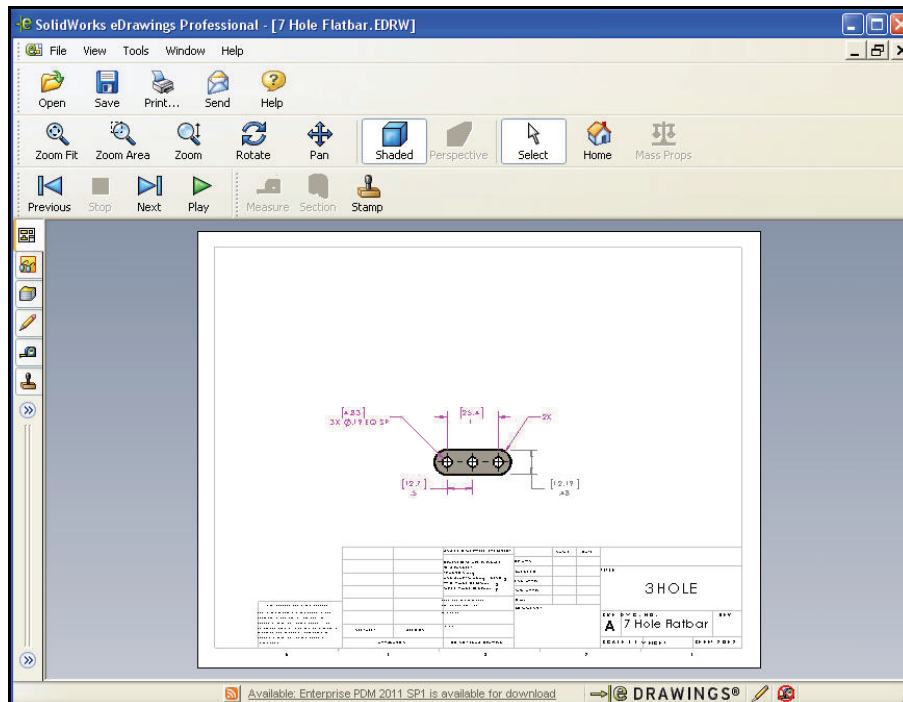
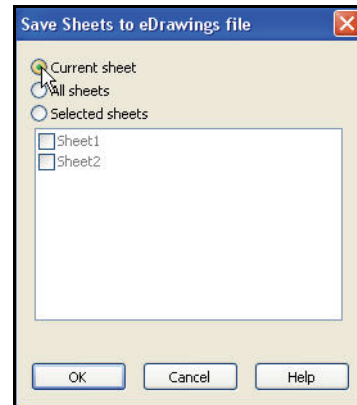

## Saving eDrawings Files

You can save eDrawings files in one of several formats. You can save eDrawings as:

eDrawings - Part, assembly, and drawing eDrawings files that can be viewed by systems that already have eDrawings.

HTML - eDrawings files that are viewed using browsers that support HTML.

Executable - Self-contained executable file that contains the eDrawings Viewer embedded in the file. These files have .exe as a file name suffix.

Zip - A compressed eDrawings file. These files have .zip as a file name suffix.

Image files - Utilized as pictures. These files have .bmp, .tiff, or .jpg as a file name suffix.

## Saving an eDrawings File



### 1 Save the eDrawings file.

- Click **File, Save** from the eDrawing Menu bar menu.
- Select the **SolidWorks-Trebuchet** folder. Accept the default name. The Save as type is: eDrawings Files (\*.edrw).
- Click **Save**.

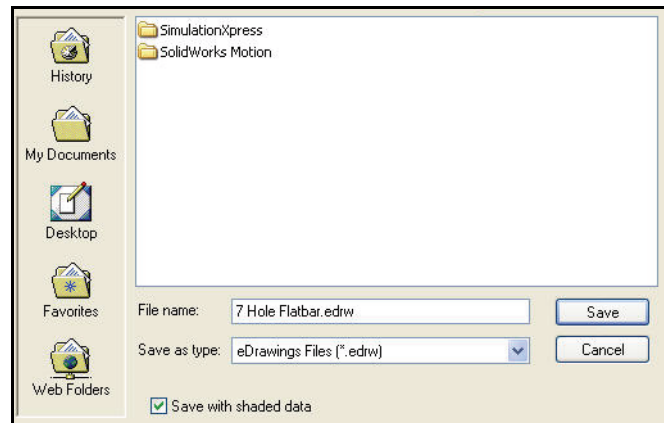
**Note:** The file can be viewed in a web browser.



## Returning to the 7 Hole Flatbar drawing

- 1 Close the eDrawings file.
  - Click  the eDrawings box. The 7 Hole Flatbar Sheet2 drawing is displayed.
- 2 Save the 7 Hole Flatbar drawing and close all active windows.
  - Click **Save** .
  - Click **Window, Close All** from the Menu bar toolbar.

## Creating an Assembly Drawing

- 1 Open the Counter Weight assembly.
  - Click **Open**  from the Menu bar toolbar.
  - Select the **SolidWorks-Trebuchet** folder.
  - Select **Assembly** for Files of type.
  - Double-click **Counter Weight**. The Counter Weight assembly is displayed in the Graphics window.



- 2 Create an assembly drawing.
  - Click **New**  from the Menu bar toolbar.
  - Double-click **Drawing** from the default Templates tab.

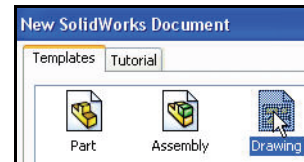

- Click **A (ANSI) Landscape**.
- Check **Standard sheet size**.
- Click **OK** from the Sheet Format/Size box.

The A (ANSI) Landscape paper is displayed in the new Graphics window. The sheet border defines the drawing size, 11in. x 8.5in.[279.4mm x 215.9mm].

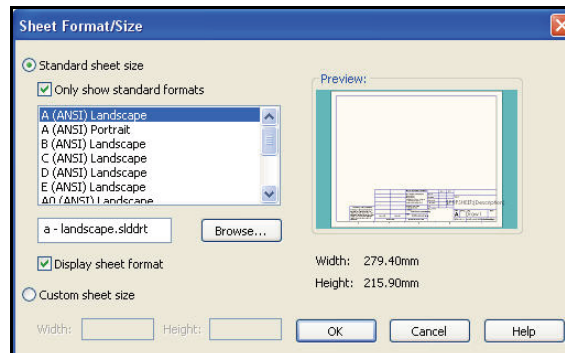

**3 Close the Model View PropertyManager.**

- Click the **Cancel**  tool from the Model View PropertyManager. The Draw FeatureManager is displayed. Sheet1 is displayed in the Graphics window.

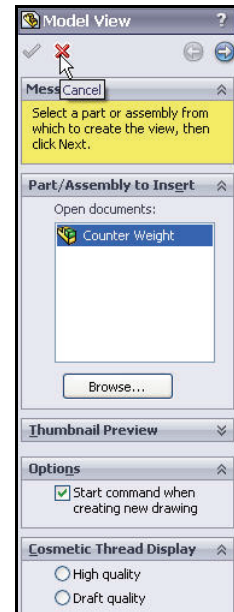

**4 Set Third Angle Projection.**

- **Right-click** in the Graphics window.
- Click **Properties**.
- Check the **Third angle** box for Type of projection.
- Click **OK** from the Sheet Properties dialog box.

**Note:** Third Angle Projection is used in the Lesson.

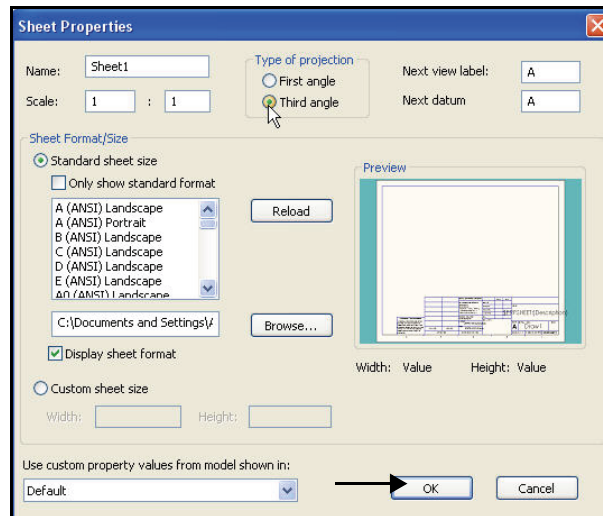

### 5 Set Drafting Standard.

- Click **Options**  **Document Properties** tab from the Menu bar toolbar. The Document Properties - Drafting Standard dialog box is displayed.
- Select **ANSI** for Overall drafting standard.

### 6 Set unit system and length.

- Click **Units**.
- Click **IPS** (inch, pound, second) for Unit system.
- Select **.123** for Length unit decimal place.
- Select **None** for Angle decimal place.
- Select **millimeters** for Dual Dimension Length.

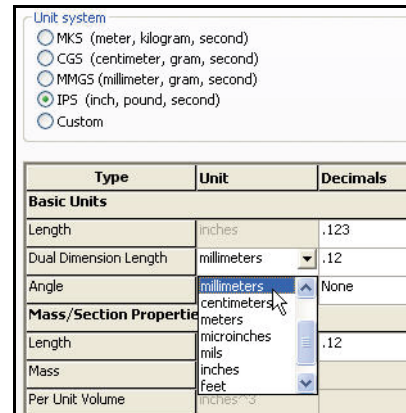

### 7 Set dual unit display.

- Click **Dimensions** from the Document Properties dialog box.
- Check the **Dual dimensions display** box.

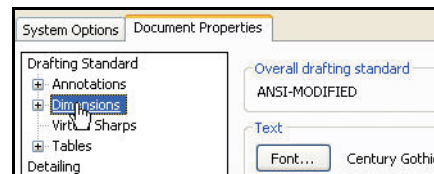

### 8 Set System options.

- Click **OK** from the Document Properties-Dimensions dialog box.

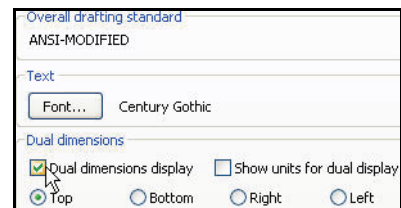

### 9 Insert the Counter Weight assembly.

- Click the **View Layout** tab from the CommandManager.
- Click the **Model View**  tool from the View Layout toolbar. The Model View PropertyManager is displayed.



## Creating a Trebuchet Drawing

## SolidWorks

- Click **Counter Weight** in the Open documents box.
- Click **Next** . Drawing view names are based on the part view orientation.

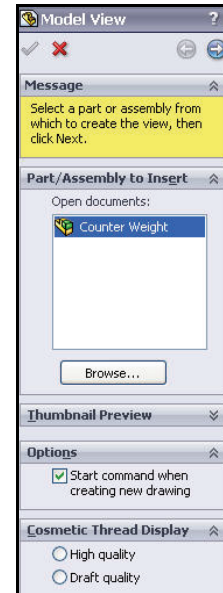

### 10 Insert a Shaded With Edges Isometric view.

- If needed click **\*Isometric** in the Orientation box.
- Click **Shaded With Edges** from the Display Style box.

**Note:** Single View is activate by default.

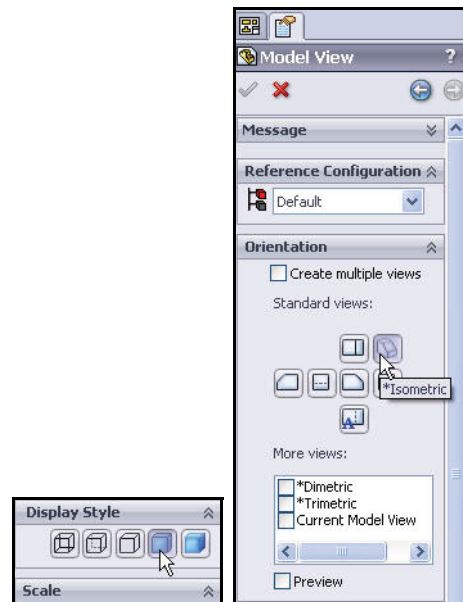

- Click a **position** for the Isometric view in the upper right corner of Sheet1.
- 11 Deactivate the Origins.**
- If needed, click **View**, un-check **Origins** from the Menu bar menu.

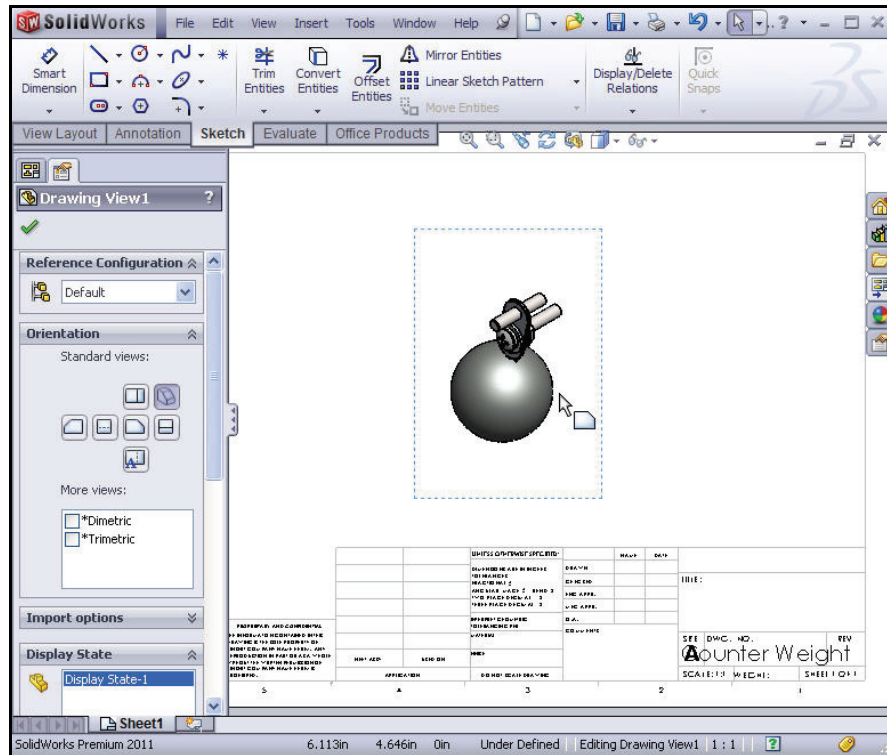

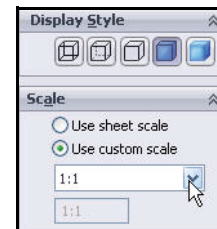

**12 Modify the model scale.**

- Check the **Use custom scale** box from the Scale option.
- Select **1:1**.
- Click **OK**  from the Drawing View1 PropertyManager.



**13 Modify the Title box.**

- Right-click in the **Graphics window**.
- Click **Edit Sheet Format**. The Title block lines turn blue.
- Click the **Zoom to Area**  tool.
- **Zoom in** on the Title block.
- Click the **Zoom to Area**  tool to deactivate.

**14 Modify the DWG. NO. font size.**

- Double-click **Counter Weight** in the Title block.
- Click the **drop-down** arrows to set the Text Font from the formatting toolbar.
- Select **14** for size.
- Click **OK**  from the Note PropertyManager.

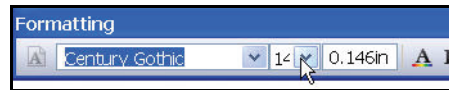

**15 Activate the Edit Sheet mode.**

- Right-click in the **Graphics window**.
- Click **Edit Sheet**.
- Press the **f** key to fit the model to Sheet1.

**16 Save the Counter Weight drawing.**

- Click **Save** . Accept the defaults.
- Click **Save All**.
- Click **Save** from the Save As box.

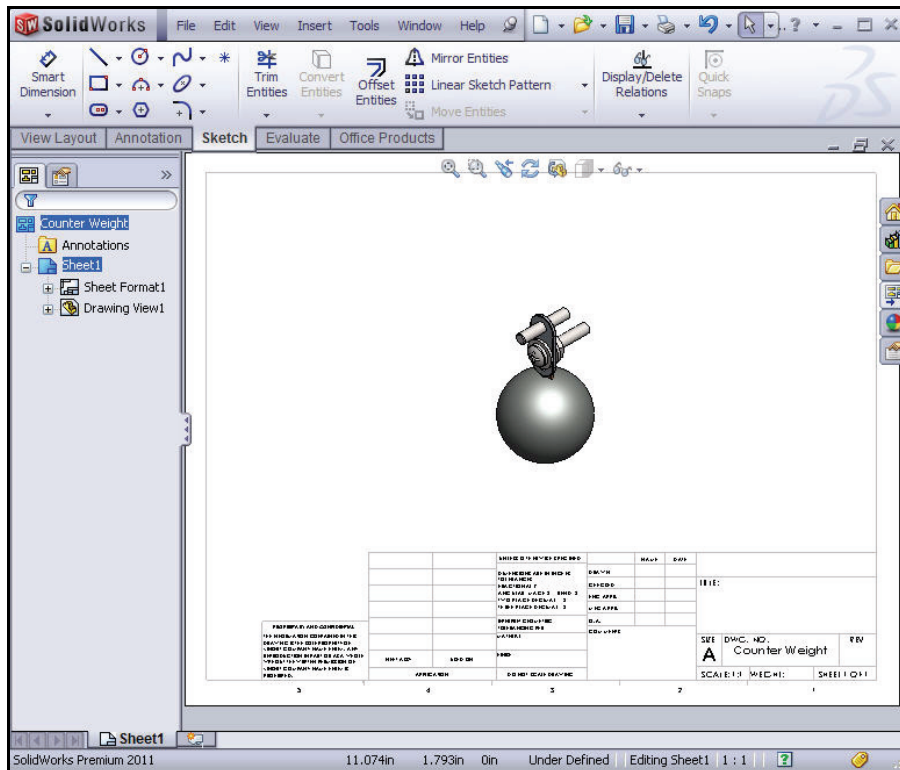

## Exploded Views

For manufacturing purposes, it is often useful to separate the components of an assembly to visually analyze their relationships. Exploding the view of an assembly allows you to look at it with the components separated. While an assembly is exploded, you cannot add mates to the assembly.

An exploded view consists of one or more explode steps. An exploded view is stored with the assembly configuration with which it is created.

Each configuration can have one exploded view.

You will create an exploded view of the Counter Weight assembly. You will then display the exploded view in the Counter Weight assembly drawing.

**Note:** You can animate the exploded view to represent how an assembly would be assembled on the manufacturing floor. With SolidWorks Animator, you can record the animation to an AVI file.

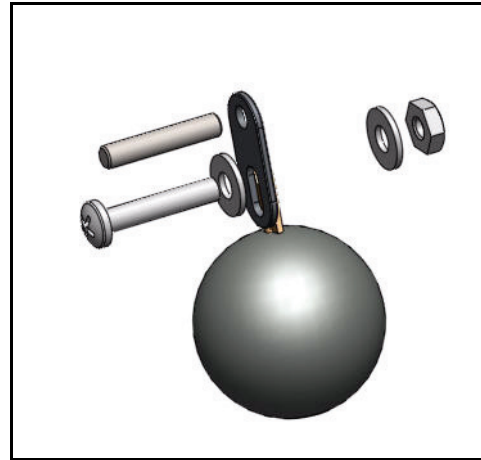

## Inserting an Exploded View

### 1 Open the Counter Weight assembly.

- Right-click inside the **Isometric view**.
- Click **Open Assembly**. The Counter Weight assembly is displayed in the FeatureManager.

### 2 Insert an Exploded view.

- Click the **Assembly** tab from the CommandManager.
- Click the **Exploded View**  tool from the Assembly toolbar. The Explode PropertyManager is displayed.

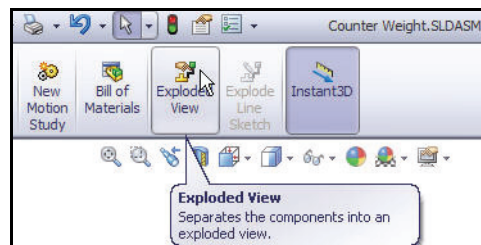
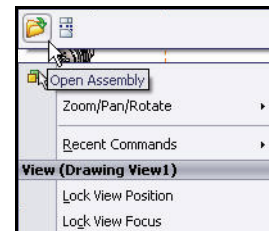

## Creating a Trebuchet Drawing

SolidWorks

### 3 Create Explode Step1.

- Click the **cylindrical face** of the Axle in the Graphics window as illustrated.

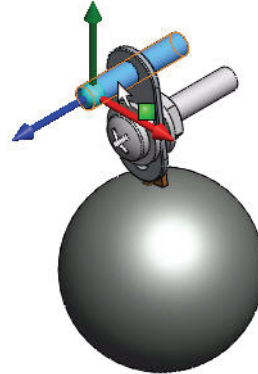

- Drag the **blue/orange reference triad** to the front. Explode Step1 is created. View the on-screen ruler.
- Click **Done** from the Settings box.

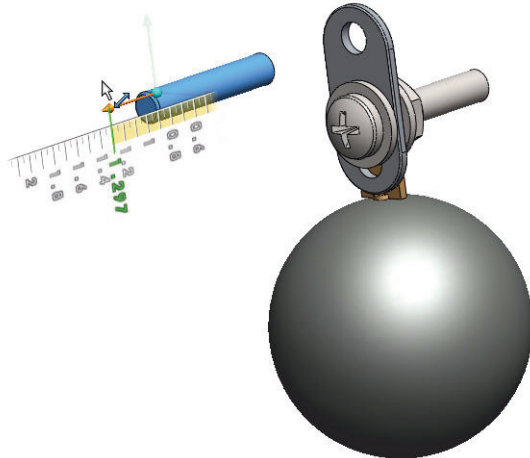

### 4 Create Explode Step2.

- Click the **BaseNut** on the bolt as illustrated.

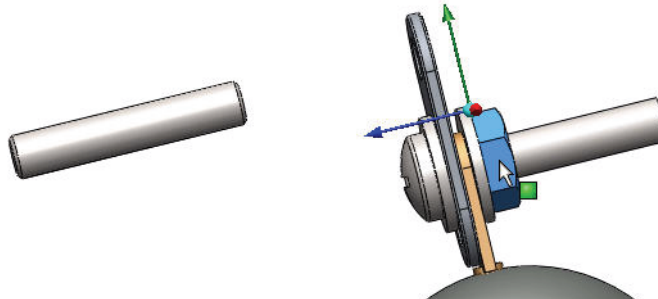

## SolidWorks

## Creating a Trebuchet Drawing

- Drag the **blue/orange reference triad** to the back. Explode Step2 is created.
- Click **Done**.

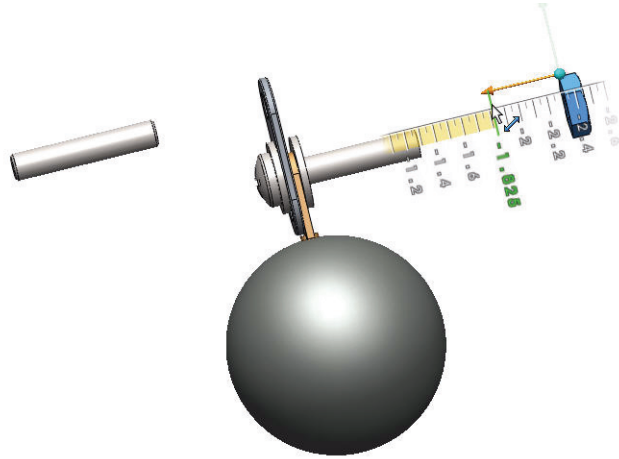

### 5 Create Explode Step3.

- Click the **Washer** on the back side of the bolt as illustrated.

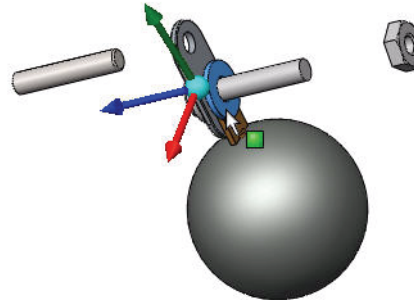

- Drag the **blue/orange reference triad** to the back. Explode Step3 is created.
- Click **Done**.
- Click **Isometric**  view.

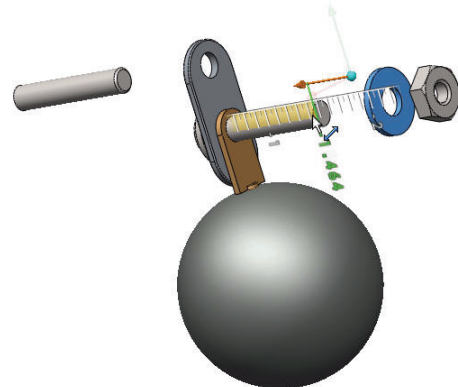

**6 Create Explode Step4.**

- Click the **Bolt head** of the Counter Weight as illustrated.

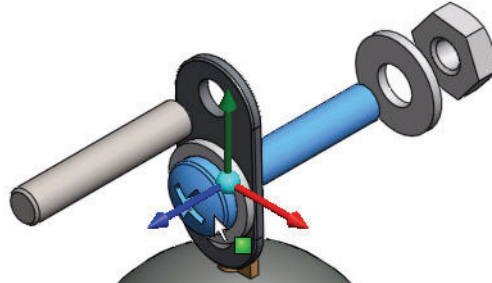

- Drag the **blue/orange reference triad** to the front. Explode Step4 is created.
- Click **Done**.



**7 Create Explode Step5.**

- Click the **Washer** on the front side of the Counter Weight as illustrated.

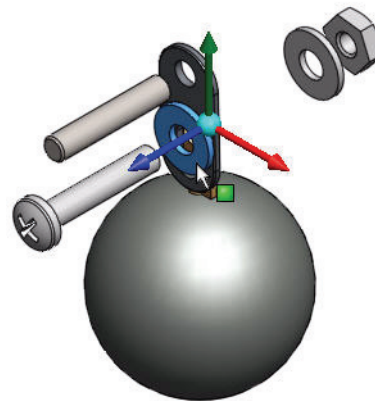

## SolidWorks

## Creating a Trebuchet Drawing

- Drag the **blue/orange reference triad** to the front. Explode Step5 is created.
- Click **Done**.

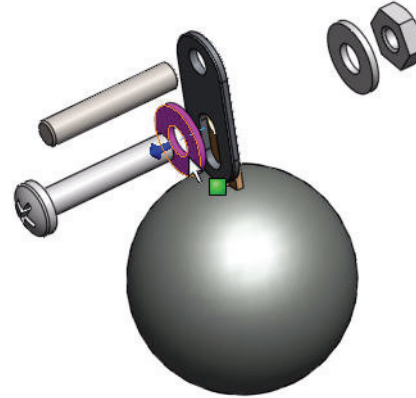

### 8 View the Exploded Steps.

- **Expand** each Explode Step in the Explode Steps box.

### 9 View the Results.

- Click **OK**  from the Explode PropertyManager.

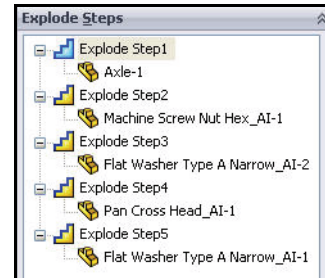

### 10 View the ConfigurationManager.

- Click the **ConfigurationManager**  tab.
- **Expand** the Default folder.
- **Expand** ExplView1. View the Exploded Steps.

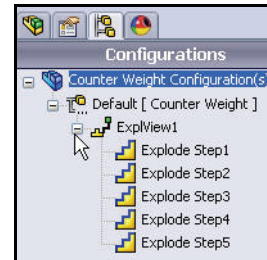

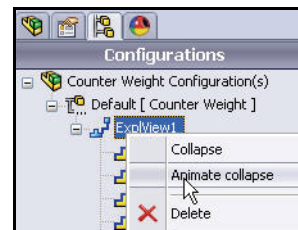

### 11 Animate Collapse.

- Right-click **ExplView1**.
- Click **Animate collapse** in the ConfigurationManager. View the animation.

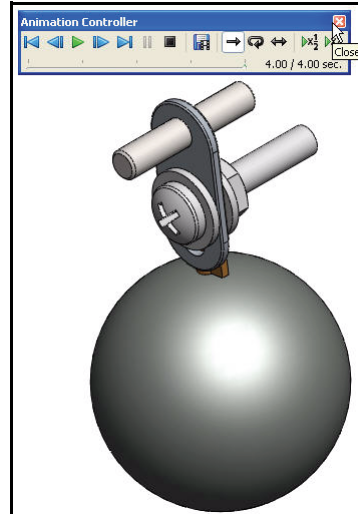

- Close  the Animation Controller.
- 12 **Return to the Counter Weight FeatureManager.**
  - Click the **FeatureManager**  tab. The Counter Weight FeatureManager is displayed.



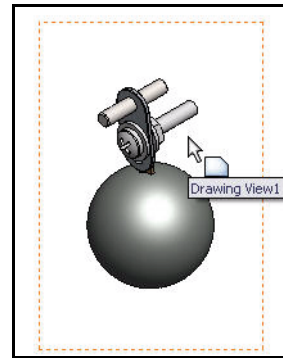

- 13 **Save the model.**
  - Click **Isometric**  view.
  - Click **Save** .
- 14 **Return to the Counter Weight drawing.**
  - Click **Window, Counter Weight - Sheet1** from the Menu bar toolbar.
- 15 **Set the Exploded state in the drawing.**
  - Click **inside** the Isometric view boundary.

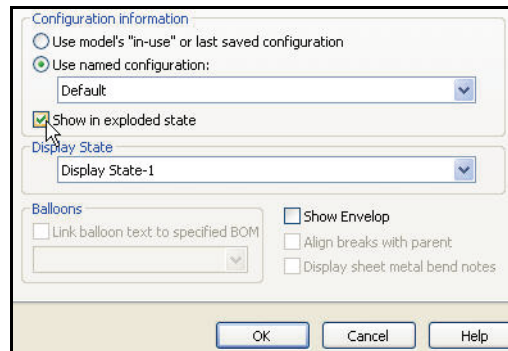

- Right-click **Properties.**
- Check the **Show in exploded state** box.
- Click **OK.**



- Click **OK**  from the Drawing View1 PropertyManager. The Exploded view of the Counter Weight is displayed in the drawing.
  - Click the **Rebuild**  tool from the Menu bar toolbar.
- 16 Save the Counter Weight drawing.**
- Click **Save** .

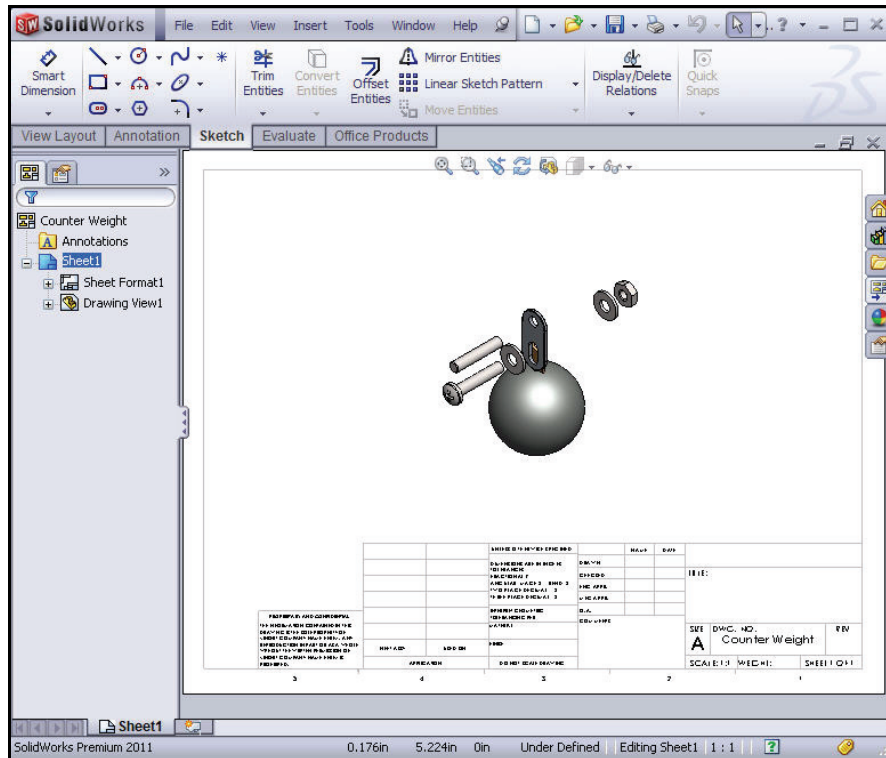

**17 Collapse the Exploded state in the drawing.**

- Click **inside** the Isometric view boundary.
- Right-click **Properties**.
- Un-check the **Show in exploded state** box.
- Click **OK**.
- Click **OK**  from the Drawing View1 PropertyManager.

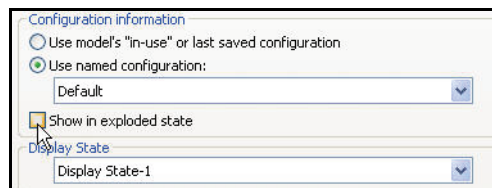

- Click **Rebuild** .
- 18 **Save the Counter Weight drawing.**
- Click **Save** .

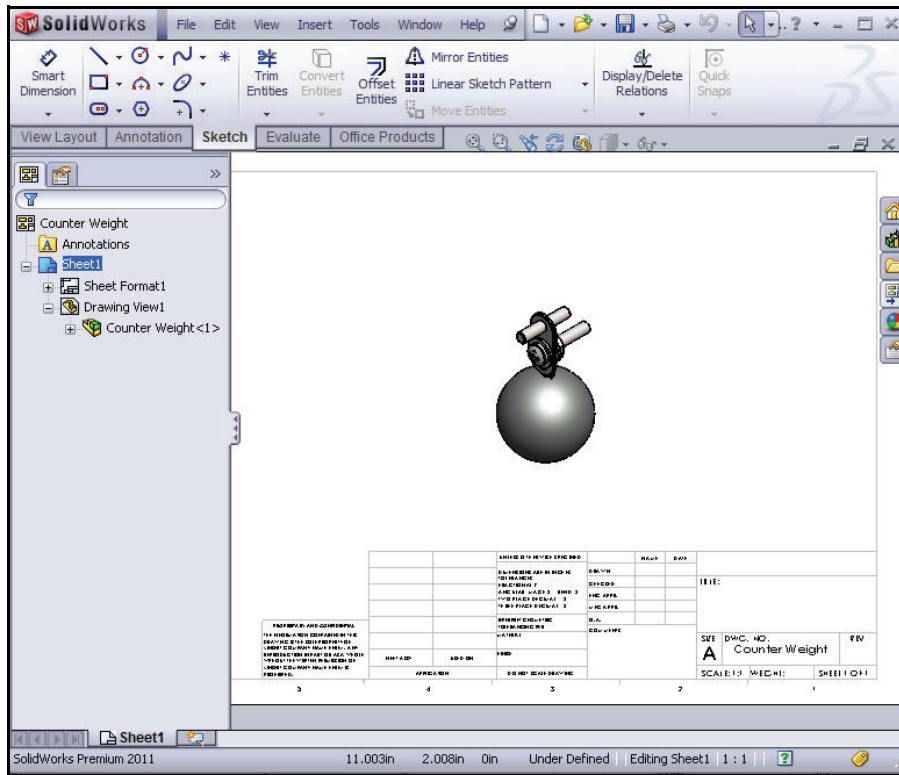

## Inserting a Bill of Materials

A bill of materials (BOM) describes a product in terms of its assemblies, sub-assemblies, and basic parts. The BOM is hierarchical and is usually shown as an indented list. Sub-assemblies are indented under the top-level assembly; individual parts are indented under sub-assemblies.

A SolidWorks bill of materials is created in an assembly drawing, and it automatically manages the data that is linked between the bill of materials and an assembly file and its parts.

### 1 Insert a Bill of Materials.

- Click the **Annotation** tab from the CommandManager.
- Click the **Bill of Materials**  tool from the Consolidated Tables toolbar.

### 2 Select the Isometric view.

- Click inside the **Isometric view** of the Counter Weight. The Bill of Materials PropertyManager is displayed.

### 3 Select the BOM template.

- Select **bom-standard** from the Table Template box.
- Check **Parts only** from the BOM Type box.
- Click **OK**  from the Bill of Materials PropertyManager. The Bill of Materials is attached to the mouse pointer.

### 4 Position the BOM.

- Click a **position** in the top left corner of the drawing. View the results.

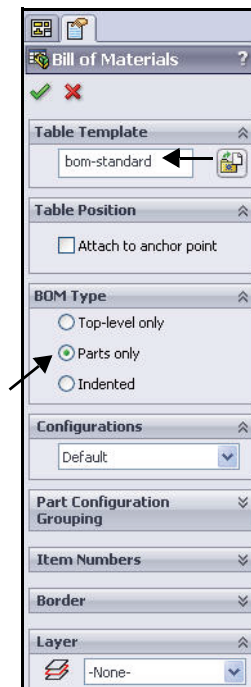
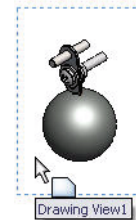
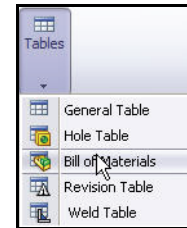



## 2 Set the Axle Part number.

- Click the Axle **ConfigurationManager**  tab.
- Right-click **Default**.
- Click **Properties**. The Configuration Properties PropertyManager is displayed.

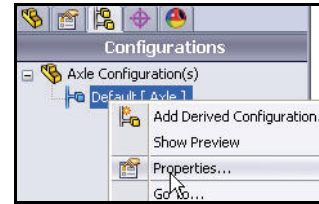

## 3 Set User Specified Name.

- Select **User Specified Name** in the drop-down arrow menu from the Bill of Materials Options.
- Enter **DCP-10000101** for the Part Number displayed when used in a bill of materials.
- Click **OK**  from the Configuration Properties PropertyManager. Default [DCP-10000101] is displayed in the ConfigurationManager.

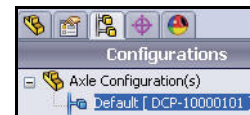
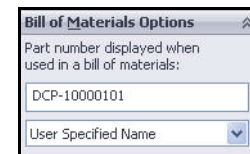
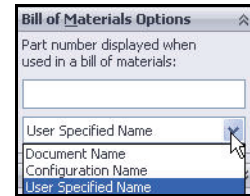

## 4 Return to the part FeatureManager.

- Click the **FeatureManager**  tab. The Axle FeatureManager is displayed.

## 5 Save the Axle.

- Click **Save** .

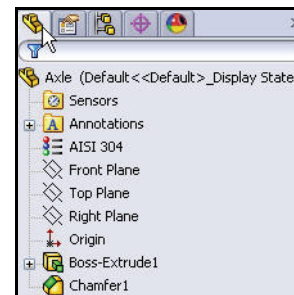

6 Return to the Counter Weight drawing.

- Click **Window, Counter Weight - Sheet1** from the Main menu. View the updated Bill of Materials.

ITEM NO.	PART NUMBER	DESCRIPTION	QTY.
1	DCP-10000101		1
2	CR-2-1-001	Flat	1
3	Preferred Narrow FW 0.19		2
4	CR-PHMS 0.19-24x1x1-N		1
5	Weight-Hook		1
6	MSHXXNUT 0.190-24-S-N		1



UNITS	DESCRIPTION	DATE
DRAMA		
CMCCTB		
PLG APP		
WIG APP		
D.A		
COMMENTS		

PROPRIETARY AND CONFIDENTIAL  
THIS DRAWING CONTAINS THE  
DESIGN AND INTELLECTUAL PROPERTY OF  
DUPRE COMPANY PART #001 - ANY  
REPRODUCTION IN PART OR AS A WHOLE  
WITHOUT THE WRITTEN PERMISSION OF  
DUPRE COMPANY PART #001 IS  
PROHIBITED.

REV A DWG. NO. Counter Weight REV

SCALE: 1:1 WEIGHT: SHEET 1 OF 1

Adding a Bill of Materials Description

Add a description to the Axle, PART NUMBER: DCP-1000010. The rest of the descriptions in the Counter Weight Bill of Materials will be left as an exercise.

**Note:** Add meaningful descriptions to all items.

1 Add a description to the Bill of Materials.

Open the Axle part.

- Click **Open**  from the Menu bar toolbar.
- Double-click **Axle** from the SolidWorks-Trebuchet folder. The Axle is displayed in the Graphics window.

## 2 Set the Axle Part description.

- Click the Axle **ConfigurationManager**  tab.
- Right-click **Default**.
- Click **Properties**. The Configuration Properties PropertyManager is displayed.
- Click the **Custom Properties** box. The Summary Information box is displayed.

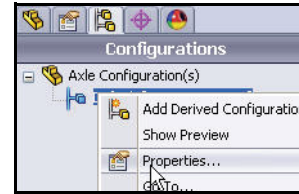

## 3 Add a part description.

- Click inside the **Property Name** box as illustrated.
- Select **Description**.
- Click inside the **Value / Text Expression** box.
- Enter **AXLE**.
- Click the **Evaluated Value** box. The information is displayed.
- Click **OK** from the Summary Information box. The Configuration Properties PropertyManager is displayed.

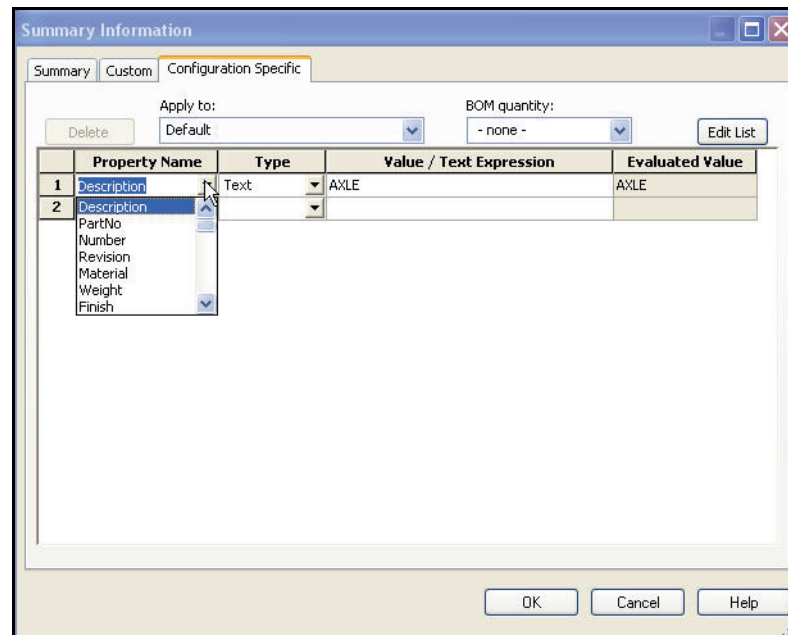
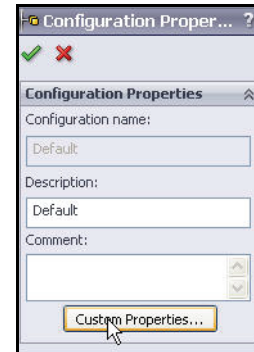



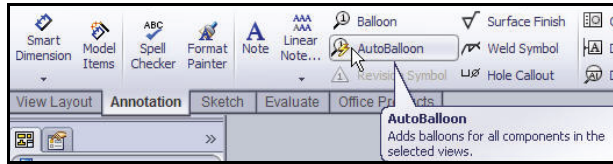

### Inserting Balloons

Balloons label the parts in the assembly and relate them to the item numbers in the bill of materials.



#### 1 Insert balloons into the drawing.

- Click **inside** the Isometric view boundary.
- Click the **AutoBalloon**  tool from the Annotation toolbar. The Auto Balloon PropertyManager is displayed. Accept the defaults.
- Click **OK**  from the Auto Balloon PropertyManager. View the inserted drawing balloons.
- Click and drag the **balloons** off the model to improve visibility.

#### 2 Save the Counter Weight drawing.

- Click **Save** .

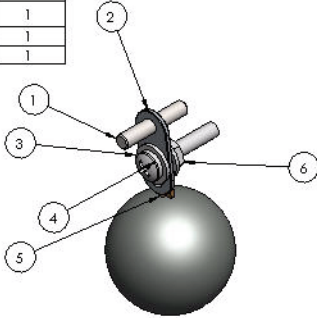

ITEM NO.	PART NUMBER	DESCRIPTION	QTY.
1	DCP-10000101	AXLE	1
2	CR-2-1-001	Flat	1
3	Preferred Narrow FW 0.19		2
4	CR-PHMS 0.19-24x1x1-N		1
5	Weight-Hook		1
6	MSSHXLUT 0.190-24-S-N		1



<p style="font-size: small;">PROPERTY AND CONFIDENTIAL INFORMATION CONTAINED IN THIS DRAWING IS THE SOLE PROPERTY OF SPECTRUM PARTS, INC. ANY REPRODUCTION IN WHOLE OR IN PART WITHOUT THE WRITTEN PERMISSION OF SPECTRUM PARTS, INC. IS PROHIBITED.</p>	<p style="font-size: small;">UNLESS OTHERWISE SPECIFIED:</p> <p style="font-size: x-small;">DIMENSIONS ARE IN INCHES TOLERANCES: FIN SURFACE ± .0001 IN HIDDEN SURFACE ± .0005 IN HOLE SURFACE ± .0005 IN HOLE POSITION ± .001 IN HOLE DRILLING ± .001 IN</p> <p style="font-size: x-small;">UNLESS OTHERWISE SPECIFIED: TOLERANCES: MATERIAL</p> <p style="font-size: x-small;">MFG APPR: _____ DATE: _____ DESIGNER: _____ CHECKED: _____ APPROVED: _____</p>	<p style="font-size: small;">SEE DWG. NO. _____ REV _____</p> <p style="font-size: small;">SCALE: 1:1 WEIGHT: _____ SHEET 1 OF 1</p>
--	---	--

## Creating an Trebuchet Assembly Drawing

### 1 Open the Trebuchet assembly.

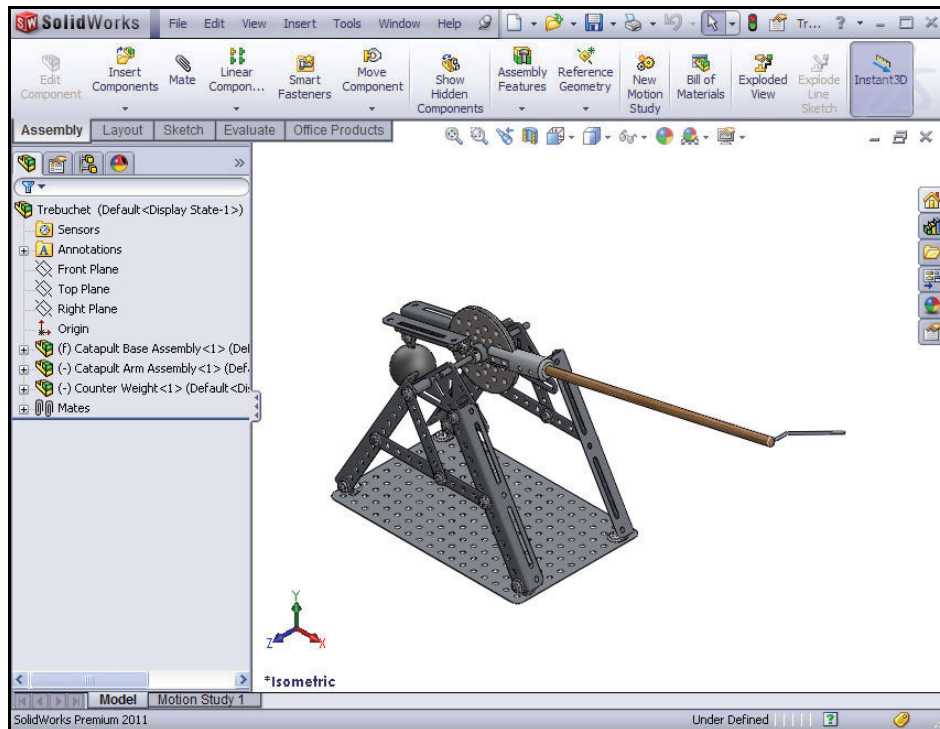

- Click **Open**  from the Menu bar toolbar.
- Select the **SolidWorks-Trebuchet** folder.
- Select **Assembly** for Files of type.
- Double-click **Trebuchet**.
- Click **Isometric**  view. The Trebuchet is displayed in the Graphics window.

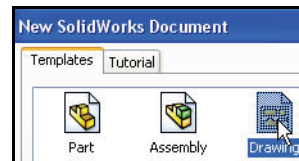

### 2 Create an Trebuchet Assembly drawing.

- Click **New**  from the Menu bar toolbar.
- Double-click **Drawing** from the default Templates tab.
- Click **A (ANSI) Landscape**.
- Check **Standard sheet size**.



- Click **OK** from the Sheet Format/Size box.
  - Click **Cancel**  from the PropertyManager. Draw# is displayed in the new Graphics window.
- 3 Set Drafting Standard.**
- Click **Options** , **Document Properties** tab from the Menu bar toolbar. The Document Properties - Drafting Standard dialog box is displayed.
  - Select **ANSI** for Overall drafting standard.
- 4 Set unit system and length.**
- Click **Units**.
  - Click **IPS** (inch, pound, second) for Unit system.
  - Select **.123** for Length unit decimal place.
  - Select **None** for Angle decimal place.
  - Select **millimeters** for Dual Dimension Length.
- 5 Set dual unit display.**
- Click **Dimensions** from the Document Properties dialog box.
  - Check the **Dual dimensions display** box.
- 6 Set System options.**
- Click **OK** from the Document Properties-Dimensions dialog box.

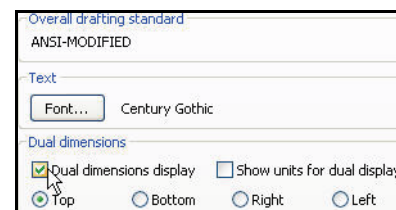
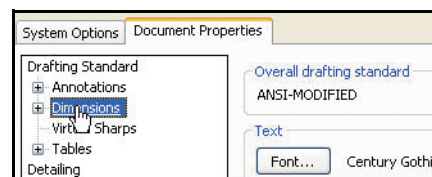
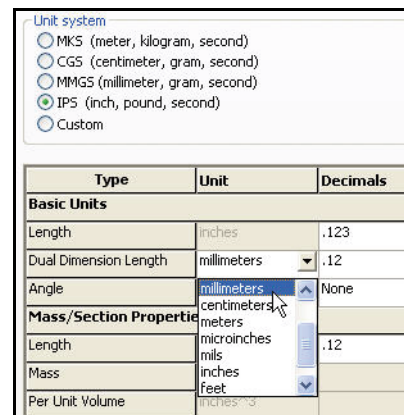
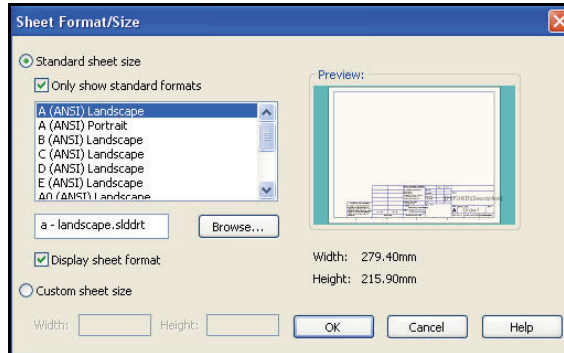

**7 Set Third Angle Projection.**

- **Right-click** in the Graphics window.
- Click **Properties**.
- Check the **Third angle** box for Type of projection.
- Click **OK** from the Sheet Properties dialog box.

**Note:** Third Angle Projection is used in the Lesson.

**8 Insert the Trebuchet assembly using the View Palette.**

- Click the **View Palette**  tab from the Task Pane.
- Select **Trebuchet** from the drop-down View Palette menu.

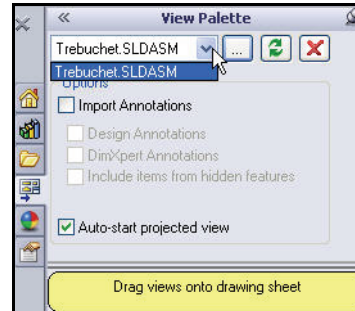

- Click and drag the **\*Isometric** view into Sheet1. The Isometric view of the Trebuchet is displayed on Sheet1.

**9 Deactivate the Origins.**

- If needed, click **View**, un-check **Origins** from the Menu bar menu.

**10 Display a Shaded With Edges view.**

- Click **Shaded With Edges** from the Display Style dialog box.

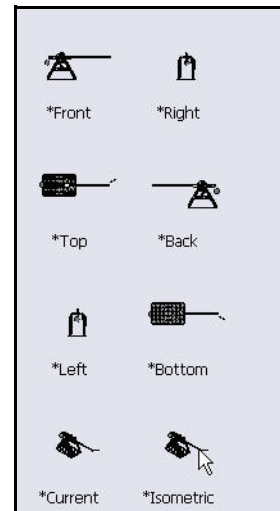

**11 Select model scale.**

- Check the **Use customer scale** box.
- Select **User Defined** from the Scale box.
- Enter **1:3**.
- Click **OK**  from the Drawing View1 PropertyManager. Drawing View1 is displayed in the FeatureManager.

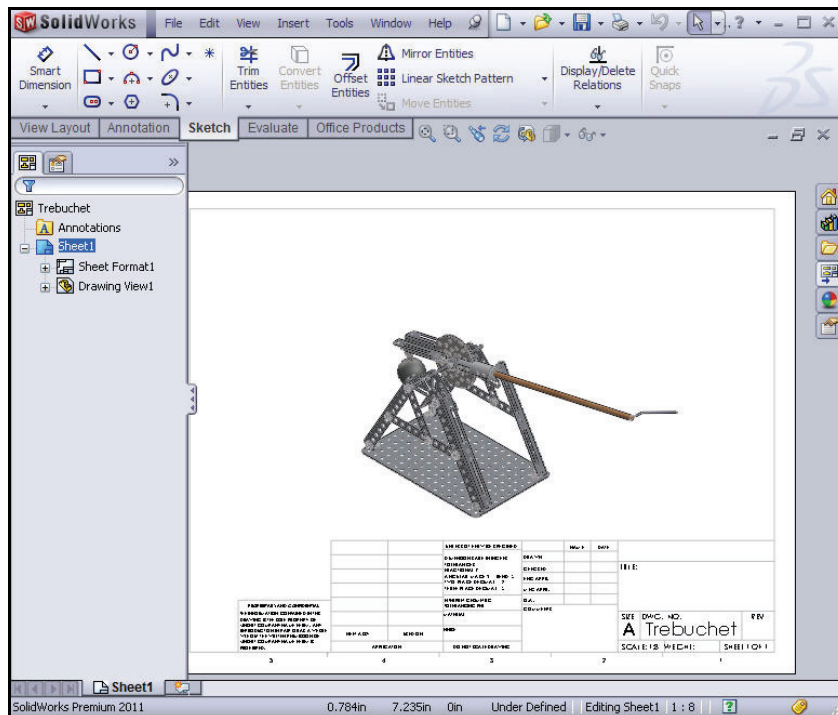
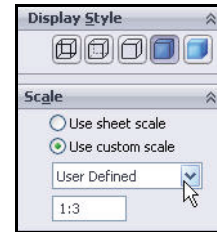
**12 Save the Trebuchet drawing.**

- Click **Save** .
- Click **Save All**. Accept the defaults.
- Click **Save** from the Save As box.

### Inserting a Bill of Materials

- 1 **Insert a Bill of Materials.**
  - Click the **Annotation** tab from the CommandManager.
  - Click the **Bill of Materials**  tool from the Consolidated Tables toolbar.
- 2 **Select the Isometric view.**
  - Click inside the **Isometric view** of the Trebuchet. The Bill of Materials PropertyManager is displayed.
- 3 **Select the BOM template.**

In this drawing, you will create a BOM using only the Top level components.

  - Select **bom-standard** from the Table Template box.
  - Check **Top level only** from the BOM Type box.
  - Click **OK**  from the Bill of Materials PropertyManager. The Bill of Materials is attached to the mouse pointer.
- 4 **Position the BOM.**
  - Click a **position** in the top left corner of the drawing. View the inserted BOM.

The BOM displays the ITEM NO., PART NUMBER, DESCRIPTION, and QTY. of the Trebuchet assembly. The Bill of Materials for the Trebuchet assembly is incomplete. As an exercise, complete the Bill of Materials for the Trebuchet drawing. Add Part numbers and description for each Item.

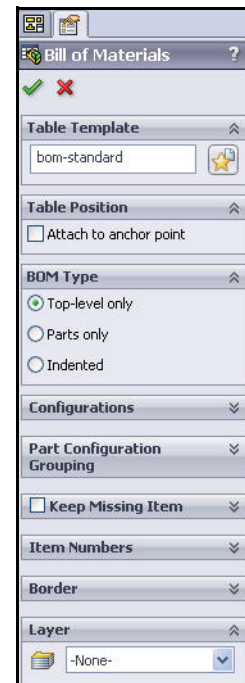
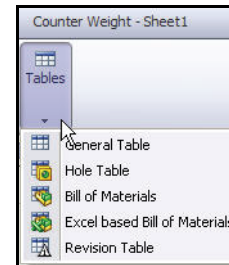

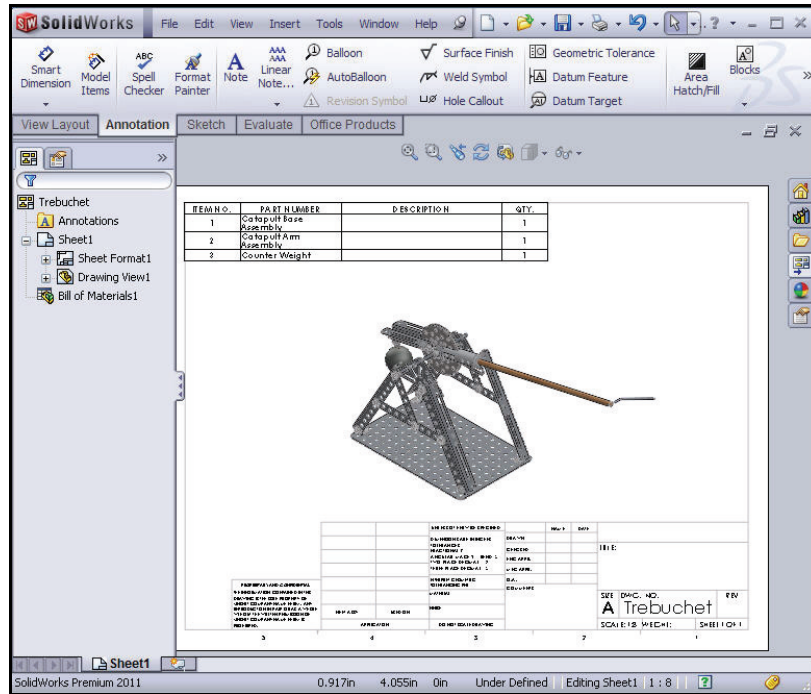

**Note:** To access the components in the Bill of Materials, expand Sheet1, expand Drawing View1, expand Trebuchet from the Trebuchet drawing FeatureManager.

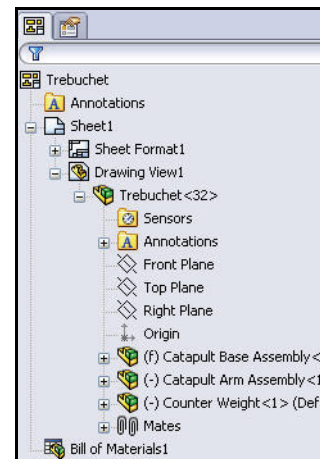

## Inserting the String and Ball Assembly

### 1 Open the String and Ball assembly.

- Click **Open**  from the Menu bar toolbar.
- Double-click the **String and Ball** assembly from the SolidWorks-Trebuchet folder. The String and Ball assembly FeatureManager is displayed. View the String and Ball assembly in the Graphic window.

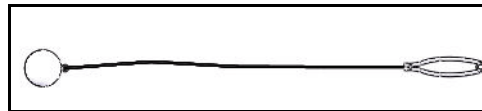
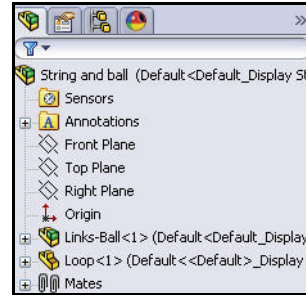

### 2 If needed, open the Trebuchet Assembly.

- Click **Open**  from the Menu bar toolbar.
- Double-click **Trebuchet** from the SolidWorks-Trebuchet folder. The Trebuchet assembly is displayed in the Graphics window.

### 3 Insert the String and Ball assembly.

- Click the **Insert Components**  tool from the Assembly toolbar. The Model View PropertyManager is displayed.
- Click **String and Ball** in the Open documents box.
- Click a position to the **right** of the Trebuchet as illustrated.

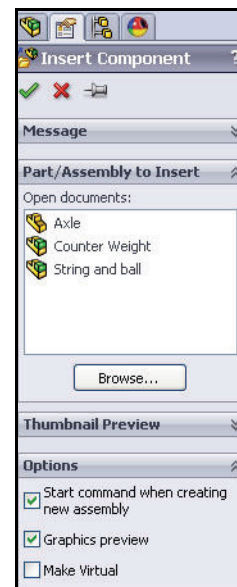

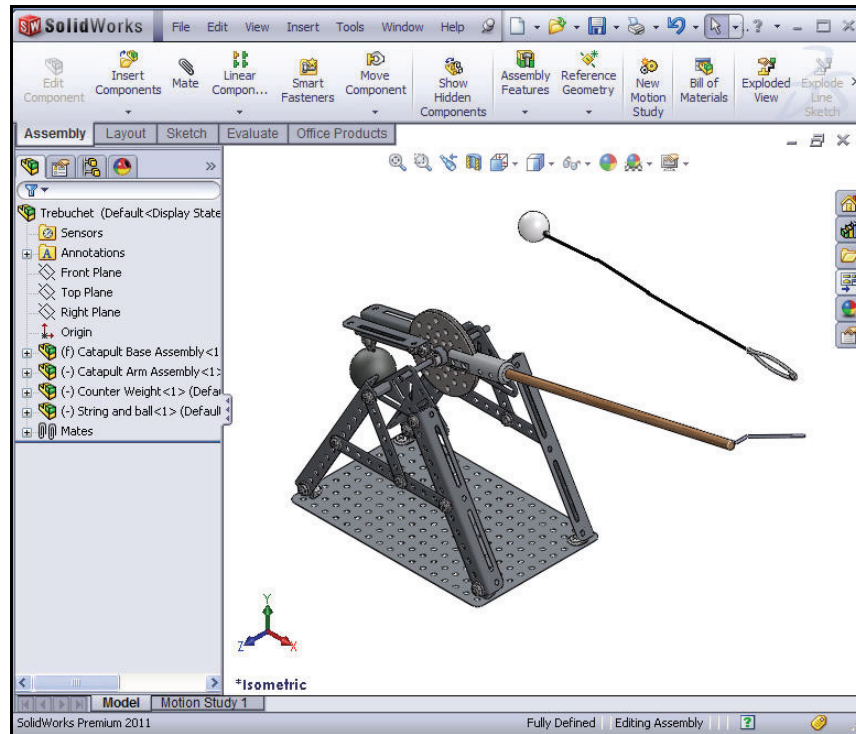



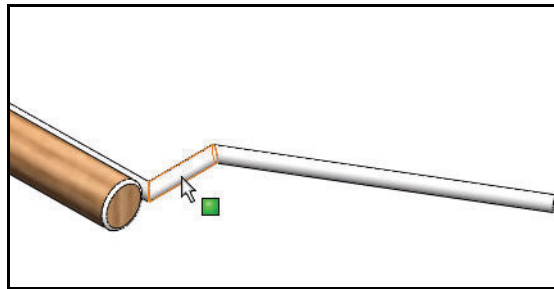

#### 4 Insert a Concentric Mate.

Insert a Concentric mate between the paperclip cylindrical face on the Catapult arm and the inside cylindrical face of the loop on the String and Ball assembly.

- Click the **Cylindrical face** of the paperclip as illustrated.
- Click the **Mate**  tool from the Assembly toolbar. Face<1>@Catapult Arm is displayed in the Mate Selection box.



- Click the **Zoom to Area**  tool.
- **Zoom in** on the loop on the String and Ball assembly.
- Click the **Zoom to Area**  tool to deactivate.
- Click the **cylindrical inside face** of the loop as illustrated. Face<2>@String and Ball is displayed in the Mate Selection box. The Mate Pop-up toolbar is displayed. Concentric is the default mate type.
- Click the **Add/Finish Mate**  tool from the Mate Pop-up toolbar.

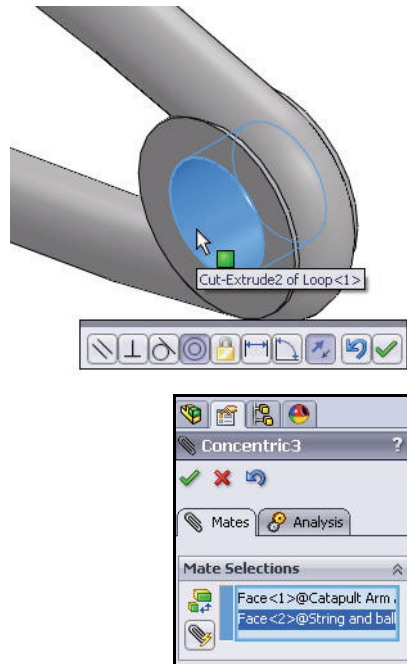

**5 Align the Catapult arm to the String and Ball assembly.**

- Click and **drag** the Catapult arm to the String and Ball assembly as illustrated.

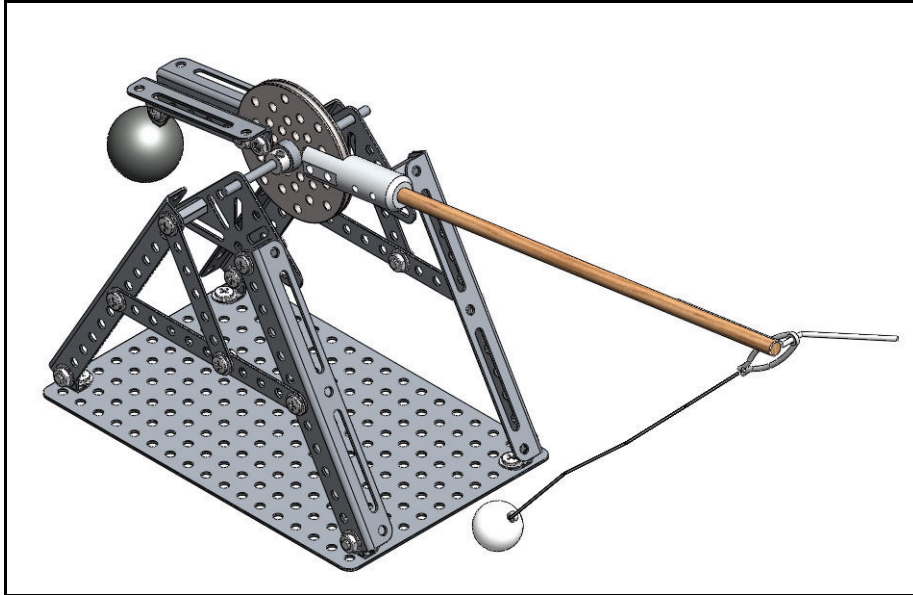

**6 Insert a Tangent Mate.**

Insert a Tangent mate between the wood ball face on the String and Ball assembly and the flat plate face of the Catapult Base assembly.

- If required, Right-click **Clear Selections** in the Mate Selections box.
- Using the middle mouse button, **click** and **rotate** the assembly to view the face of the ball.
- Click the **ball face** on the catapult arm as illustrated.

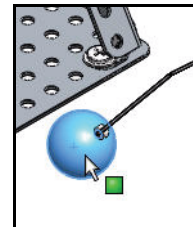

Face<3>@String and Ball is displayed in the Mate Selection box.

- Click the **flat plate face of the Catapult Base** assembly as illustrated. Face<4>@Catapult Base is displayed in the Mate Selection box. The Mate Pop-up toolbar is displayed.

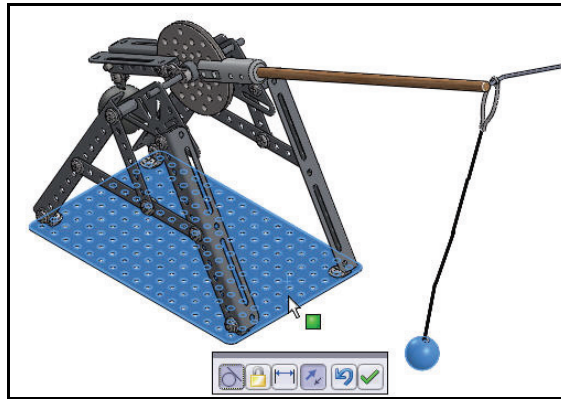

- Click the **Add/Finish Mate**  tool from the Mate Pop-up toolbar.

- Click **OK**  from the Mate PropertyManager.

**7 Fit the model to the Graphics window.**

- Press the **f** key.

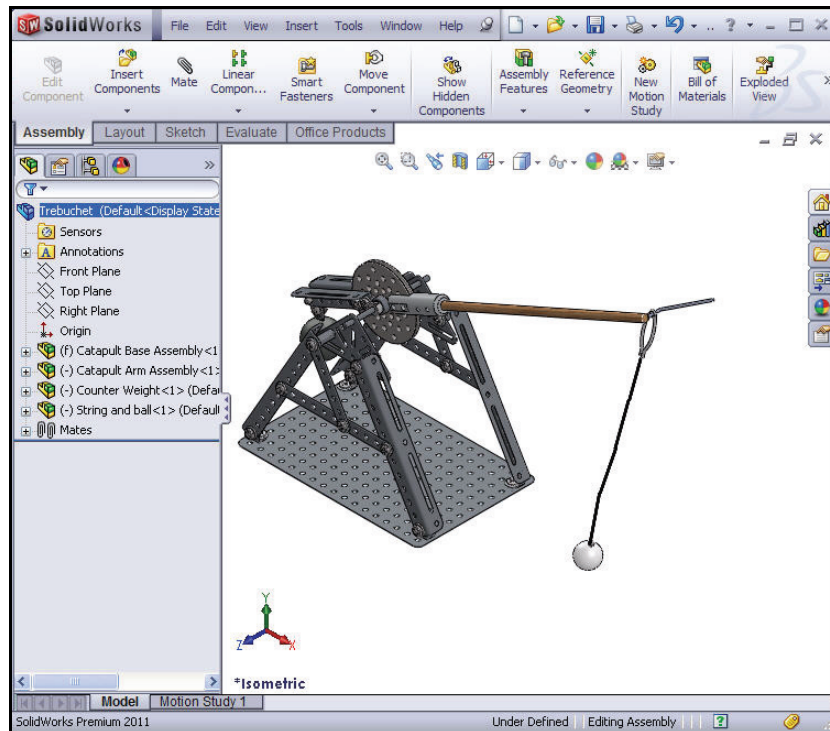

**8 Save the model.**

- Click **Isometric**  view.
- Click **Save** .

**9 Return to the Trebuchet drawing.**

- Click **Window, Trebuchet - Sheet1** from the Menu bar toolbar. The Trebuchet drawing is displayed. View the updated drawing and Bill of Materials.

**10 Close all models.**

- Click **Window, Close All** from the Menu bar toolbar. You have successfully completed this lesson.

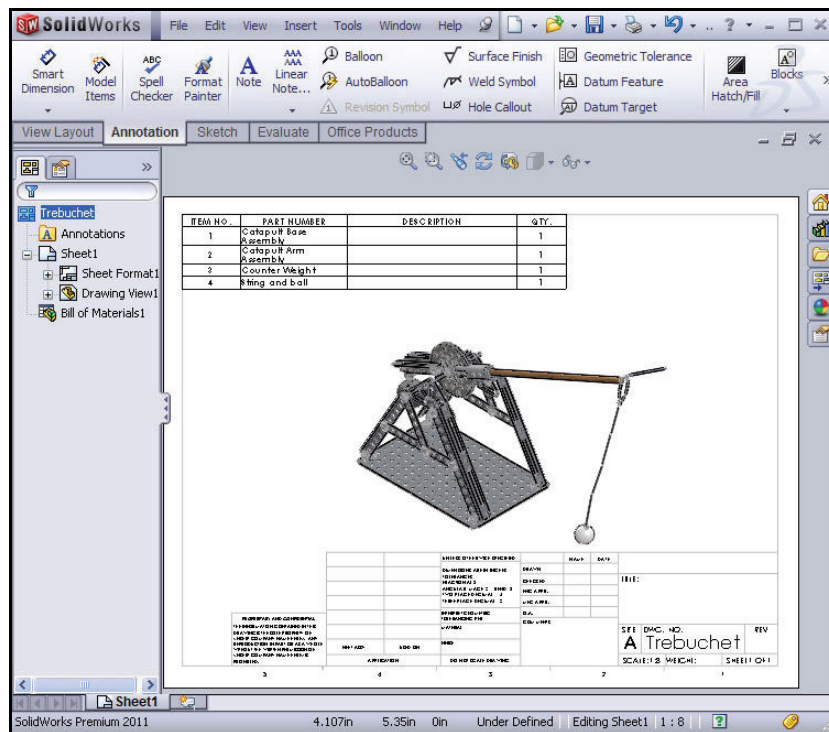

In Lesson 5 you created the following drawings:

- 7 Hole Flatbar.
- Counter Weight.
- Trebuchet

In the 7 Hole Flatbar drawing you addressed:

- Setting document properties.
- Inserting a Front, Top, Right, and Isometric views.
- Setting display style.
- Setting Title block size.
- Inserting view dimensions.
- Adding a view dimension.
- Adding and linking a Part Parametric Note.
- Hiding the Right view.
- Adding a Sheet to the drawing.
- Applying a Design Table Configuration.
- Creating an eDrawing.

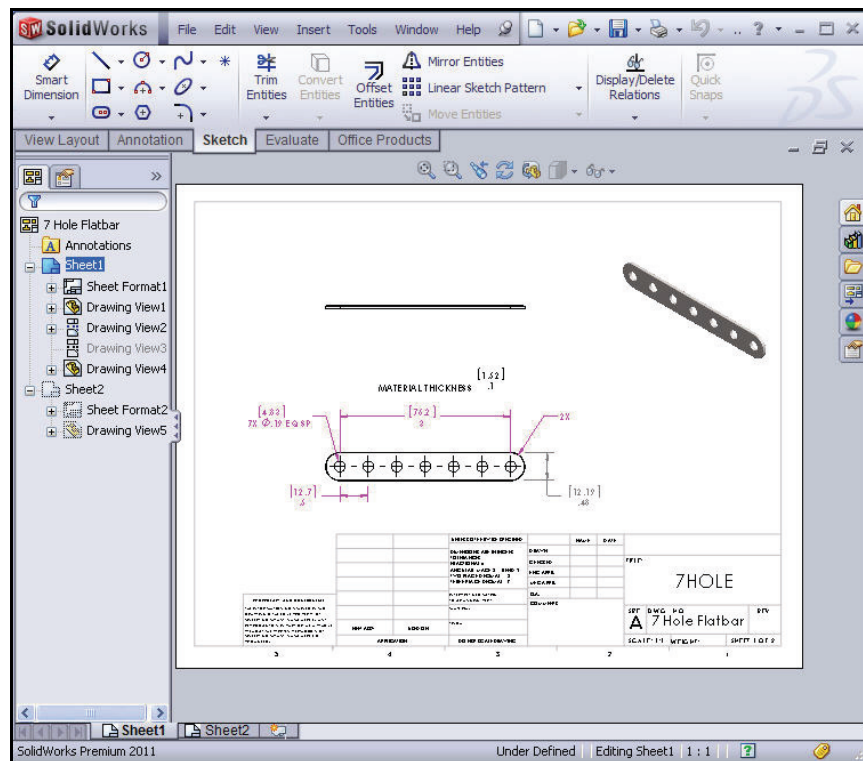

In the Counter Weight drawing you addressed:

- Setting document properties.
- Inserting an Isometric view.
- Setting display style.
- Setting Title block size.
- Inserting a Bill of Materials at a Part level.
- Inserting Balloons.
- Inserting Part Numbers and Description to the Bill of Materials.
- Creating an Exploded view.

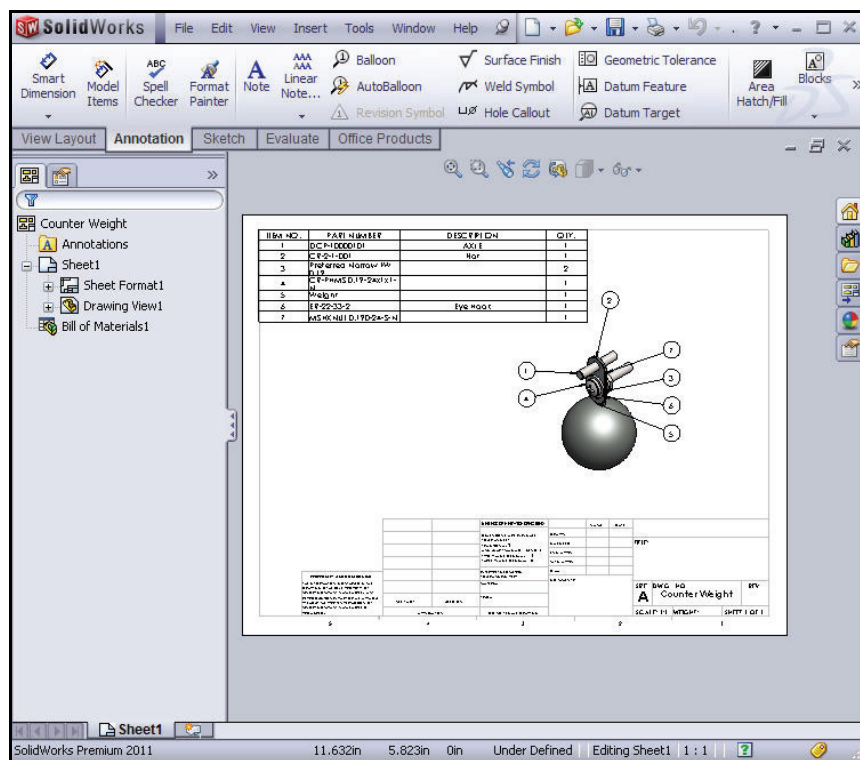

In the Trebuchet drawing you addressed:

- Setting document properties.
- Inserting an Isometric view.
- Setting Display style
- Changing scale.
- Changing Title block font.
- Inserting a Bill of Materials at a Top level.
- Inserting a new component.
- Inserting Standard Mates
- Updating an Assembly.

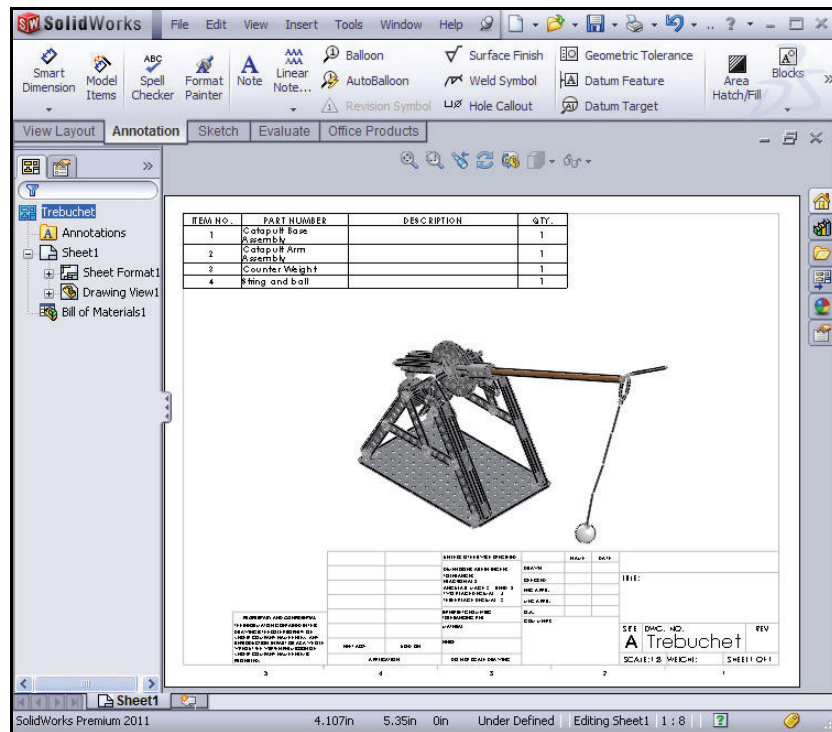

## Glossary

<b>Term</b>	<b>Definition</b>
<b>animate</b>	View a model or eDrawing in a dynamic manner. Animation simulates motion or displays different views.
<b>assembly</b>	An assembly is a document in which parts, features, and other assemblies (sub-assemblies) are mated together. The parts and sub-assemblies exist in documents separate from the assembly. For example, in an assembly, a piston can be mated to other parts, such as a connecting rod or cylinder. This new assembly can then be used as a sub-assembly in an assembly of an engine. The extension for a SolidWorks assembly file name is *.sldasm.
<b>axis</b>	An axis is a straight line that can be used to create model geometry, features, or patterns. An axis can be made in a number of different ways, including using the intersection of two planes.
<b>boss/base</b>	A base is the first solid feature of a part, created by a boss. A boss is a feature that creates the base of a part, or adds material to a part, by extruding, revolving, sweeping, or lofting a sketch, or by thickening a surface.
<b>Click-click</b>	As you sketch, if you click and then release the pointer, you are in click-click mode. Move the pointer and click again to define the next point in the sketch sequence.
<b>Click-drag</b>	As you sketch, if you click and drag the pointer, you are in click-drag mode. When you release the pointer, the sketch entity is complete.
<b>closed profile</b>	A closed profile (or closed contour) is a sketch or sketch entity with no exposed endpoints; for example, a circle.
<b>collapse</b>	Collapse is the opposite of explode. The collapse action returns an exploded assembly's parts to their normal positions.

<b>Term</b>	<b>Definition</b>
<b>collimate</b>	To make (as light rays) parallel
<b>component</b>	A component is any part or sub-assembly within an assembly.
<b>Configuration Manager</b>	The ConfigurationManager on the left side of the SolidWorks window is a means to create, select, and view the configurations of parts and assemblies.
<b>degrees of freedom</b>	Geometry that is not defined by dimensions or relations is free to move. In 2D sketches, there are three degrees of freedom: movement along the X and Y axes, and rotation about the Z axis (the axis normal to the sketch plane). In 3D sketches and in assemblies, there are six degrees of freedom: movement along the X, Y, and Z axes, and rotation about the X, Y, and Z axes.
<b>document</b>	A SolidWorks document is a file containing a part, assembly, or drawing.
<b>drawing</b>	A drawing is a 2D representation of a 3D part or assembly. The extension for a SolidWorks drawing file name is *.slddrw.
<b>drawing sheet</b>	A drawing sheet is a page in a drawing document.
<b>eDrawing</b>	Compact representation of a part, assembly, or drawing. eDrawings are compact enough to email and can be created for a number of CAD file types including SolidWorks.
<b>face</b>	A face is a selectable area (planar or otherwise) of a model or surface with boundaries that help define the shape of the model or surface. For example, a rectangular solid has six faces.
<b>feature</b>	A feature is an individual shape that, combined with other features, makes up a part or assembly. Some features — such as bosses and cuts — originate as sketches. Other features, such as shells and fillets, modify a feature's geometry. However, not all features have associated geometry. Features are always listed in the FeatureManager design tree.

<b>Term</b>	<b>Definition</b>
<b>FeatureManager design tree</b>	The FeatureManager design tree on the left side of the SolidWorks window provides an outline view of the active part, assembly, or drawing.
<b>graphics area</b>	The graphics area is the area in the SolidWorks window where the part, assembly, or drawing appears.
<b>line</b>	A line is a straight sketch entity with two endpoints. A line can be created by projecting an external entity such as an edge, plane, axis, or sketch curve into the sketch.
<b>mate</b>	A mate is a geometric relationship, such as coincident, perpendicular, tangent, and so on, between parts in an assembly.
<b>mategroup</b>	A mategroup is a collection of mates that are solved together. The order in which the mates appear within the mategroup does not matter.
<b>model</b>	A model is the 3D solid geometry in a part or assembly document. If a part or assembly document contains multiple configurations, each configuration is a separate model.
<b>named view</b>	A named view is a specific view of a part or assembly (isometric, top, and so on), or a user-defined name for a specific view. Named views from the view orientation list can be inserted into drawings.
<b>newton</b>	The SI(m-kg-s) unit of force. A force of one newton will accelerate a mass of one kilogram at the rate of one meter per second per second. In traditional English terms, one newton is about 0.225 pounds of force (lbf). The newton is named for Isaac Newton (1642-1727). He was the first person to understand clearly the relationship between force (F), mass (m), and acceleration (a), expressed by the formula $F = ma$ .
<b>open profile</b>	An open profile (or open contour) is a sketch or sketch entity with endpoints exposed. For example, a U-shaped profile is open.
<b>over defined</b>	A sketch is over defined when dimensions or relations are either in conflict or redundant.

<b>Term</b>	<b>Definition</b>
<b>part</b>	A part is a single 3D object made up of features. A part can become a component in an assembly, and it can be represented in 2D in a drawing. Examples of parts are bolt, pin, plate, and so on. The extension for a SolidWorks part file name is .sldprt.
<b>planar</b>	An entity is planar if it can lie on one plane. For example, a circle is planar, but a helix is not.
<b>plane</b>	Planes are flat construction geometry. Planes can be used for a 2D sketch, section view of a model, a neutral plane in a draft feature, and others.
<b>point</b>	A point is a singular location in a sketch, or a projection into a sketch at a single location of an external entity (origin, vertex, axis, or point in an external sketch).
<b>profile</b>	A profile is a sketch entity used to create a feature (such as a loft) or a drawing view (such as a detail view). A profile can be open (such as a U shape or open spline) or closed (such as a circle or closed spline).
<b>Property Manager</b>	The PropertyManager is on the left side of the SolidWorks window for dynamic editing of sketch entities and most features.
<b>rebuild</b>	The rebuild tool updates (or regenerates) the document with any changes made since the last time the model was rebuilt. Rebuild is typically used after changing a model dimension.
<b>relation</b>	A relation is a geometric constraint between sketch entities or between a sketch entity and a plane, axis, edge, or vertex. Relations can be added automatically or manually.
<b>revolve</b>	Revolve is a feature tool that creates a base or boss, a revolved cut, or revolved surface by revolving one or more sketched profiles around a centerline.
<b>section</b>	A section is another term for profile in sweeps.
<b>section view</b>	A section view (or section cut) is: (1) a part or assembly view cut by a plane, or (2) a drawing view created by cutting another drawing view with a section line.

<b>Term</b>	<b>Definition</b>
<b>sheet format</b>	A sheet format typically includes page size and orientation, standard text, borders, title blocks, and so on. Sheet formats can be customized and saved for future use. Each sheet of a drawing document can have a different format.
<b>shell</b>	Shell is a feature tool that hollows out a part, leaving open the selected faces and thin walls on the remaining faces. A hollow part is created when no faces are selected to be open.
<b>sketch</b>	A 2D sketch is a collection of lines and other 2D objects on a plane or face that forms the basis for a feature such as a base or a boss. A 3D sketch is non-planar and can be used to guide a sweep or loft, for example.
<b>SmartMates</b>	A SmartMate is an assembly mating relation that is created automatically.
<b>sub-assembly</b>	A sub-assembly is an assembly document that is part of a larger assembly. For example, the steering mechanism of a car is a sub-assembly of the car.
<b>surface</b>	A surface is a zero-thickness planar or 3D entity with edge boundaries. Surfaces are often used to create solid features. Reference surfaces can be used to modify solid features.
<b>under defined</b>	A sketch is under defined when there are not enough dimensions and relations to prevent entities from moving or changing size.

